

C&I ESS Installation Guide

HYX-EF261P2-EU

-General Version

Delivery and Service Center

V1.0 – 2026/04



| CONTENTS

• **01**
Overview

• **02**
Installation

• **03**
Configuration

• **04**
Commissioning

Product Overview - Topology

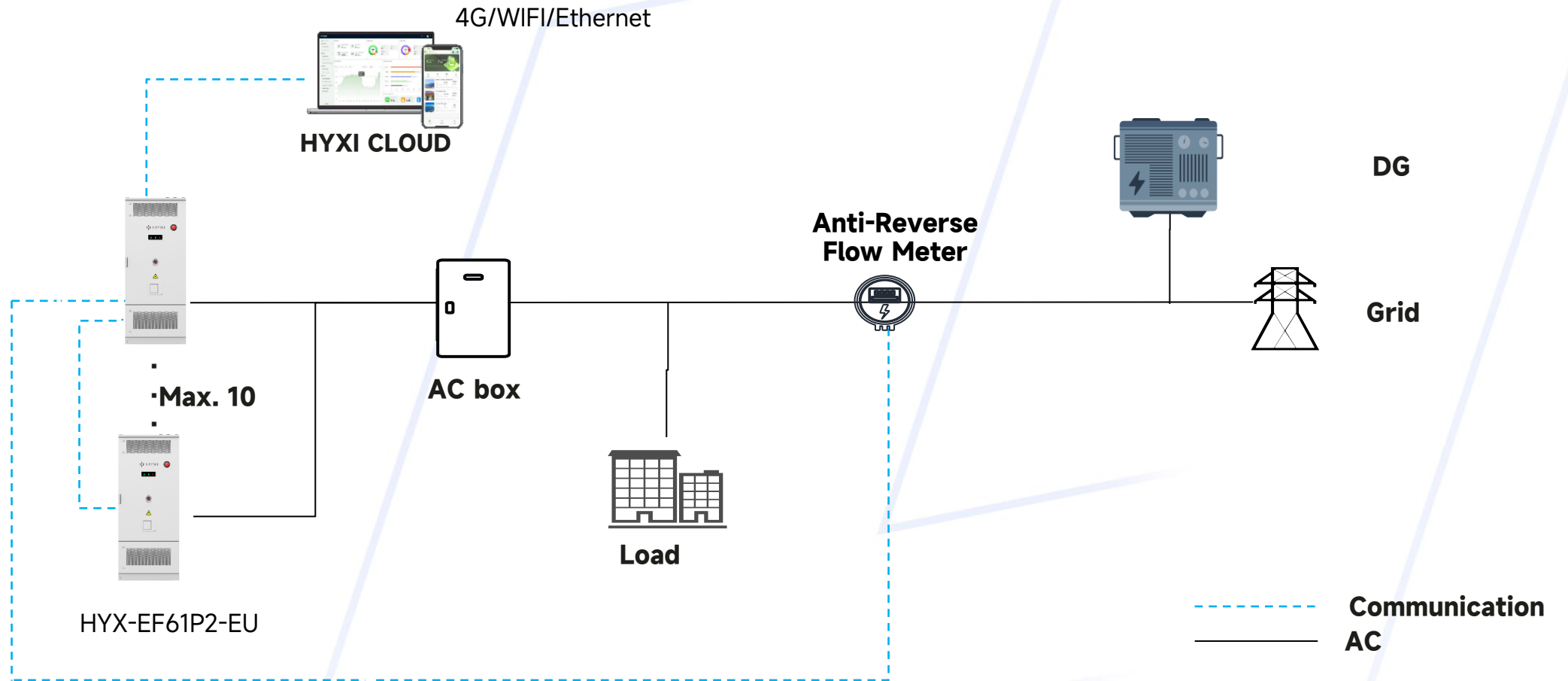

Location recommendations

Site Selection Recommendations

- Safety distance between ESS and production buildings must comply with local fire safety regulations
- Installation environment: good ventilation, free from explosion risks, avoid low-lying areas.
- Indoor installations are prohibited.
- Distance from boundaries, public roads, buildings, flammable materials, hazardous substances, high stacks, and other dangerous objects unrelated to power grid infrastructure >4 meters
- Distance between the top of ESS to combustible materials ≥ 3 meters.
- Distance between ESS to residential buildings 12 meters-Distance between ESS to schools or hospitals >30.5 meters.
- If failure to meet these distances, it's necessary to build fire walls. The distance between ESS and production buildings may reduce to 1 meter when one of the following conditions is met, while considering spatial requirements for equipment transportation, installation, and maintenance:
 - ESS is equipped with a 1-hour fire-resistant independent firewall. Firewall length and height extending 1.5 meters beyond the system's exterior contour.
 - Non-combustible exterior walls must be installed near ESS without openings or combustible finishes, and the exterior walls must meet ASTM E119 or UL 263 standards for 2-hour fire resistance ratings.
- Site must have convenient transportation conditions and be equipped with reliable fire suppression system equipment.
- Distance from the coast >2km.
- If used ≤ 2 km, please confirm with distributors or our company's engineers.

Foundation Recommendations

-Must meet the installation dimensions and load-bearing requirements of the ESS-Foundation surface must comply with anti-leakage requirements-Foundation must be higher than the historical highest water level-Cement base should be embedded 100mm underground. 300mm aboveground level-Horizontal error of contact surface between foundation and ESS <3 mm.

Additional Recommendations

- ESS site should be isolated and protected using solid walls or fences equipped with door locks, height >2.2 meters). Subject to comprehensive design considerations, firewalls may partially or fully replace walls.
- Please use insulation grade and protective construction tools.
- Lightning protection measures are mandatory during installation and commissioning phases.
- All construction personnel must possess qualifications compliant with local regulatory standards

*Site selection recommendations should refer to NFPA 855 Standard for the Installation of Stationary Energy Storage Systems GB 51048 Code for Design of Electrochemical Energy Storage Power Stations, as well as local regulatory requirements. These recommendations are for reference only; actual decisions should be based on local conditions.

Preparation-Foundations

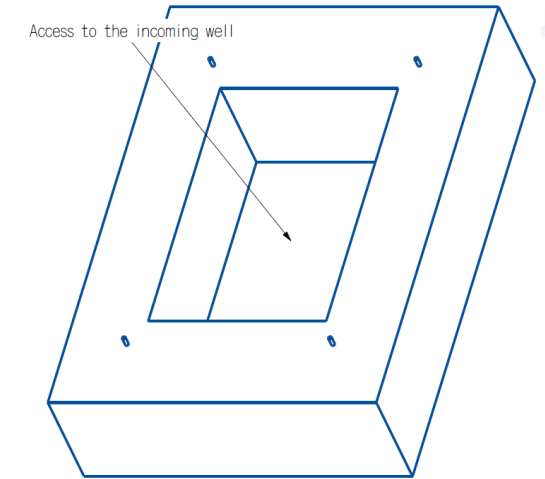
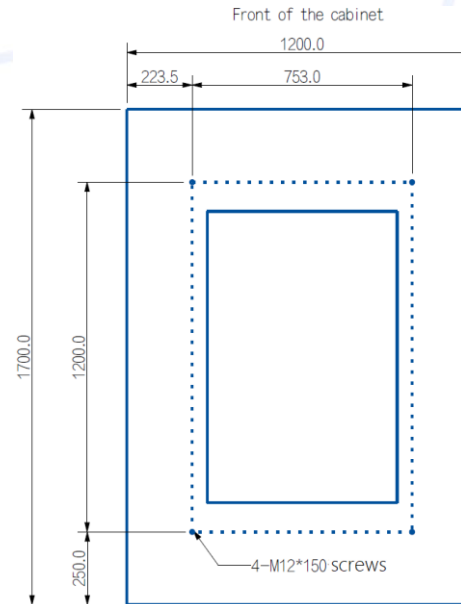
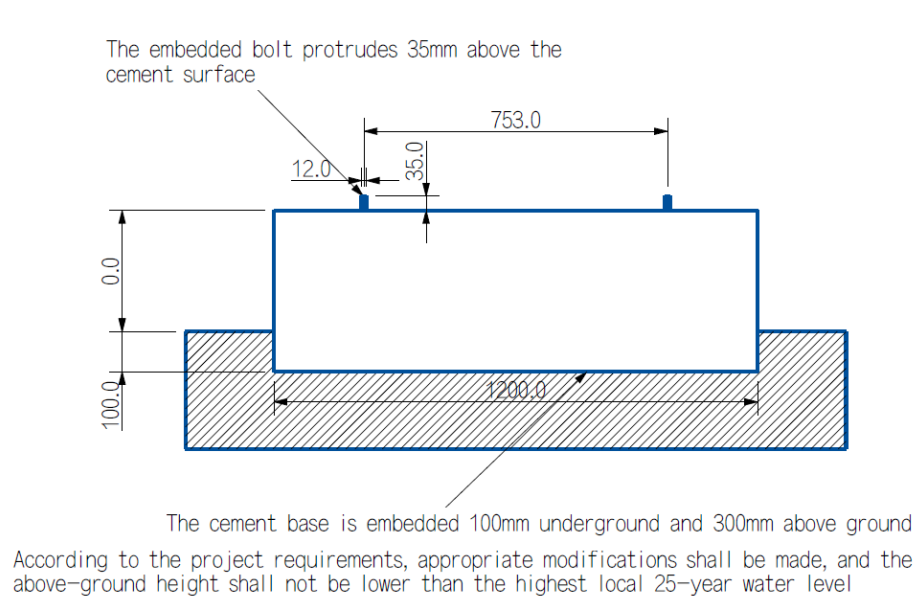

Foundation Description:

1. Concrete shall be of grade C30, and reinforcement shall be HRB400. The concrete cover thickness shall be 40 mm.
2. The bearing stratum for the isolated foundation shall have a characteristic bearing capacity not less than 100 kPa. The foundation base shall rest on undisturbed soil. If loose fill is encountered, it shall be excavated and replaced with a 3:7 lime-soil mixture, with a replacement thickness not less than 500 mm and a compaction coefficient not less than 0.94. The top elevation of the lime-soil cushion shall be measured from the bottom of the plain concrete blinding layer beneath the foundation. A 100 mm thick C15 plain concrete blinding layer shall be provided beneath the foundation, extending 100 mm beyond each side of the foundation. The anchorage length of foundation reinforcement shall be 35 times the diameter of the rebar (35d). Lightning protection grounding shall be embedded at foundation corners; grounding lengths shall be detailed in the electrical drawings.
3. Upon completion of foundation concrete pouring and underground concrete works, backfilling of the foundation pit shall be carried out promptly. Prior to backfilling, accumulated water, loose soil, and construction debris shall be removed. Backfilling shall be done with plain soil, compacted in layers not exceeding 300 mm in thickness, symmetrically, with each layer achieving a compaction coefficient greater than 0.94.
4. Before commencing foundation construction, coordination with all relevant service drawings (e.g. for conduits and pipelines) shall be performed. Construction shall proceed only after verifying consistency with the se drawings.
5. For any matters not covered in these drawings, construction shall comply with the current national and regional codes, standards, and design manuals.

Product Overview – Packing List

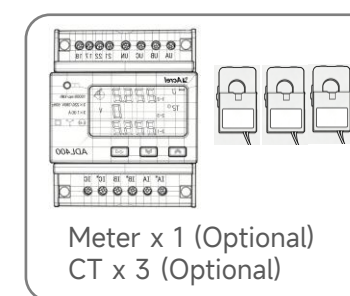
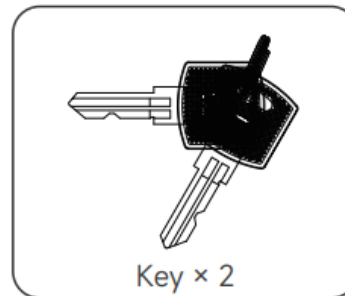
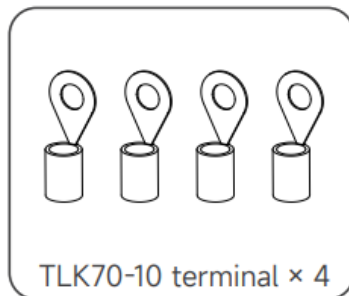
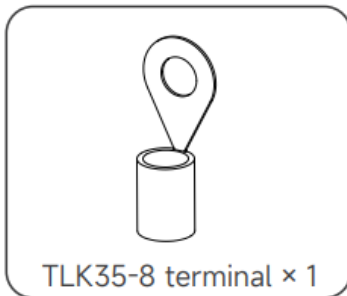
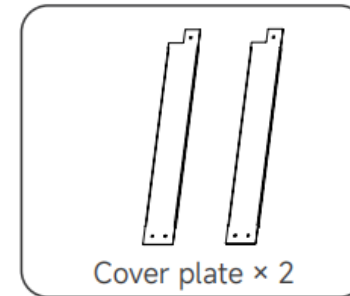
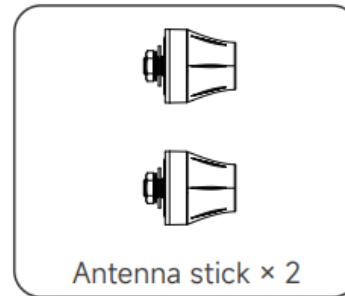
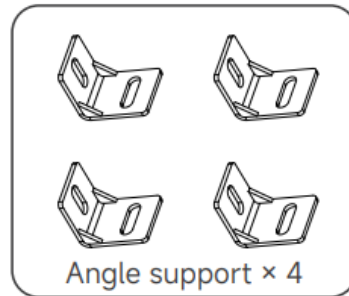
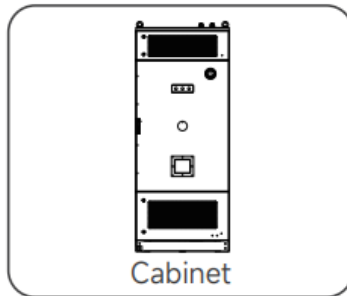

Preparation-Tools

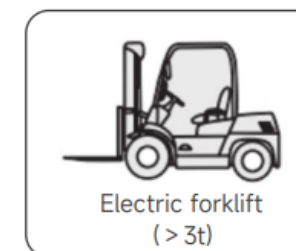
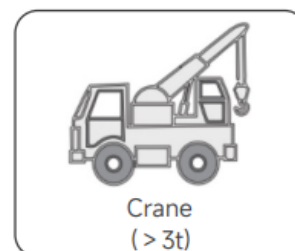
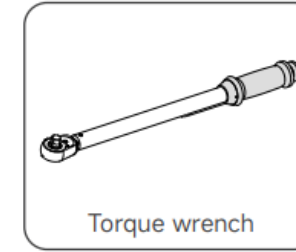
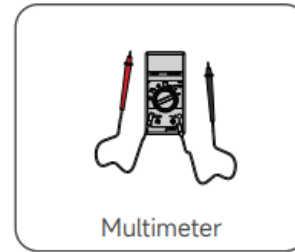
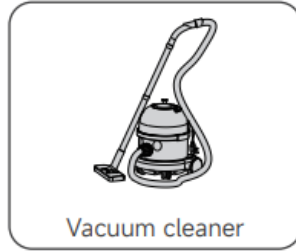
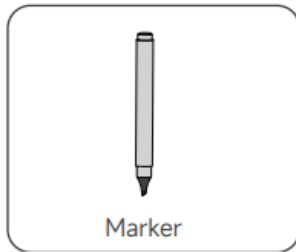
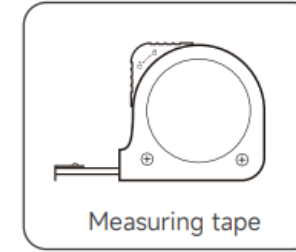
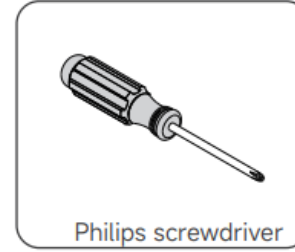
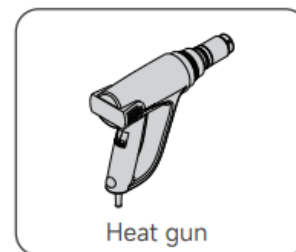
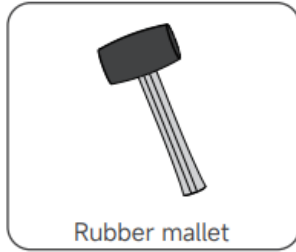
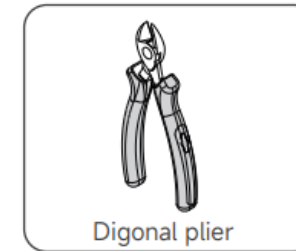
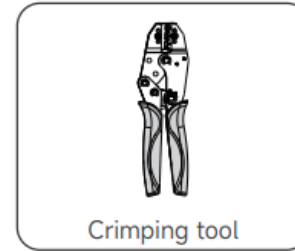
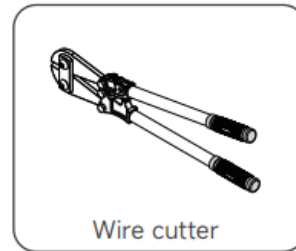
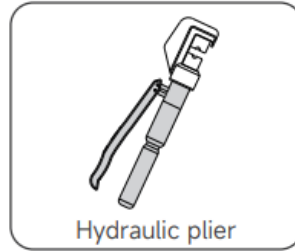
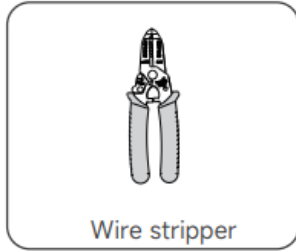

Preparation - Materials



AC side cable
70 mm²



Meter power cable
1.5 mm²



RS485 cable
2*1.0mm²



Ethernet cable



AC breaker
250A

Product Overview - Front

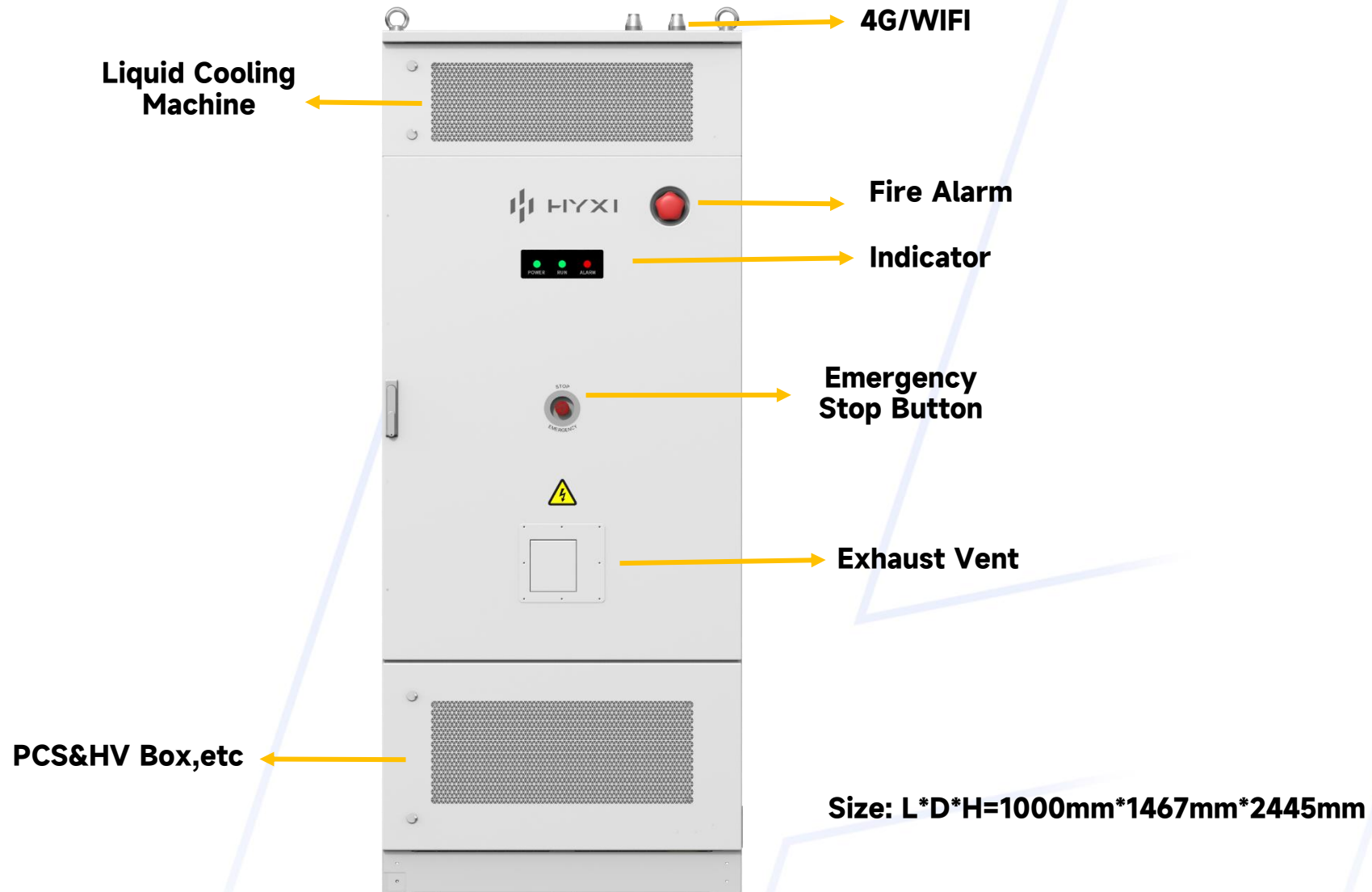

Product Overview - Back

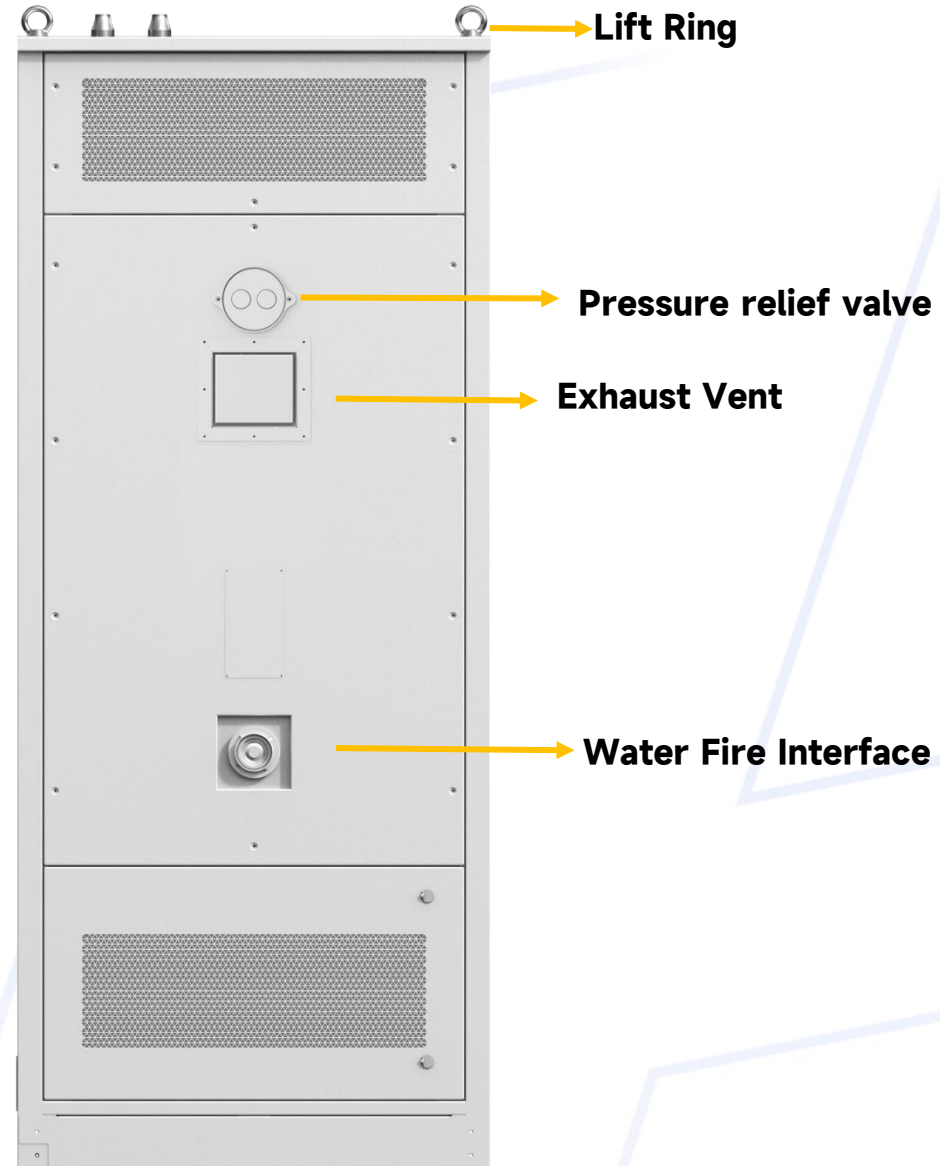

Product Overview - Inside components

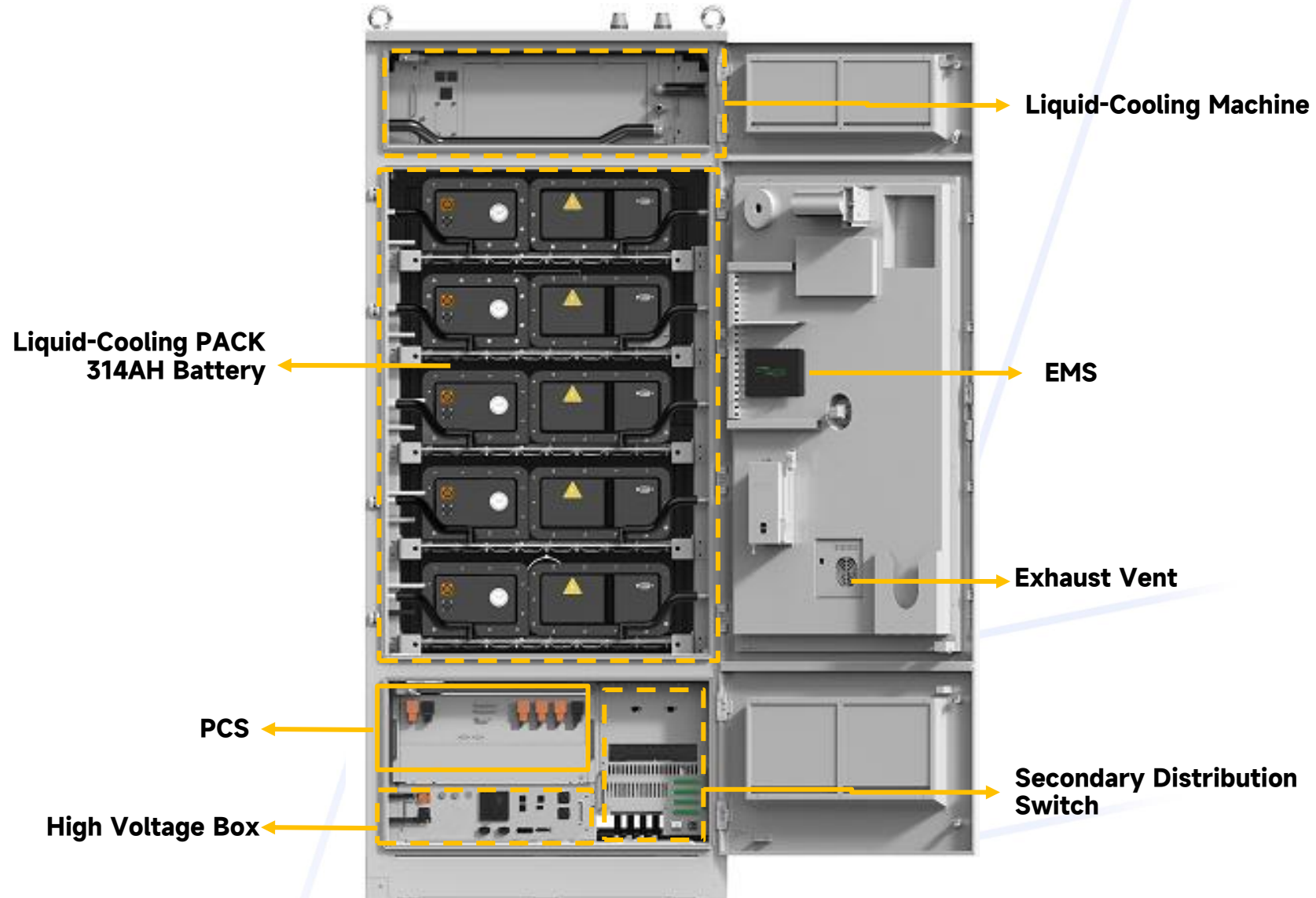

| CONTENTS

• 01
Overview

• 02
Installation

• 03
Configuration

• 04
Commissioning

Equipment Installation-Forklift & Lifting

1. Forklift precautions:
 - a) Use a 5T forklift and keep a safe distance during transportation.
 - b) It is necessary to add protection to the forklift wall to prevent dirt from contaminating the forklift wall or the forklift from scratching the cabinet bottom.
2. Lifting precautions:
 - a) No one is allowed to stand under the boom, and make fine adjustments after the lifting height is lowered.
 - b) Confirm the lifting position and placement direction to see if they are neat and consistent.
3. Each cabinet foot is fixed with M12 bolts, and the tightening torque is set to 55~100N.M.

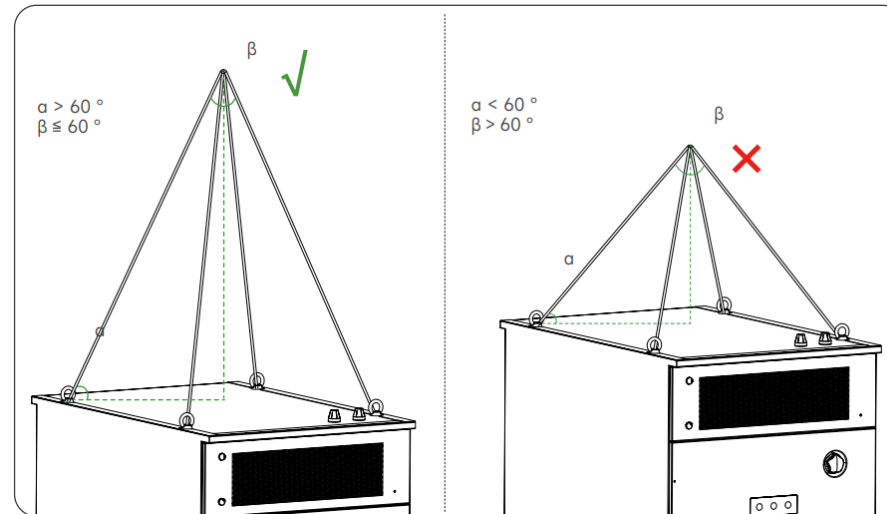

Equipment Installation-Open the Cabinet for Inspection

- Check if the wiring harness is clean and tidy;
- Check if the interfaces of each terminal and the screw fixing ports are loose;
- Check for any obvious damage or missing equipment inside the cabinet;
- Whether the auxiliary materials and accessories are complete;
- Confirm that all circuit breakers inside the cabinet are in the disconnected state.



Grid breaker

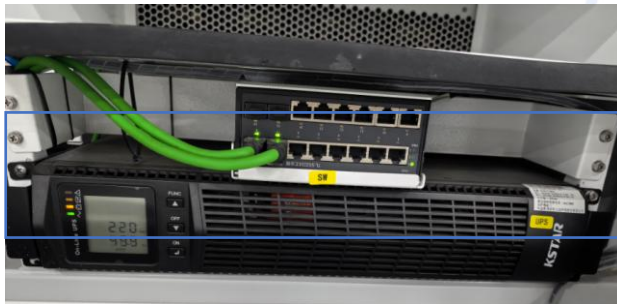

UPS



Cabinet power supply breakers

Equipment Installation-Ground Cable Wiring



1. Power grounding wire
2. Cabinet grounding wire
3. Grounding requirements:
 - a) Drive the grounding angle iron 3 meters into the ground.
 - b) The recommended diameter of the grounding wire harness should be no less than 50 mm^2 (copper conductor) or meet local regulations.
 - c) The grounding resistance value must be $\leq 4\Omega$.

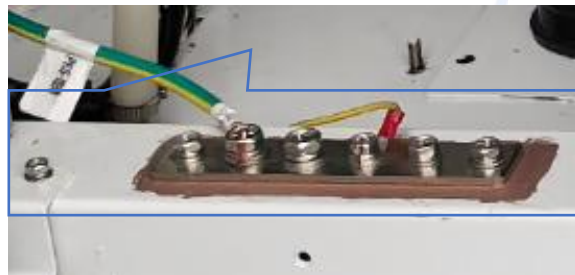

Equipment Installation-Grid Cables



Uu Uv Uw N
From grid side

- Confirm the power-off status:
 - a) The grid-side circuit breaker connected to the upper level of the energy storage cabinet is in the disconnected state;
 - b) All circuit breakers inside the cabinet are in the disconnected state.
- According to the diagram, confirm the order of the live wire and the neutral wire.
- The wire harness is introduced through the wire entry hole at the bottom of the equipment and led to the connection point through the wire trough. It is recommended to use a cable specification of ZC- YJV22-0.6/1KV-70mm² (the wire diameter can be appropriately increased according to the on-site environment).
- After the wiring construction is completed and passed the inspection, use protective mud to seal the wire entry hole.

Equipment Installation - Meter installation

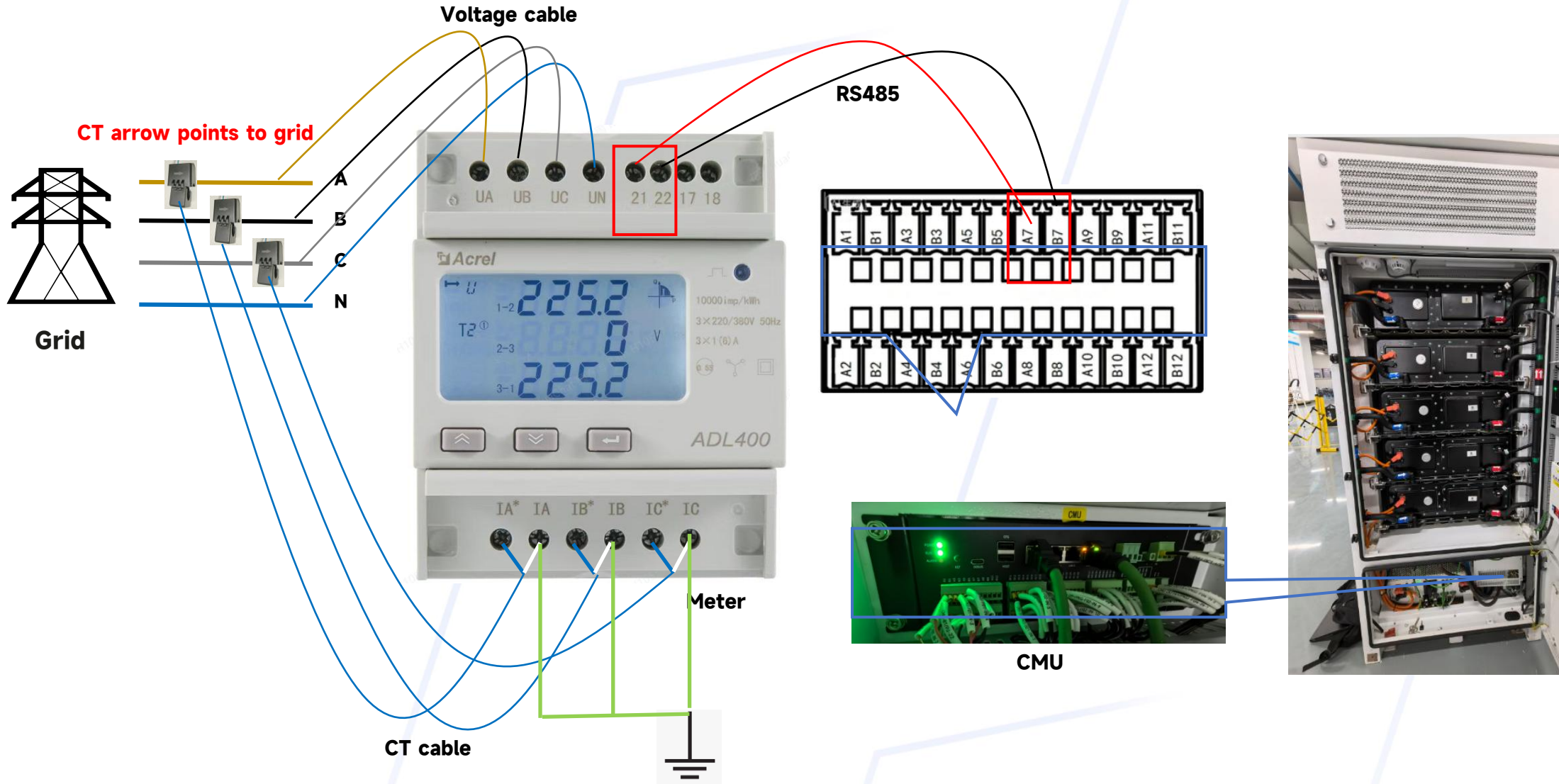

Parallel Connection Installation (Optional)

AC Cable connection

All cabinets connect to AC box, then to grid.

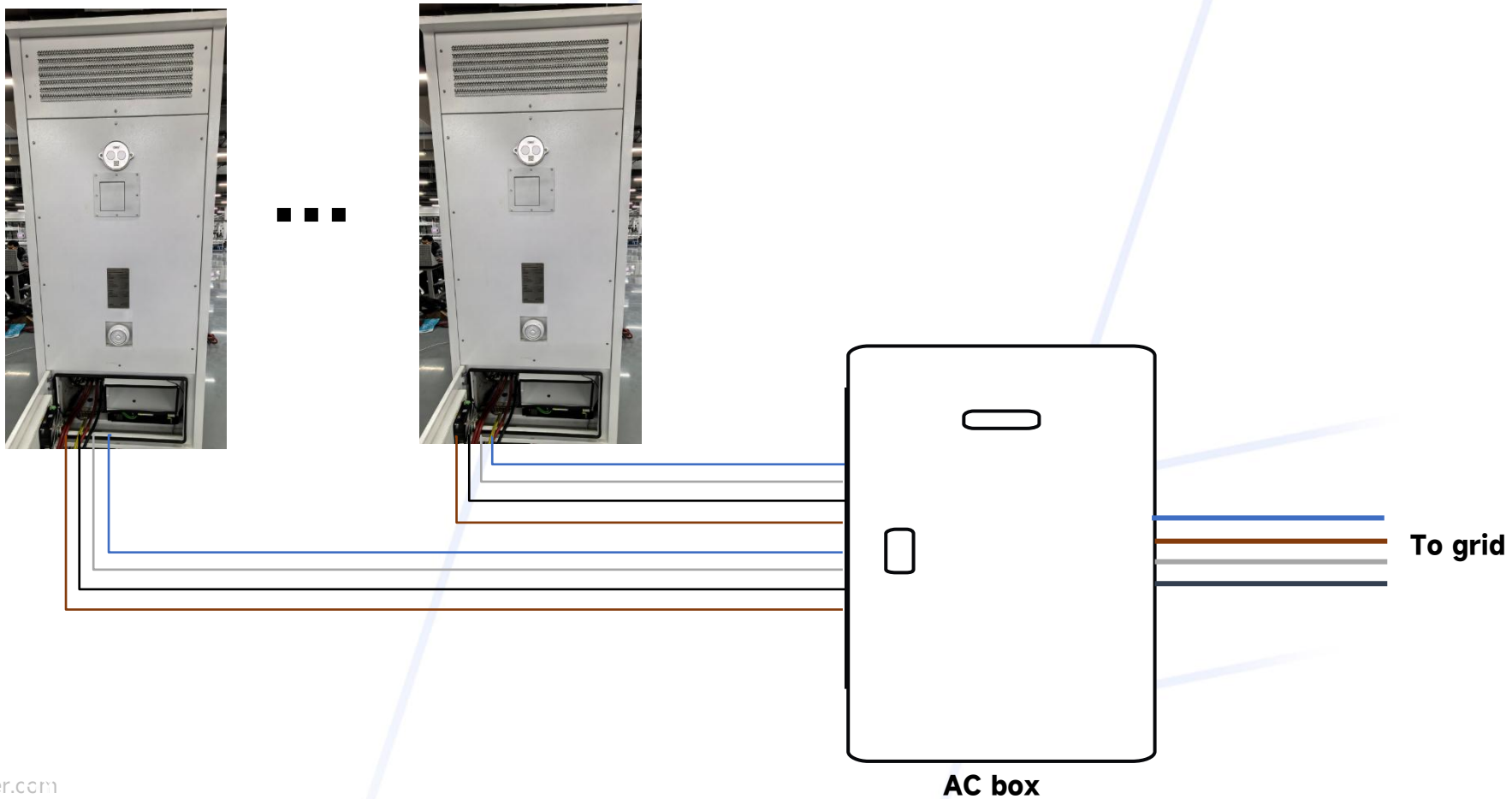

Parallel Connection Installation (Optional)

Communication Cable connection

All slaves cabinets connect to Master cabinet switch box.

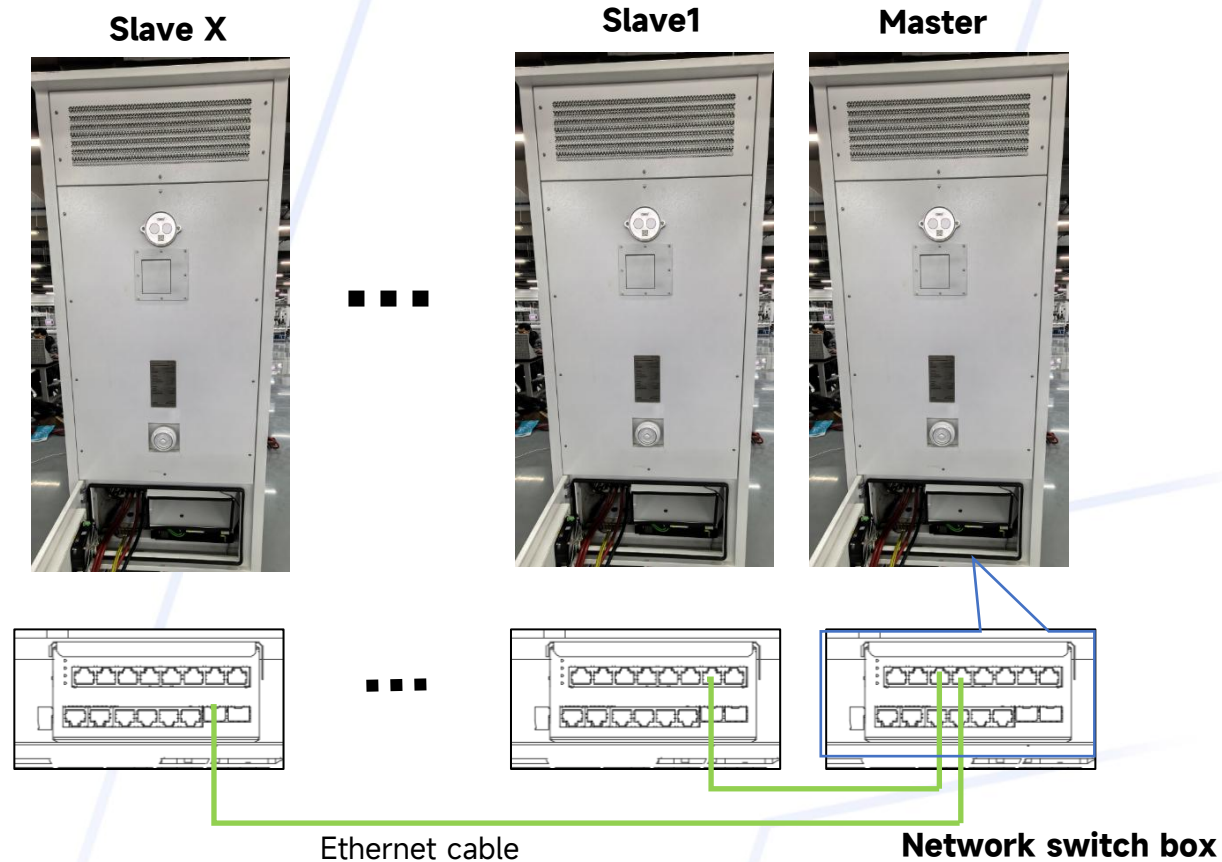

| CONTENTS

• 01
Overview

• 02
Installation

• 03
Configuration

• 04
Commissioning

System Operation-Power On

Power on

Network setting

Operator Account

Add CMU

Add anti-flow meter

Change PCS IP

Set running strategy

create plant



Before System Power on:
Check the voltages on the QF1 breaker which is from grid side.
Make sure that all voltages are normal.

- A-B;A-C;B-C
- A-N;B-N;C-N
- A-G;B-G;C-G;N-G



System Operation-Power On

Power on

Network
setting

Operator
Account

Add CMU

Add anti-flow
meter

Change PCS IP

Set running
strategy

create plant



- Press the ON button for more than 3 seconds, wait for the screen to light up.
- Press FUNC Make sure that the UPS have voltage output.



System Operation-Power On

Power on

Network
setting

Operator
Account

Add CMU

Add anti-flow
meter

Change PCS IP

Set running
strategy

create plant



QF1



QF11~QF17



- Turn on QF1 breaker;
- Turn on the all the control breakers.
QF11: Liquid cooling machine;
QF12: UPS;
QF13: Lights;
QF14: Power Supply 1 ;
QF15: High voltage box of battery;
QF16: Power Supply 2;
QF17:Fans and fire system;

Confirm that the corresponding equipment has been powered.

System Operation-Power On

Power on

Network
setting

Operator
Account

Add CMU

Add anti-flow
meter

Change PCS IP

Set running
strategy

create plant



- Turn on the breaker on the high voltage box.
- Press the power button to power up the box.

System Operation - Network Setting

Power on

Network setting

Operator Account

Add CMU

Add anti-flow meter

Change PCS IP

Set running strategy

create plant

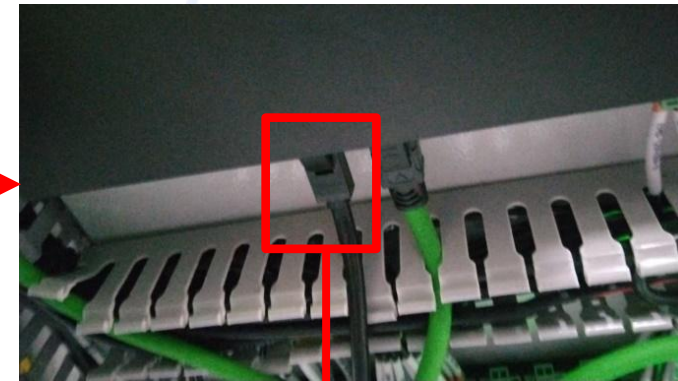

- Use a regular network cable, plug one end into the computer and the other end into the EMS interface.

System Operation - Network setting



- In order to establish communication with EMS, we need to set our computers to a unified network segment. You can set the computer IP to 192.168.101.100

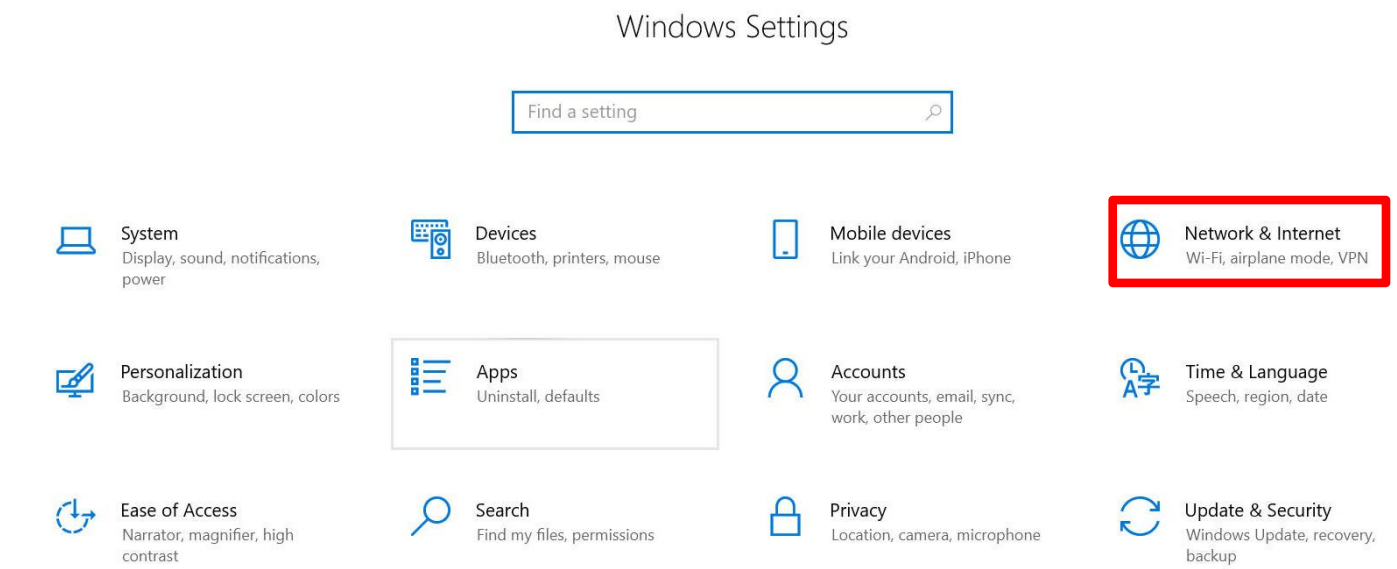
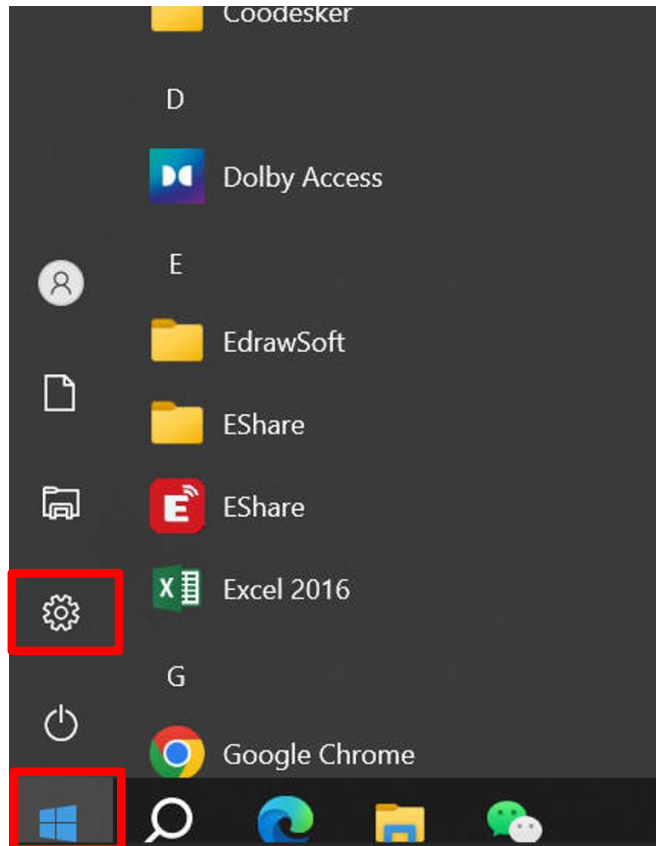

System Operation - Network setting

Power on

Network setting

Operator Account

Add CMU

Add anti-flow meter

Change PCS IP

Set running strategy

create plant

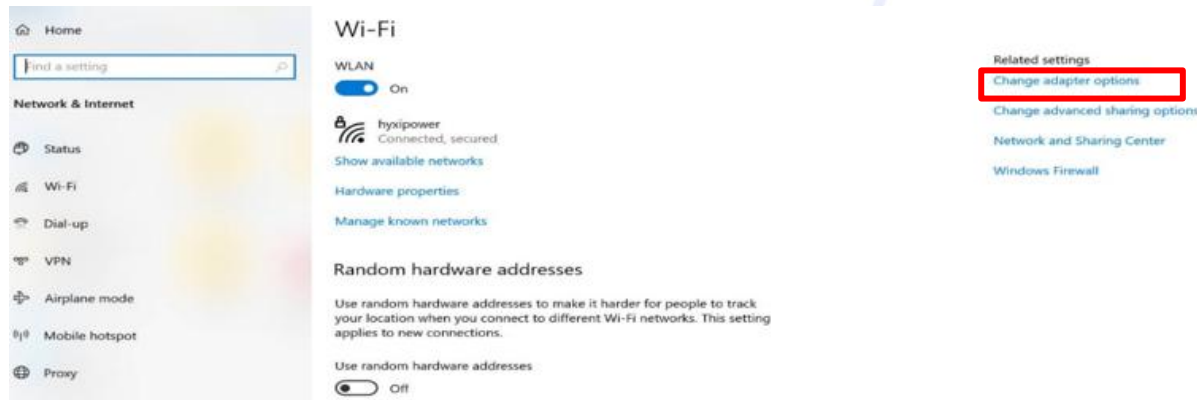

➤ Select : Change adapter option



➤ Select the icon that the computer is currently connected to

System Operation - Network setting

Power on

Network setting

Operator Account

Add CMU

Add anti-flow meter

Change PCS IP

Set running strategy

create plant

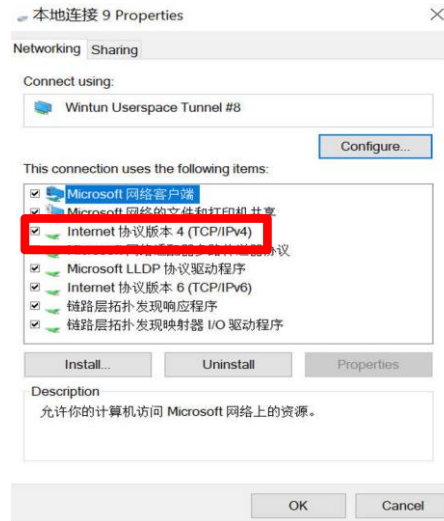

➤ Select : TCP/IPv4

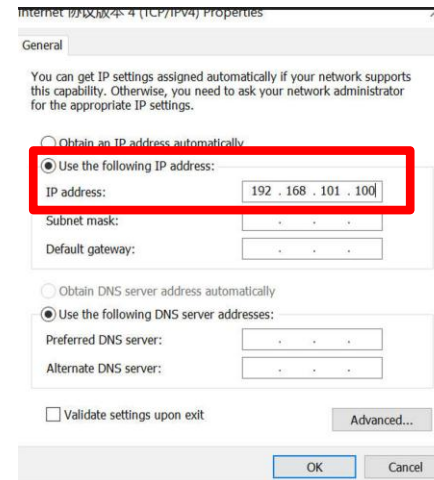

➤ Change the IP address as : 192.168.101.100

System Operation - Network setting

Power on

Network setting

Operator Account

Add CMU

Add anti-flow meter

Change PCS IP

Set running strategy

create plant

- Network Settings – Network Setting - WLAN
- Choose corresponding WIFI signal
- Enter account and password
- Connection successful.

The screenshot displays the HYXiPOWER web interface. At the top, there is a navigation bar with 'Language Conversion', 'Home', and the date '2026/03/17 08:57'. Below this, the 'Account System' section is active, with a sub-menu containing 'Personal Information', 'Account Management', 'System (Site) configuration', and 'Network Setting' (highlighted with a red box). Under 'Network Setting', the 'WLAN' tab is selected (highlighted with a red box). The main content area shows 'WIFI currently in use: None' and a 'Search for nearby WIFI' button. A list of detected WiFi networks is displayed:

Network Name	Signal Strength
TP-LINK_2841	signal: 61/70
WIFI-15BB	signal: 31/70
FST	signal: 28/70
TP-LINK_20FB	signal: 37/70
HUAWEI-1CRXH3	signal: 24/70
@Ruijie-sBA06_iot	signal: 22/70

The 'TP-LINK_20FB' network is selected, and a 'Please enter password' input field (highlighted with a red box) and a 'Connect' button are visible.

System Operation - Add Operator Account



- Enter 192.168.101.1:8888 in the browser.

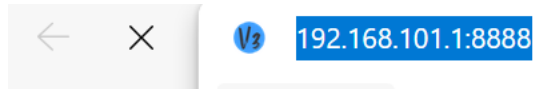

- For Hyxipower engineer, the default account and password:
Account: admin
Password: admin123
- Set up an operator account for the distributor:
Account information - Account Management - Account Management - Add.

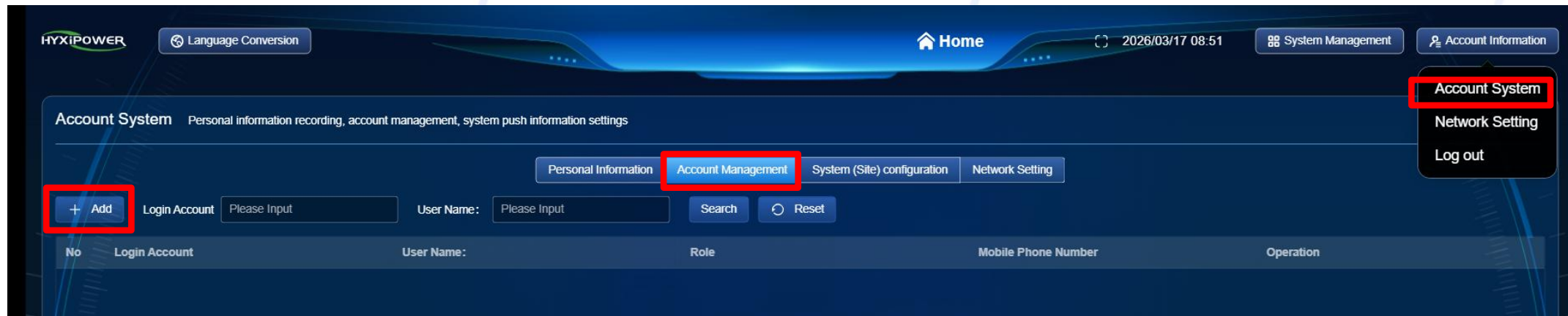

System Operation - Add CMU

Power on

Network setting

Operator Account

Add CMU

Add anti-flow meter

Change PCS IP

Set running strategy

create plant

- Normally CMU is already add in EMS. If there is no CMU is the device list, or if there are more than one cabinet, engineer need to add it manually.

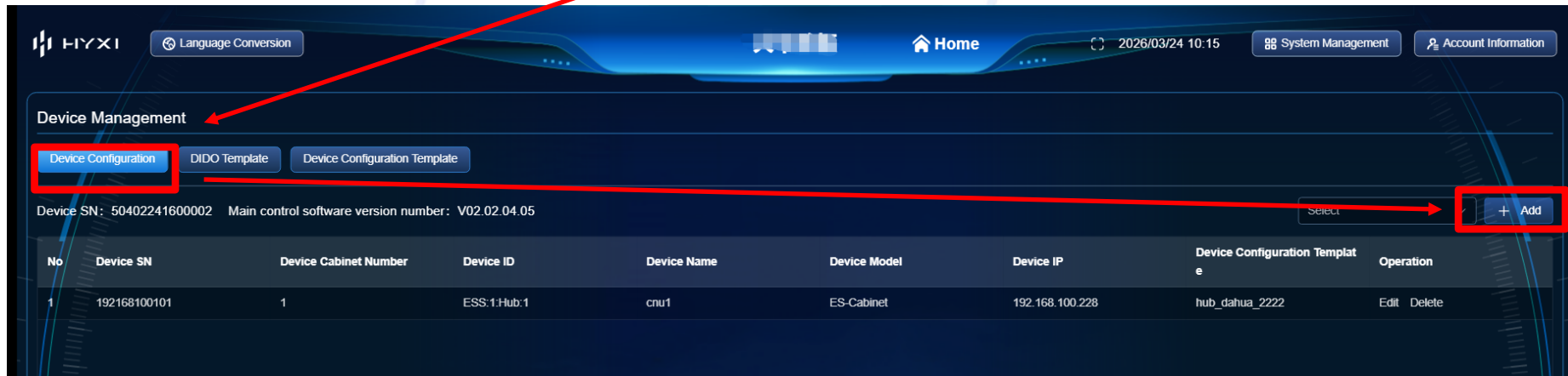

System Operation - Add CMU



Edit

* Device SN	192168100101
* Device Name	cmu1
* Device Model	ES-Cabinet
* Device IP	192.168.100.228
* Device Cabinet Number	1
* Device ID	ESS:1:Hub:1
* Device Configuration Template	261

Cancel Confirm

CMU SN. It is detected automatically by EMS. Choose the one you want to add.

Name the CMU.

CMU model is ES-Cabinet.

CMU IP address. It is default.

Name the cabinet number.

Default

Ask Hyxi engineer for the CMU template.

System Operation - Add anti-flow meter

Power on

Network setting

Operator Account

Add CMU

Add anti-flow meter

Change PCS IP

Set running strategy

create plant

Device Management

Device Configuration | DIDO Template | **Device Configuration Template**

+ Add Select

No	Template Name	Operation
1	261	Edit Delete
2	522_slave	Edit Delete

Device Management

Device Configuration | DIDO Template | **Device Configuration Template**

< Template Name: 261

LAN Port **RS485** CAN DIDO Virtual Device hubCfg

+ Add

Communication Port: rs485_7

Baud Rate: 9600

Data Bits: 8

Stop Bits: 1

Parity Bit: N

Communication Protocol: modbus

Cancel Confirm

No	Communication Port	Baud Rate	Data Bits	Stop Bits	Parity Bit	Communication Protocol	Operation
1	rs485_1	9600	8			modbus	Device Configuration Edit Delete
2	rs485_2	9600	8			modbus	Device Configuration Edit Delete
3	rs485_3	9600	8			modbus	Device Configuration Edit Delete
4	rs485_4	19200	8	1	N	modbus	Device Configuration Edit Delete
5	rs485_5	9600	8	1	N	modbus	Device Configuration Edit Delete

System Operation - Add anti-flow meter



Device Management

Device Configuration | DIDO Template

Template Name: 261

LAN Port: RS485 | CAN | DIDO

+ Add

No	Communication Port
1	rs485_1
2	rs485_2
3	rs485_3
4	rs485_4
5	rs485_5
6	rs485_6
7	rs485_7
8	rs485_8

Edit Device

* Device Name: Anti flow meter

* Device ID: 1

* Device Type: Meter

* Device Model: Acrel-ADL400

Unique Properties

CT	60	CT ratio
PT	1	
funcType	ESS	
interval	20	
slave	1	
timeout	1000	

Cancel | Confirm

Device Configuration

No	Device Name	Device ID	Device Type	Device Model	Operation
1	Anti flow meter	2	Ammeter	D70000-V1B41	Edit Delete

Stop Bits	Parity Bit	Communication Protocol	Operation
1	N	modbus	Device Configuration Edit Delete
1	N	modbus	Device Configuration Edit Delete
2	N	modbus	Device Configuration Edit Delete
1	N	modbus	Device Configuration Edit Delete
1	N	modbus	Device Configuration Edit Delete
1	N	modbus	Device Configuration Edit Delete
1	N	modbus	Device Configuration Edit Delete
1	N	modbus	Device Configuration Edit Delete

Save

System Operation - Change PCS IP address

Power on

Network setting

Operator Account

Add CMU

Add anti-flow meter

Change PCS IP

Set running strategy

create plant

- If there are multi PCS installed, The PCS IP address need to be re-distributed
- PCS 1: 192.168.100.118
- PCS 2: 192.168.100.120
- PCS 2: 192.168.100.122
- PCS 2: 192.168.100.124
- ...

Device Management

Device Configuration | DIDO Template | Device Configuration Template

Template Name: 261

LAN Port | RS485 | CAN | DIDO | Virtual Device | hubCfg

+ Add

No	Device IP	Communication	Operation
1	192.168.100.118	502	Device Configuration Edit Delete

Edit Port

* Device IP: 192.168.100.118

* Protocol Type: modbus

* Port: 502

Cancel | Confirm

Save

System Operation - Change PCS IP address

Power on

Network
setting

Operator
Account

Add CMU

Add anti-flow
meter

Change PCS IP

Set running
strategy

create plant

- Use a regular network cable, plug one end into the computer and the other end into the PCS interface.
- Change the computer IP address to 192.168.100.100. Please refer to <Network setting>

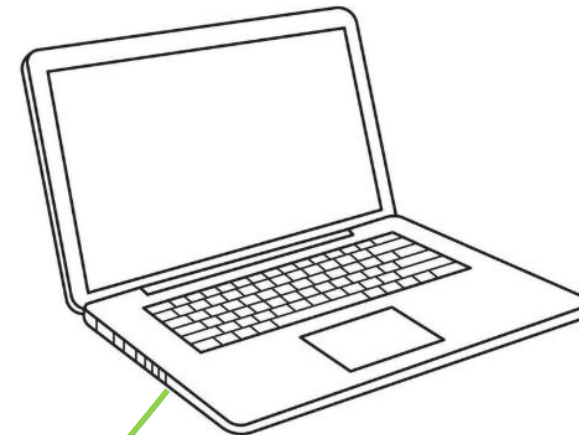
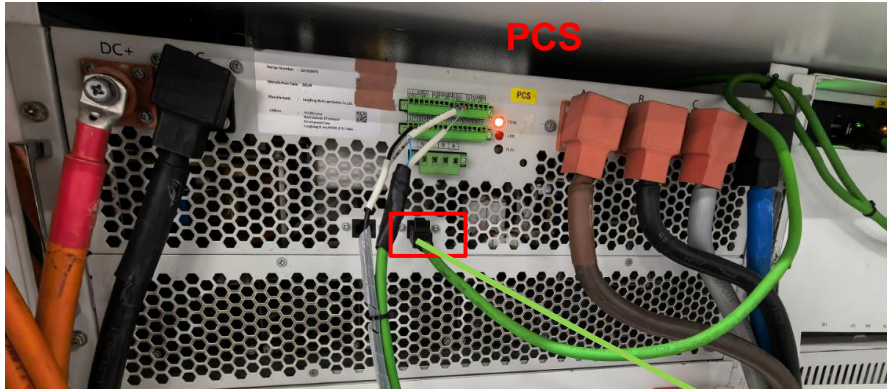

System Operation - Change PCS IP address



- Open the pcs.exe software and log in with the admin account. Password 2200.
- Log in the parameter setting interface.

Language: English

User: Admin

Password: 2200 Show password

Network: 192.168.100.118

Serial port

Refresh

PCS: INPPCS-125kW-OS

Login

Admin | INPPCS-125kW-OS | Connect

Grid side voltage of PhA(V)	Port voltage of PhA(V)	AC Q of PhA(kVar)
Grid side voltage of PhB(V)	Port voltage of PhB(V)	AC Q of PhB(kVar)
Grid side voltage of PhC(V)	Port voltage of PhC(V)	AC Q of PhC(kVar)
Branch1 current of PhA(A)	Branch2 current of PhA(A)	AC P of PhA(kW)
Branch1 current of PhB(A)	Branch2 current of PhB(A)	AC P of PhB(kW)
Branch1 current of PhC(A)	Branch2 current of PhC(A)	AC P of PhC(kW)
Branch1 current of PhN(A)	Branch2 current of PhN(A)	Total output P(kW)
Grid side freq(Hz)	Battery voltage(V)	Direct voltage on capacitance(V)
AC charging capacity(kWh)	DC Bus Voltage(V)	Direct voltage under capacitance(V)
AC discharge capacity(kWh)	DC bus current(A)	Total output Q(kVar)
Temperature of PhA(°C)	Temperature of PhB(°C)	Temperature of PhC(°C)
Temperature of PhN(°C)	Temperature of Inlet(°C)	Temperature of Internal(°C)
Temperature of outlet(°C)	Voltage of D-axis(V)	Current of D-axis(A)
Leakage current(A)	Voltage of Q-axis(V)	Current of Q-axis(A)
Filtering capacitor voltage of PhA(V)	DC component of PhA(A)	Voltage of P-pole to ground(V)
Filtering capacitor voltage of PhB(V)	DC component of PhB(A)	Voltage of N-pole to ground(V)
Filtering capacitor voltage of PhC(V)	DC component of PhC(A)	Insulation resistance(kΩ)
BMS working status cmd	Total voltage of battery stack(V)	Single highest SOC(%)
BMS maximum charging current(A)	Total current of battery stack(A)	Single lowest SOC(%)
BMS maximum discharge current(A)	Battery stack SOC(%)	Single highest voltage(V)
BMS maximum charging power(kW)	BMS Work Status	Single lowest voltage(V)
BMS maximum discharge power(kW)		

Start Stop Reset Fault Machine time

Home Power-on Setting Run Info Param Setting Oscilloscope Upgrade 192.168.0.20

System Operation - Change PCS IP address



- Change the COM1 IP0 ~ COM1 IP3. Press <Enter> after you type in the number.
- **Power off** the PCS then restart it to refresh the setting.

Category	Parameter Name	Value	Description	Unit
Sys conf	COM1-IP0	192	PCS-MAC0	EMS site address for PCS
	COM1-IP1	168	PCS-MAC1	485-1(BMS) Baud rate setting
	COM1-IP2	100	PCS-MAC2	485-2(EMS) Baud rate setting
	COM1-IP3	118	PCS-MAC3	CAN-1 Baud rate setting
				CAN-2 Baud rate setting
Prot param			PCS-MAC4	CAN-2 Baud rate setting
			PCS-MAC5	BMS site address for PCS
Safe param	COM2-IP0		Latest index for fault recording	DHCP service settings
	COM2-IP1		Fault waveform reading index	ARM debugging word
	COM2-IP2		Fault recording debugging words 1	Network port application type of COM1
	COM2-IP3		Fault recording debugging words 2	
Col param			Client connection number of COM2	
			Client connection number of COM2	
			Client connection number of COM2	
			Client connection number of COM2	
			Client connection number of COM2	
			Client connection number of COM2	
Comm param	Network card automatic reset count		Fault recording SPI communication debugg...	1st channel of the oscilloscope
	LWIP TCP_PCB used quantity		Fault recording SPI communication debugg...	2nd channel of the oscilloscope
	LWIP PBUF_POLL used quantity			3rd channel of the oscilloscope
	LWIP NETBUF used quantity		Total number of event records	4th channel of the oscilloscope
	LWIP NETCONN used quantity		Earliest index of event records	
	LWIP limited traffic counting		Newest index of event records	
	LWIP traffic limit setting			
	LWIP traffic limit interval time			
Oth er				

System Operation – Set running strategy

Power on

Network setting

Operator Account

Add CMU

Add anti-flow meter

Change PCS IP

Set running strategy

create plant

➤ Set Strategy template

The screenshot displays the 'Strategy Management' interface. On the left, there are three mode selection buttons: 'Manual Mode', 'Automatic Mode' (highlighted with a red box), and 'Platform Dispatch'. The main area shows the 'Strategy Operation' tab with a '+ Add New Strategy' button (highlighted with a red box). Below this, there are input fields for 'Template Name' and 'Strategy Type' (set to 'Peak Shaving and Valley Fill'). Two tabs, 'Basic Parameters' and 'Strategy Parameters', are visible. The 'Strategy Parameters' tab is active, showing a timeline from 00:00 to 24:00. A table below the timeline lists the strategy periods with columns for Start Time, End Time, Energy Storage Control Type, Energy Storage Planned Power, and Actions.

Start Time	End Time	Energy Storage Control Type	Energy Storage Planned Power	Actions
00:00	05:00	Charging	40 kW	Remove
05:00	08:00	Standby	0 kW	Remove
08:00	11:00	Discharging	50 kW	Remove
11:00	13:00	Charging	50 kW	Remove
13:00	13:30	Standby	0 kW	Remove
13:30	18:00	Discharging	50 kW	Remove
18:00	24:00	Standby	0 kW	Remove

At the bottom of the interface, there are 'Save' and 'Delete' buttons (both highlighted with red boxes).

System Operation – Set running strategy

Power on

Network setting

Operator Account

Add CMU

Add anti-flow meter

Change PCS IP

Set running strategy

create plant

➤ Set Strategy template

The screenshot displays the 'Strategy Management' interface. At the top, it shows system status: 'Current Operation Mode: Manual', 'Site Status: Disconnected', and 'Charge/Discharge Status: Standing'. The left sidebar contains three mode options: 'Manual Mode' (Manual control of system startup/shutdown, grid connection/disconnection, etc.), 'Automatic Mode' (Site automatically controlled by predefined strategies), and 'Platform Dispatch' (Platform controls the site through this system). The main content area is titled 'Strategy Management' and has two tabs: 'Strategy Template' and 'Strategy Operation'. A large blue '+' button is visible. Below it, there are input fields for 'Template Name' (Maximum 20 characters) and 'Strategy Type' (set to 'Peak Shaving and Valley Fillin'). Two tabs, 'Basic Parameters' and 'Strategy Parameters', are present. The 'Strategy Parameters' tab is active and contains several configuration fields: 'Maximum Cell Voltage Threshold (2.50~3.65): 3.65 V', 'Minimum Cell Voltage Threshold (2.50~3.65): 2.5 V', 'Temperature Upper Limit (≤45°C): 45 °C', 'SOC Upper Limit: %', and 'SOC Lower Limit: %'. A red box highlights the 'Strategy Parameters' tab and the 'Save' button at the bottom left. A red arrow points from the 'Strategy Parameters' tab to the 'Save' button.

System Operation – Set running strategy



- Create Strategy Operation and add Template in it.

Strategy Management Current Operation Mode: Automatic Current Execution Strategy: Peak Shaving and Valley Filling Site Status: Connected Charge/Discharge Status: Discharging

Mode Management

- Manual Mode**
Manual control of system startup/shutdown, grid connection/disconnection, etc.
- Automatic Mode**
Site automatically controlled by predefined strategies

Strategy Template **Strategy Operation**

Strategy Preview

+

* Strategy Name: Demo

* Execution Cycle: Long-term

* Priority: 1

* Strategy Template:

Power grid control parameter settings Save Delete

Launch

Setting

Anti-backflow Parameters Demand Control Parameters

Anti-Reverse Flow: LV Side Enabled

* Anti-backflow Threshold: 0 kW

Active Anti-backflow Enable:

Phase separation control enables:

Cancel Confirm

System Operation - Create Plant on APP



- Download HYXI APP in Apple store or Google play store
- Register Now - Register as Organization.

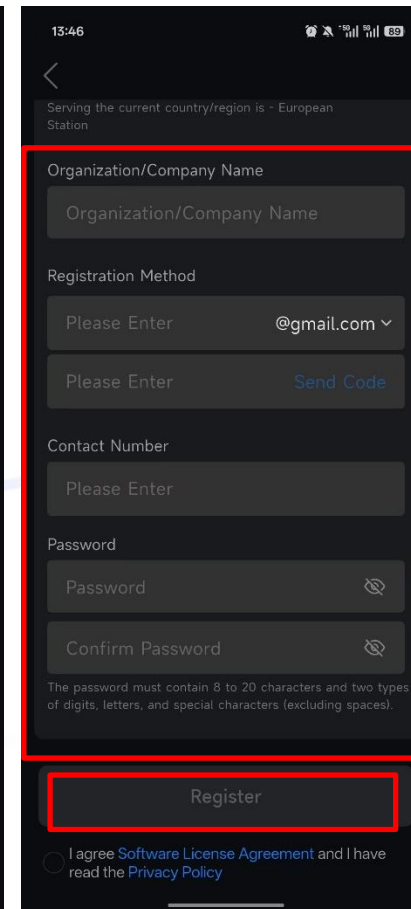
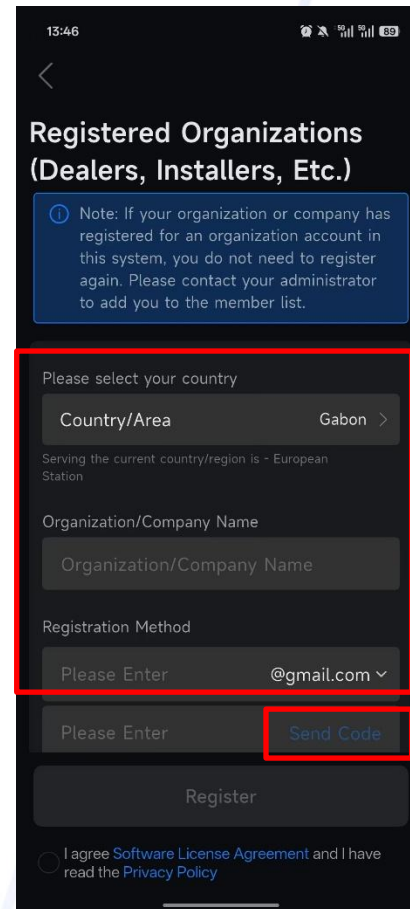
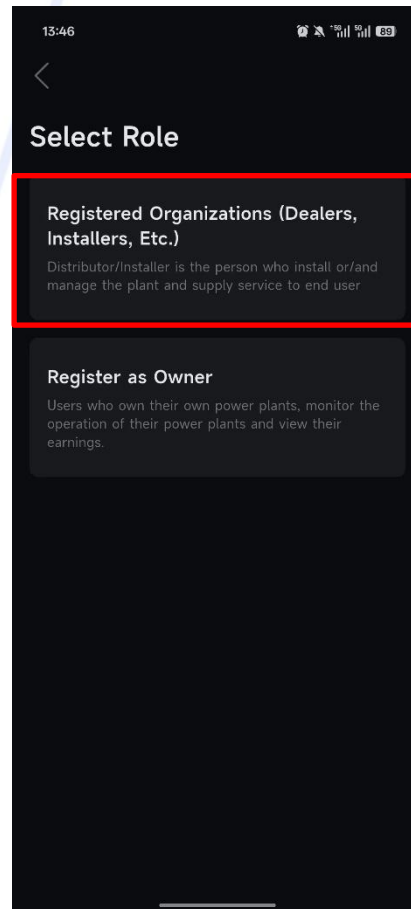
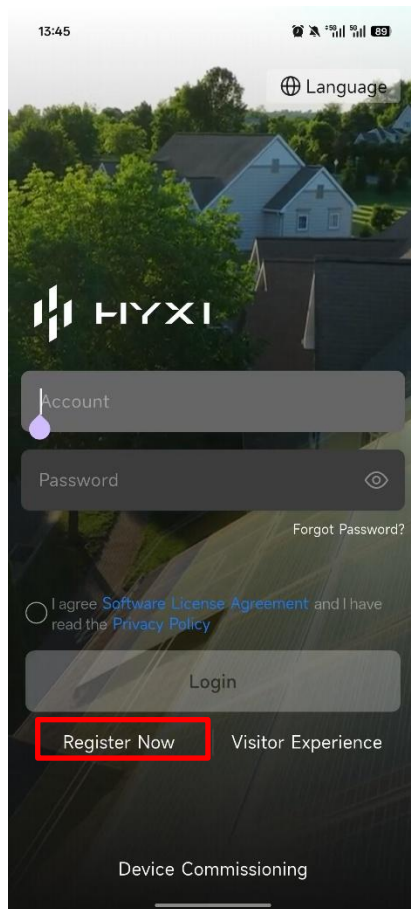

System Operation - Create Plant on APP



➤ Log in your organization account and Add Plant

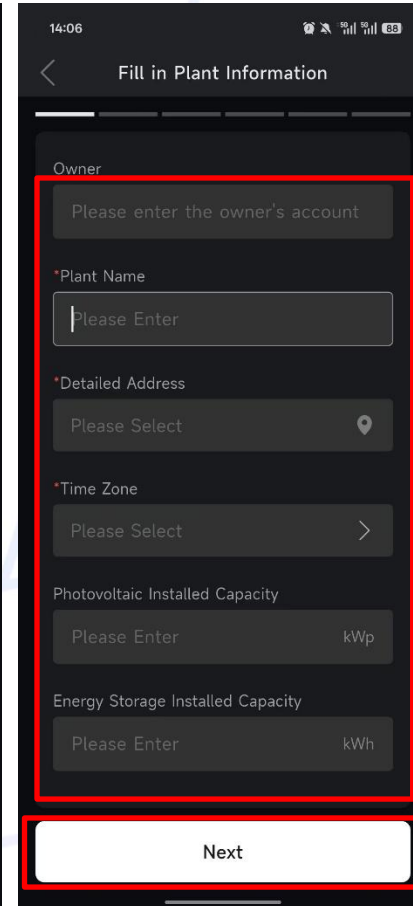
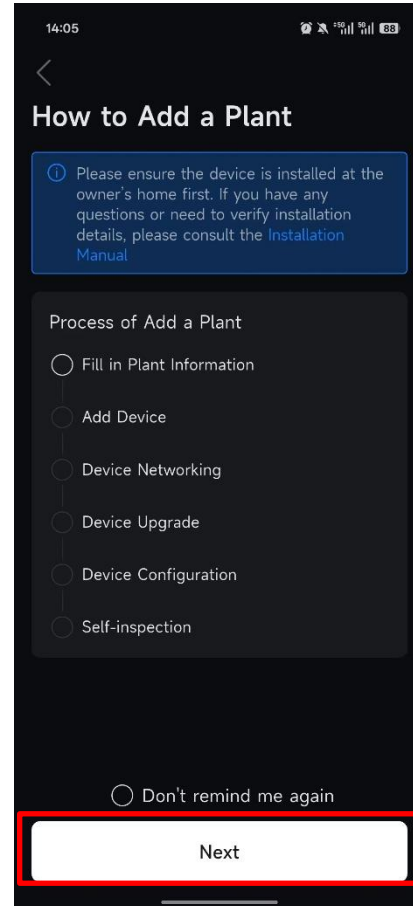
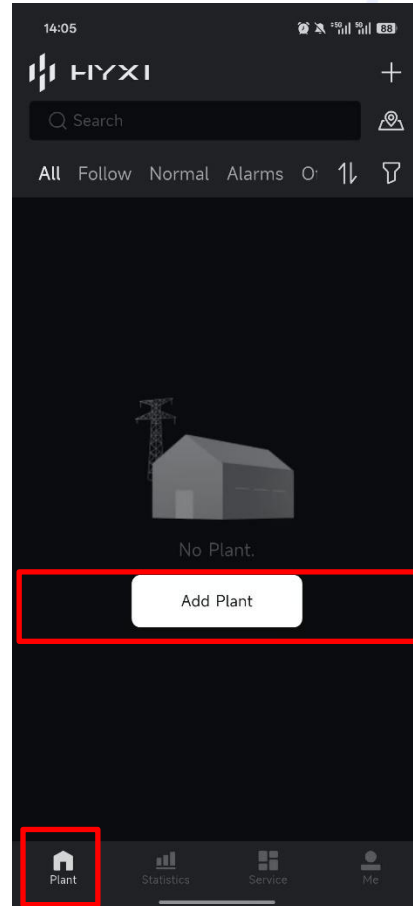
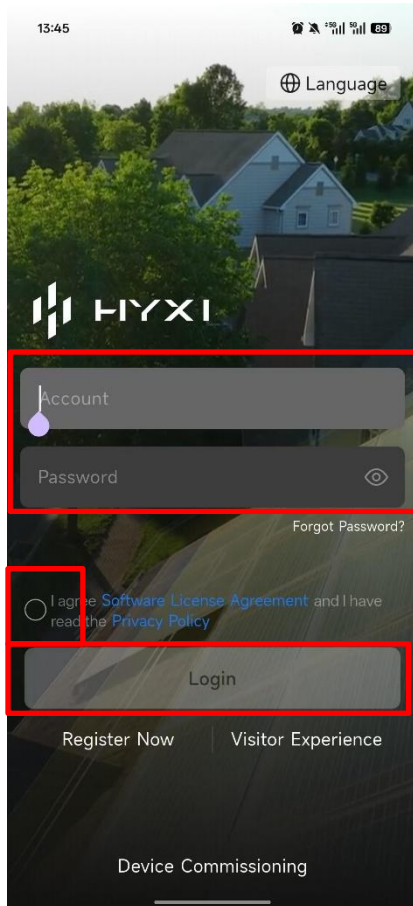

System Operation - Create Plant on APP

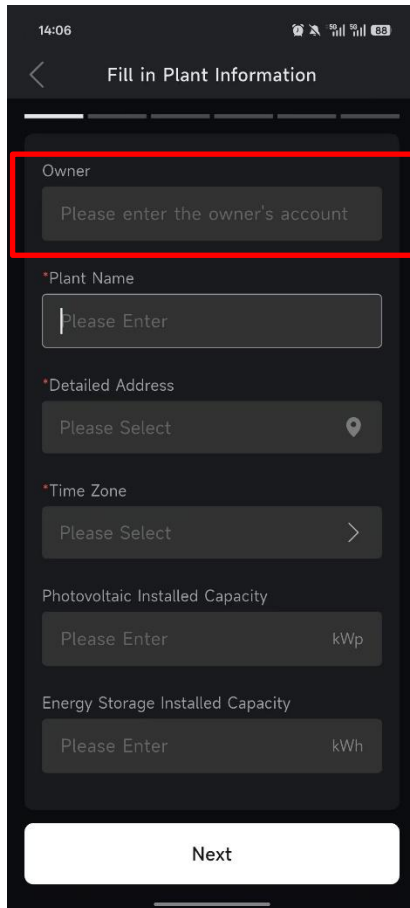

Please note:

After entering the end user's email address, the email box will receive a password email. This email address will automatically become the HYXI login account.



| CONTENTS

• 01
Overview

• 02
Installation

• 03
Configuration

• 04
Commissioning

System Operation-System Test

If everything is normal , Hyxipower staff signs the documents with the customer:

<Commissioning Acceptance Report> < Charge and Discharge Capacity Test Report)

Power-on Test	Ok or Not
Auxiliary power supply starts normally	
EMS starts normally. All lights green.	
BMS starts normally. All lights green.	
PCS starts normally. All lights green.	
EMS web page shows no alarm.	
SOC display in normal range.	
Protection Function Test	
Emergency stop function test: shutdown was normal.	
Smoke detector, heat detector, and combustible gas triggering test. Alarm can be triggered.	
Water immersion detection test. Alarm can be triggered.	
Door access control protection. Alarm can be triggered.	
erosol status detection.Alarm can be triggered.	

System Operation-System Test

Thermal Control Test	Ok or not
The liquid cooling system is operating normally.	
PCS fans are operating normally.	
Automatic start/stop logic is normal	
PCS Functional Test	
PCS standby status is normal	
PCS starts up normally	
PCS is operating normally in grid connection.	
Stable power output	
Charge / Discharge Test	
0.5C charging test was normal.	
0.5C discharging test was normal.	
SOC changes normally.	

System Operation-System Test

Communication Protection Test	Ok or Not
EMS-PCS Communication Interruption Protection	
EMS-BMS Communication Interruption Protection	
PCS-BMS Communication Interruption Protection	
EMS-Temperature control Communication Interruption Protection	
Meter Communication Interruption Protection	
Anti-Backflow Test	
Anti-backflow control logic is normal	
System Integration Test	
EMS VPP control normally.	
Power regulation response is normal.	
The running strategy is executing normally.	

System Operation-Normal Operating Mode

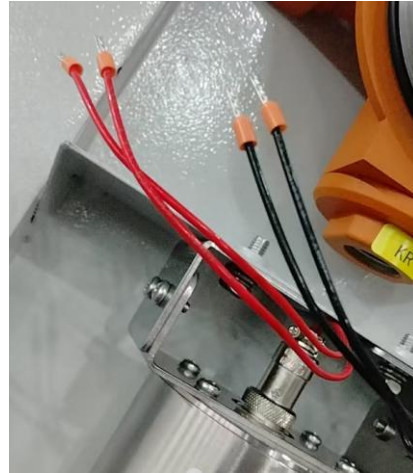

After the system is tested and found to be normal, it can be put into formal operation.

1. Connect the line to the aerosol fire extinguisher.

CMU-DI 1+ Black wire
CMU-DI 1- Black wire

Note: There are no positive or negative poles

SD-2 Red wire
HD-2 Red wire

Note: There are no positive or negative poles

Appendix: How to repair paint

Step1

Gently sand the damaged area with fine sandpaper to remove dirt or rust.

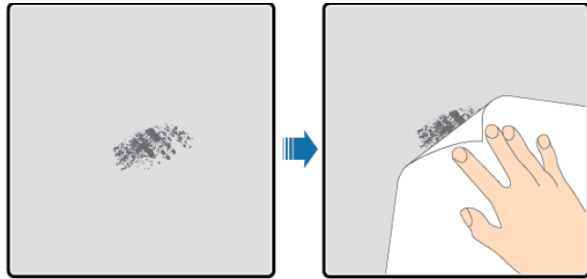

Step2

Moisten a cotton cloth with anhydrous ethanol and wipe the area to be sanded or repaired to remove surface dirt and dust, then wipe it dry with a clean cotton cloth.

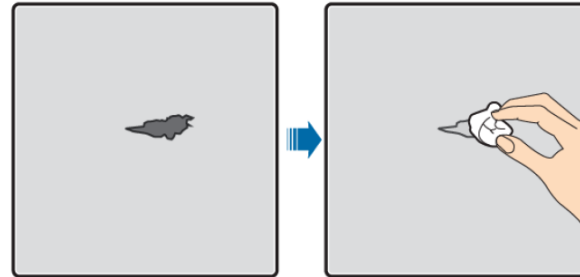

Step3

Depending on the extent of paint damage, choose one of the following methods—spray painting, brush painting, or spray gun painting—to evenly touch up the damaged areas until the damage is no longer visible.

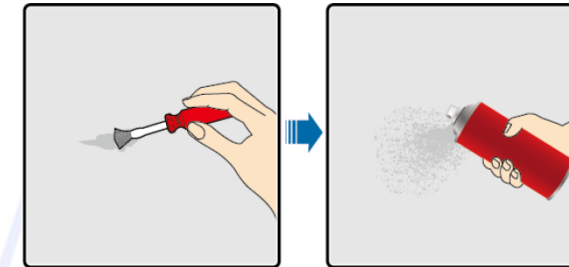

Step4

After painting, let it sit for about 30 minutes, then observe whether the touched-up area meets the requirements.

Note:

- Visually inspect the extent of paint damage on the equipment, and prepare the necessary tools and materials. The quantity of materials will be assessed on-site based on the specific needs of the touch-up work.
- Touch-up painting is strictly prohibited outdoors in inclement weather conditions such as rain, snow, strong winds, and sandstorms.
- The paint that meets the requirements has been prepared according to the color swatch provided at the time of shipment.

智慧能源 人人共享

Smarter Energy for All

