

# Single Phase Hybrid Inverter Installation Guide HYX-H(3~8)K-HS\_Single\_AU

Delivery and Service Center

V2.0 – 2026/03



# | CONTENTS

• **01**  
**Program Overview**

• **02**  
**Installation**

• **03**  
**App Configuration**

• **04**  
**FAQ**

# Topology

## DC Coupled Scenario

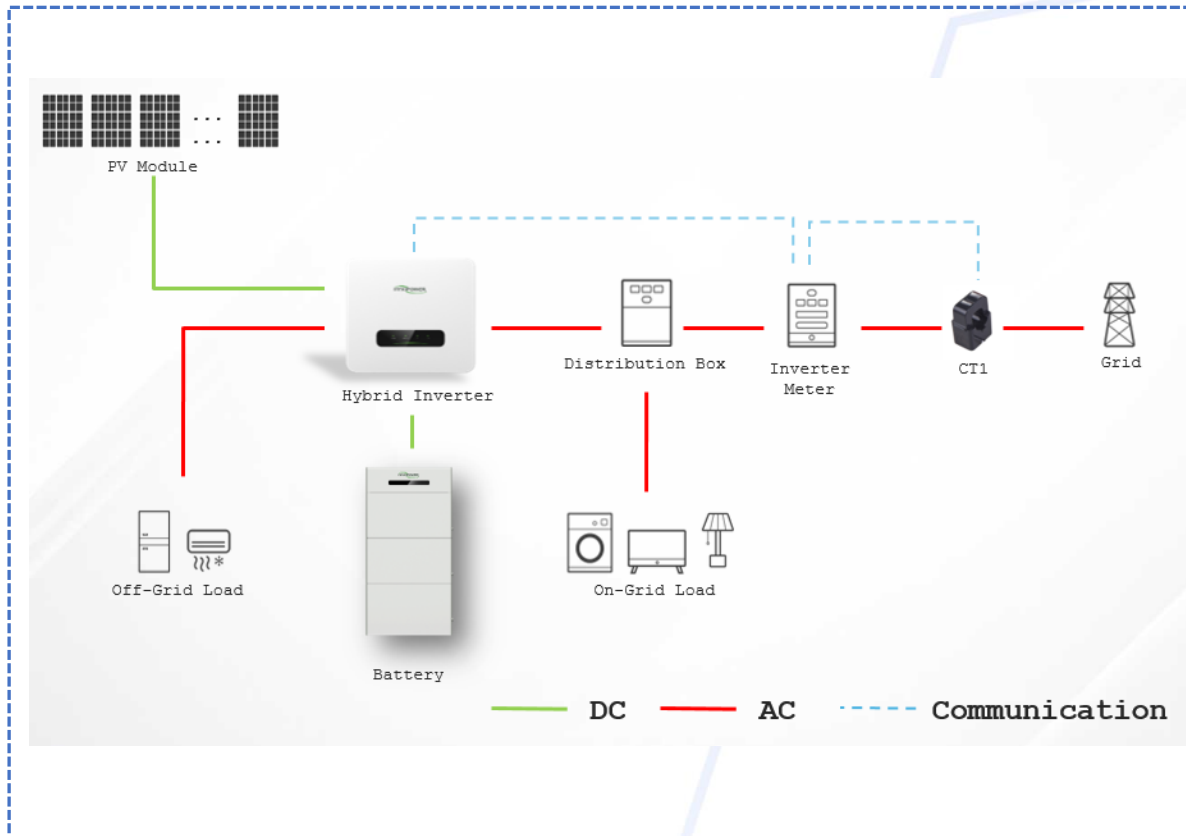

## AC Coupled Scenario

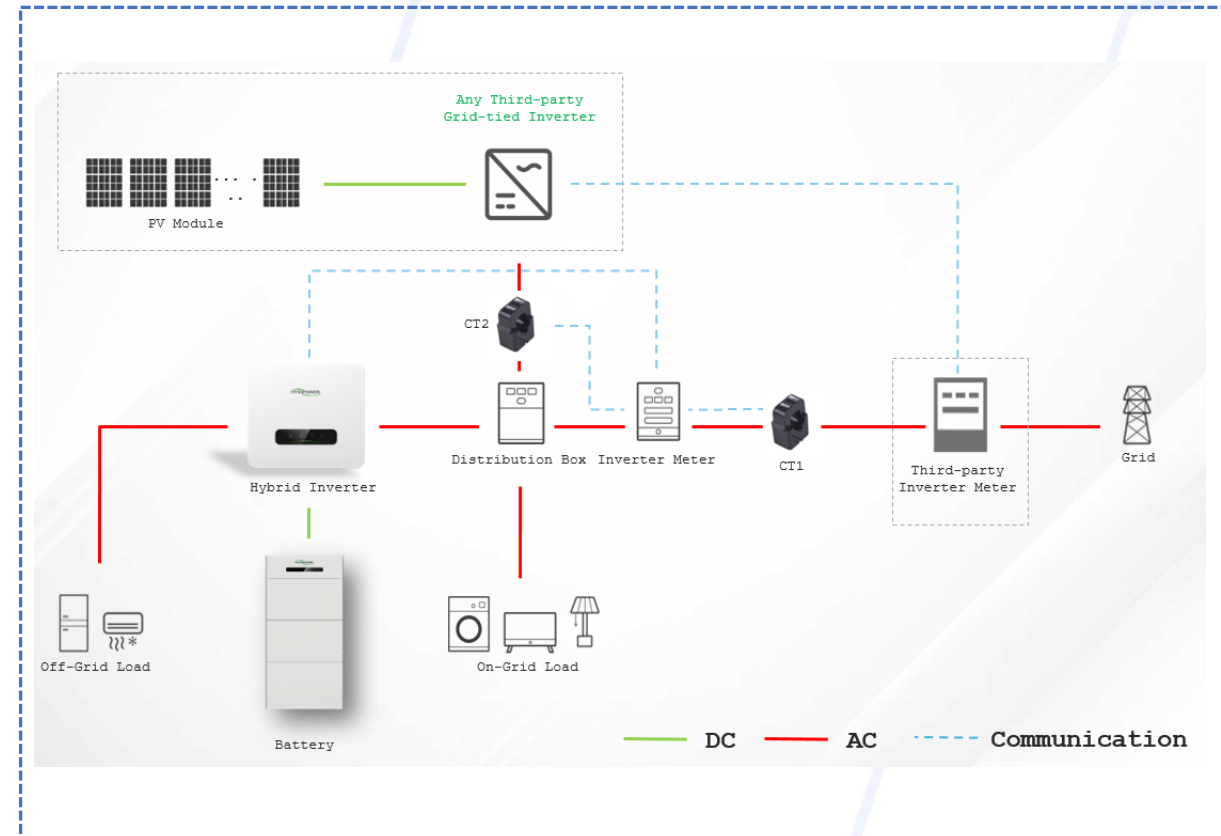

- DC coupled scenario is designed for new installation scenarios for efficient energy management.

- AC coupled scenario is designed for retrofit and upgrade scenarios for flexible upgrade. Compatible with any third-party inverter

# | CONTENTS

• 01  
Program Overview

• 02  
Installation

• 03  
App Configuration

• 04  
FAQ

# Site Survey - Environment Requirements

1. Suitable for both **indoor and outdoor** installation.
2.  $-30^{\circ}\text{C}$  to  $+60^{\circ}\text{C}$ , 0~100% relative humidity (RH).
3. **Select a shaded location** to avoid direct sunlight and protect against rain/snow.
4. **Ensure proper ventilation for heat dissipation.**
5. The mounting structure must support at least **4 times** the inverter's weight.,
6. Mount vertically or tilted backward  $\leq 15^{\circ}$  to optimize thermal performance.
7. Do NOT install forward-facing, backward-facing, upside-down, horizontally, or sideways.
8. For multi-unit installations, maintain  $\geq 300\text{mm}$  clearance between inverters.

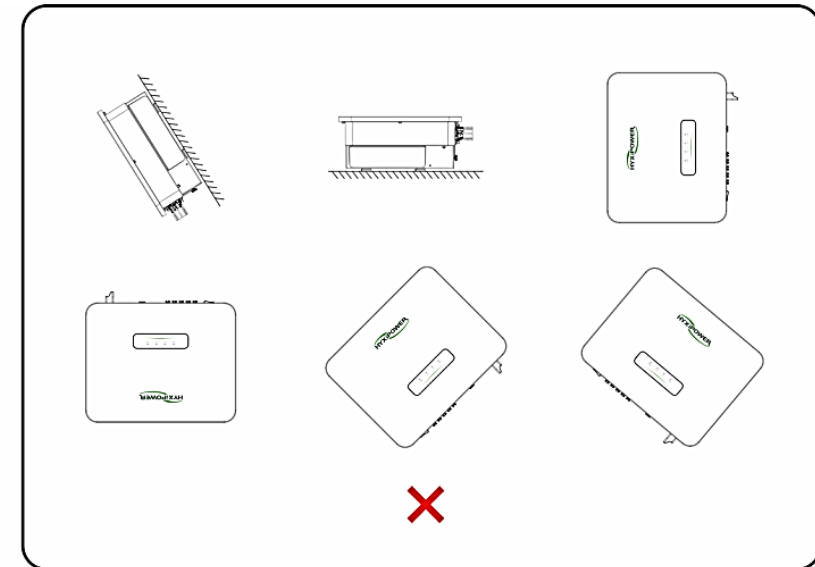
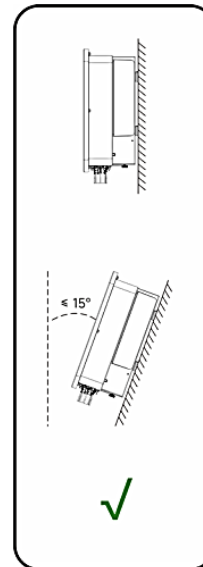
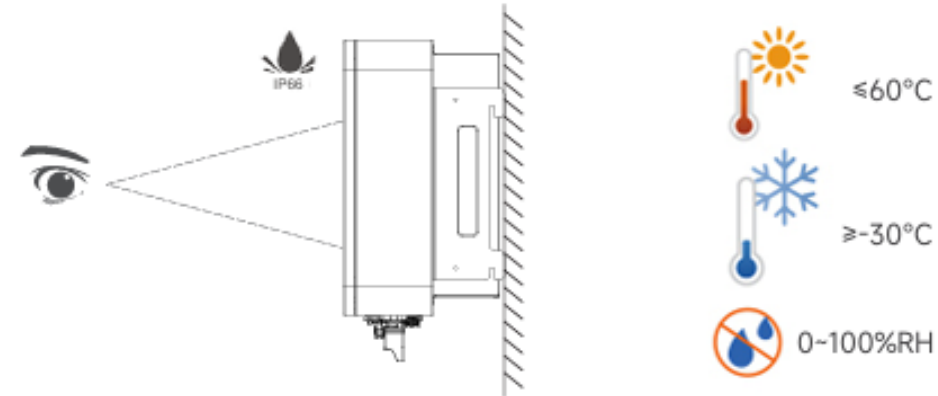







# Installation - Common Product List

The following product list is NOT included in the pre-sales configuration and must be purchased separately. Before system installation, ensure all devices and tools are fully prepared.

Number	Name	Explanation	Specifications
1	PV Cable	Cable for connecting photovoltaic panels to the inverter, compliant with outdoor multi-core copper cable standards (1000V, 18A).	4~10mm <sup>2</sup>
2	Communication Cable	485 communication cable for connecting the inverter and electricity meter.	RVVP two-core shielded cable, 0.5mm <sup>2</sup>
3	AC Output Cable	For AC-side wiring of the inverter, using a five-core outdoor copper cable.	4~10mm <sup>2</sup>
4	Backup Output Cable	For Backup-side wiring of the inverter, using a five-core outdoor copper cable.	4~10mm <sup>2</sup>
5	Ethernet Cable	For communication between the inverter and battery, a standard Ethernet cable is used. (Includes one 2-meter-long Ethernet cable; if the length is insufficient, purchase separately.)	Standard
6	Ground Wire	For equipment grounding purposes.	4~10mm <sup>2</sup>
7	Battery Power Cable	Power cable for connecting the battery and inverter, must comply with 600V and 35A standards. (Optional battery power cable can be selected when placing future product orders.)	6mm <sup>2</sup>

# Installation - Common Product List

The following product list is included in the pre-sales configuration.  
 Before system installation, verify that all devices and tools are fully prepared.

Number	Product	Picture	Explanation
1	Hybrid inverter		Includes one inverter and related inverter accessories.
2	Battery		Includes a Battery Distribution Unit (BDU) and battery modules for electrical energy storage.
3	1 Phase Meter With 2 CT		Measure circuit voltage, current, power, etc.
4	Current Transformer		Used to measure the grid-side AC current, enabling the inverter to control power output and prevent backflow and detect the power form 3rd inverter Note: During installation, the arrow must point toward the grid.
5	DCS Communication Stick		After registering the device to the cloud server, it can be centrally managed via the cloud platform.
6	Ethernet Cable		The device comes with a 2-meter-long Ethernet cable. If the length is insufficient, you will need to procure one separately.
7	Wall-mounted bracket		Wall-mounted bracket for securing the inverter.

# Installation - Tool Installation

## Installation Tool



Electric Drill



Heat Gun



Hex Key



Wire Stripper

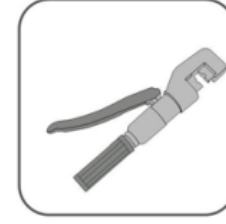

Hydraulic Pliers



Crimping Tool



Screwdriver



Marker Pen



Utility Knife

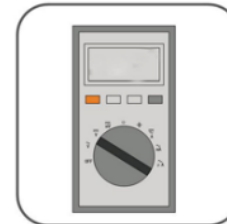

Multimeter

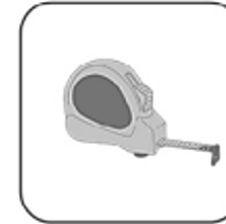

Tape Measure

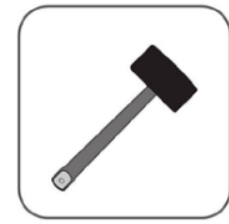

Hammer

## Protect Tool

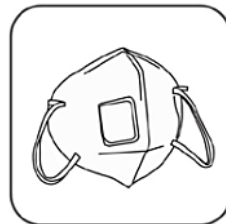

Protective Mask



Safety Glasses



Insulated Safety Shoes

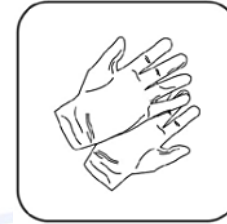

Insulating Gloves

# Installation - Product Unboxing Inspection

## Inverter Unboxing Inspection:

- Check whether the device hardware and ports are intact.
- Check whether the device accessories are intact.



# Installation - Terminal Introduction



PV  
Connectors

Battery  
Connectors

Meter  
Connector

Battery COM  
Connector

DRM Connector  
(Australia)

BACK UP  
Connector

GRID  
Connector

# Installation - BDU Introduction

Number	Explanation
1	Battery Distribution Unit (BDU)
2	BDU Display Panel
3	BDU Emergency Stop
4	High-voltage negative terminal
5	High-voltage positive terminal
6	Can port
7	Inverter com port
8	High-voltage power button
9	12V low-voltage power button



BDU exploded view diagram

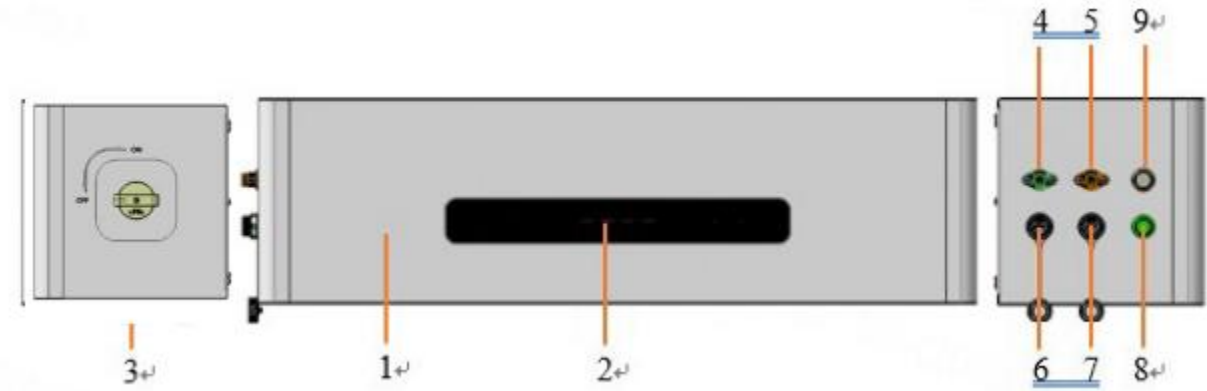

# Installation - Battery Installation

Battery / BDU  
Installation

Inverter  
Installation

Meter / CT  
Installation

DCS Installation

Wiring

System Startup

## Step1: Ground wire installation

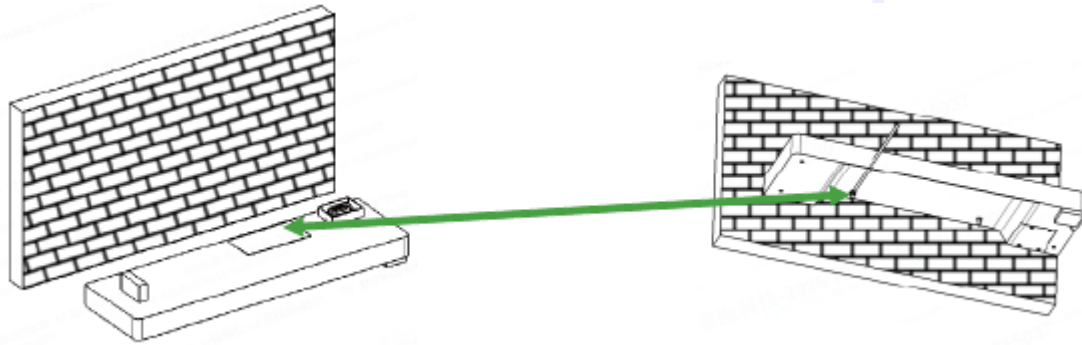

- Install the grounding wire onto the grounding stud according to the grounding prompt label instruction

## Step2: Base installation

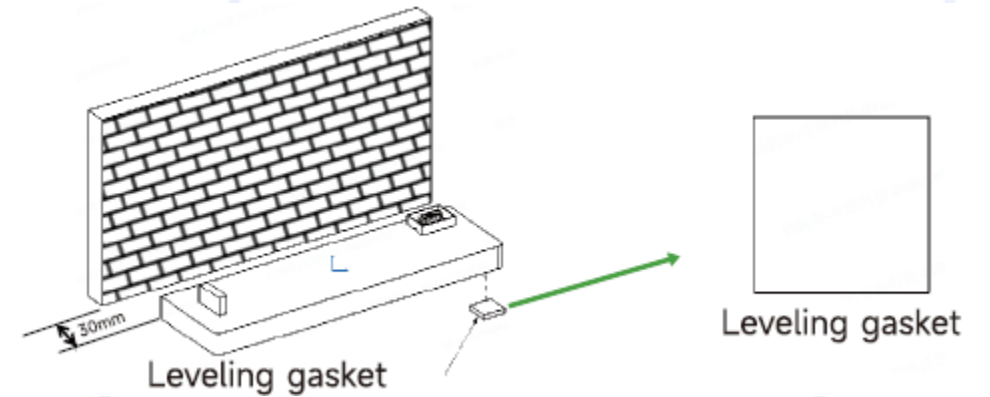

- Place the base at a specified distance of 30mm from the wall; use leveling pads to adjust the base until it is level.
- Gasket specifications: 35mm\*35mm\*5mm, 35mm\*35mm\*2mm. Selection can be made based on the actual on-site environment.

# Installation - Battery Installation

Battery / BDU  
Installation

Inverter  
Installation

Meter / CT  
Installation

DCS Installation

Wiring

System Startup

## Step3: Bracket positioning and installation

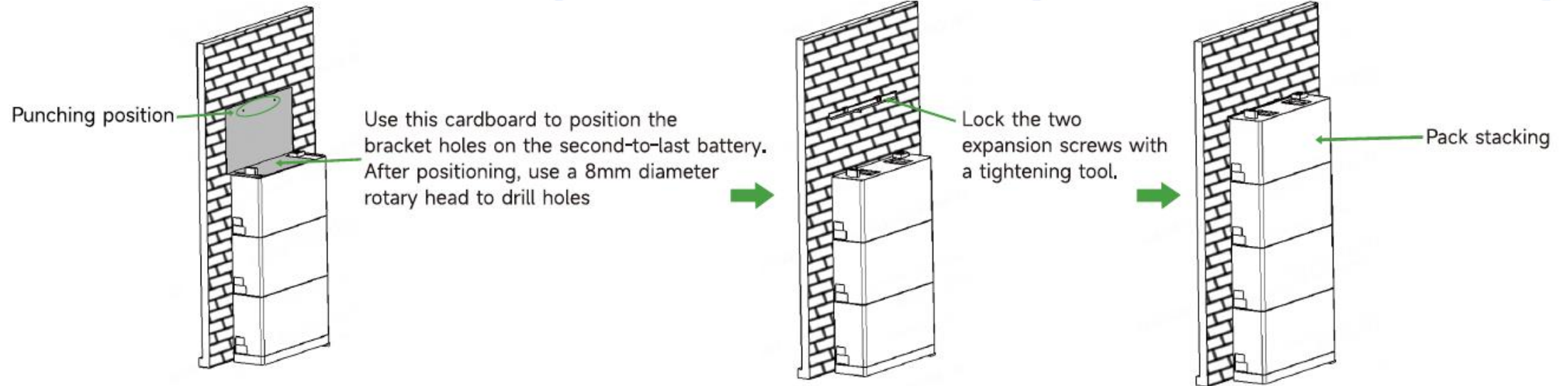

# Installation - Battery Installation

Battery / BDU  
Installation

Inverter  
Installation

Meter / CT  
Installation

DCS Installation

Wiring

System Startup

## Step4: Bracket installation

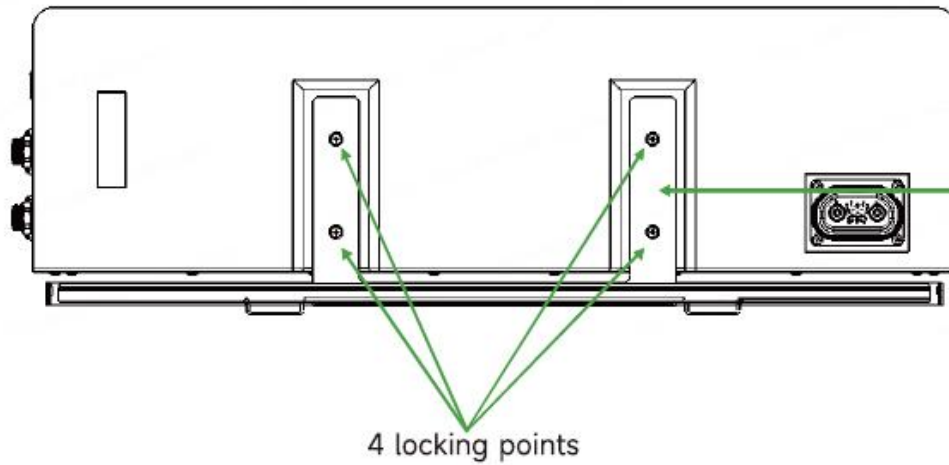

Lock 4 screws, install the anti tilt bracket, and secure the anti tilt bracket to the BDU.

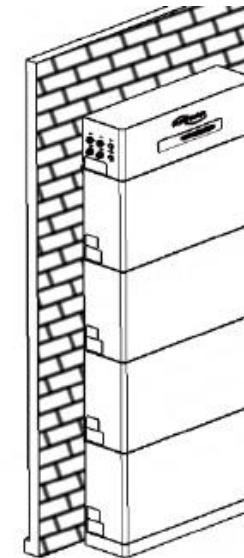

Installation completed.

# Installation - Inverter Installation

Battery / BDU  
Installation

**Inverter  
Installation**

Meter / CT  
Installation

DCS Installation

Wiring

System Startup

- The mounting bracket and inverter can be fixed in the following manner:

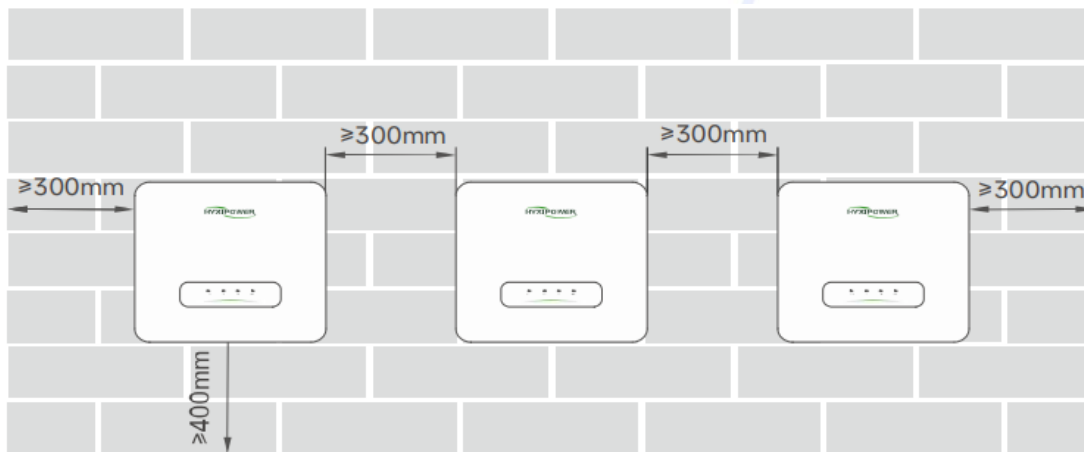
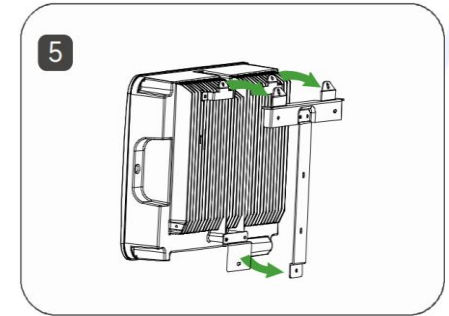
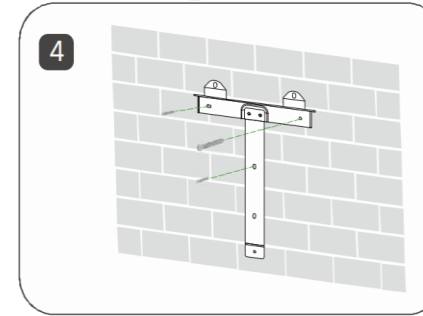
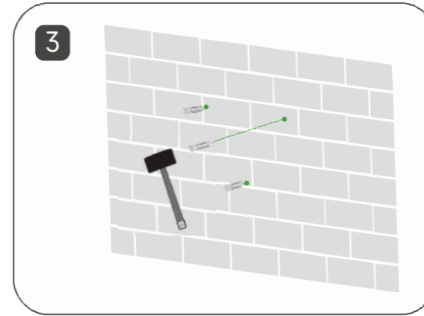
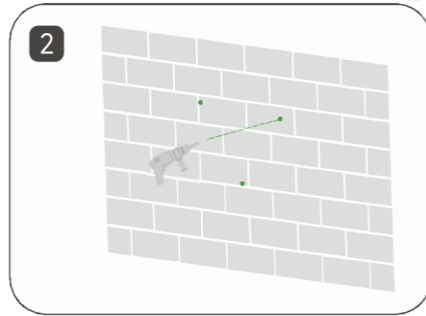
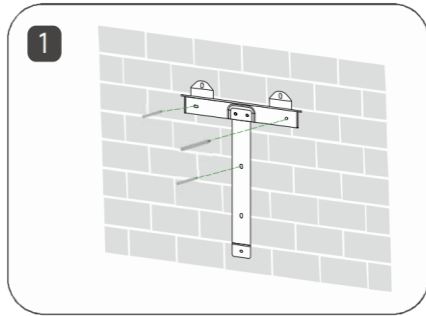

Mounting Bracket  
Specifications:

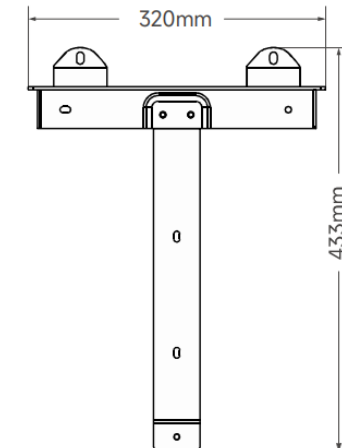

**Note: Before installing the equipment, ensure the solar panels are properly installed and all cables are laid in place.**

# Installation - Inverter Installation

Battery / BDU  
Installation

Inverter  
Installation

Meter / CT  
Installation

DCS Installation

Wiring

System Startup

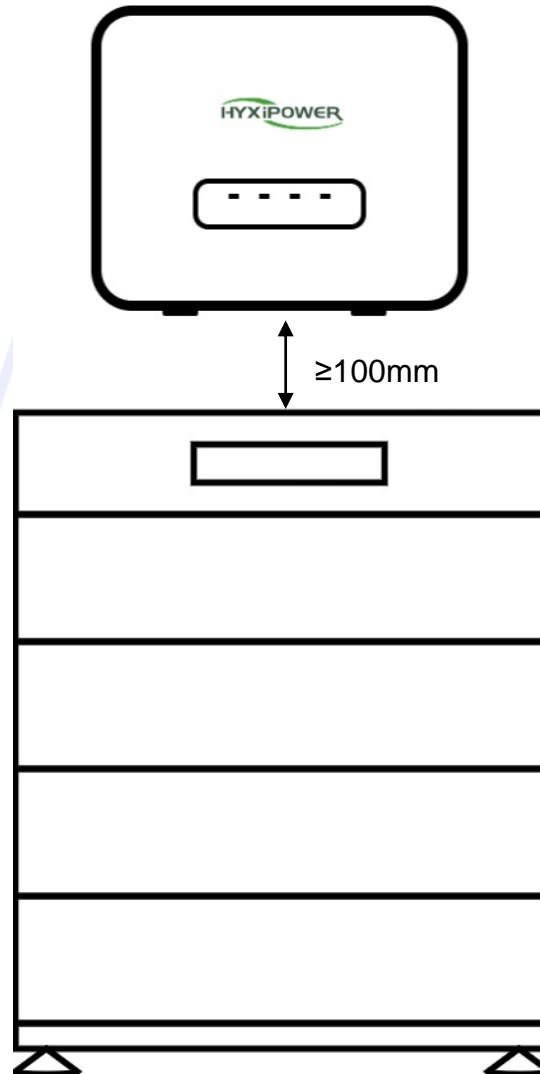

- The distance between the inverter and the battery must be at least 100 mm.

# Installation – Meter/CT Installation

Battery / BDU Installation

Inverter Installation

Meter / CT Installation

DCS Installation

Wiring

System Startup

(1) A two-CT meter has two current transformers: the yellow CT clamps onto the main AC cable, and the green CT clamps onto the third-party inverter. **The arrows on both CTs must point toward the grid when they are installed.**



Yellow CT: measure the current on the main AC cable

Green CT: measure the current on the third-party inverter AC cable

(2) The communication wiring from the meter must ensure that the wire colors on **ports 1 and 2** of the inverter-side meter terminal match the colors on **ports A and B** of the meter's RS485 interface.



(3) On-site, for the dual-CT communication cable, the terminal order is **white on the left and blue on the right**, and connect L and N in the port

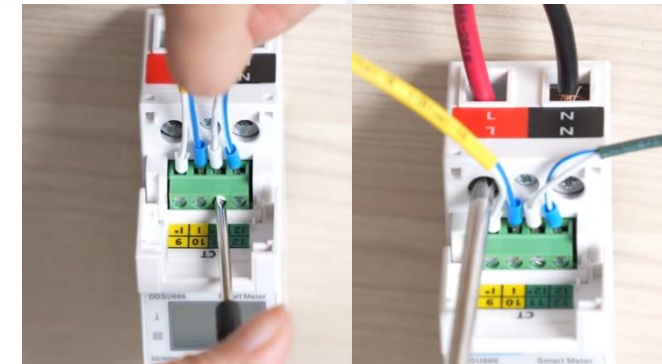

# Installation - DCS Installation

Battery / BDU  
Installation

Inverter  
Installation

Meter / CT  
Installation

DCS Installation

Wiring

System Startup

## 1、DCS Installation(4G Version )

**Step1:** Remove the DCS protective cover and insert the SIM card.

**Step2:** Install the DCS waterproof cover

**Step3:** Remove the waterproof cover from the inverter communication interface.

**Step4:** Insert the DCS into the corresponding communication terminal at the bottom of the inverter and tighten it to ensure a secure connection.

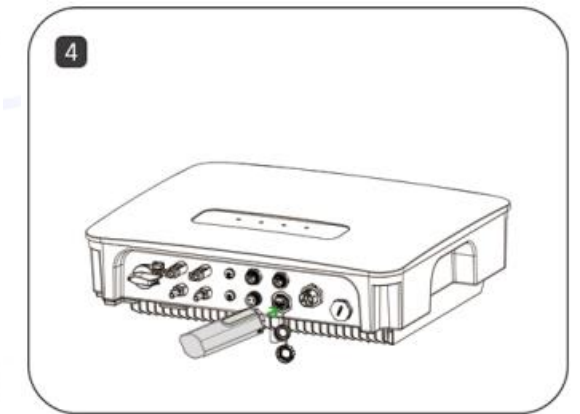
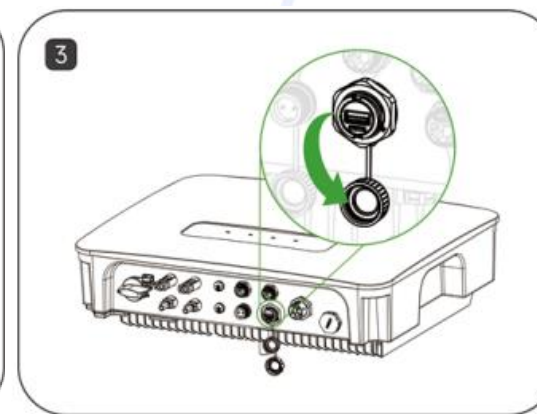
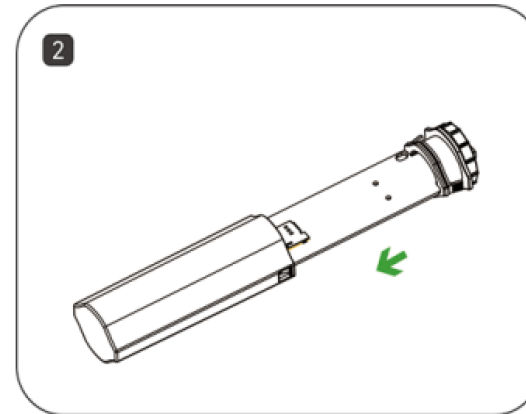
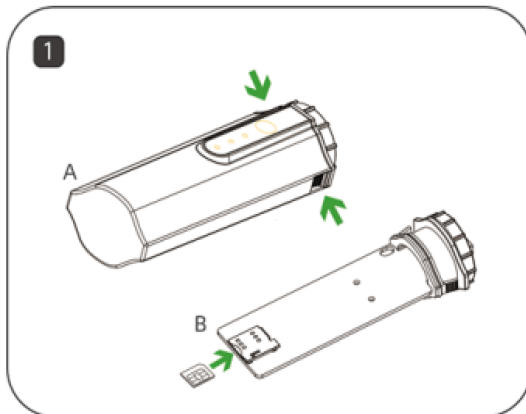

# Installation - DCS Installation

Battery / BDU  
Installation

Inverter  
Installation

Meter / CT  
Installation

DCS Installation

Wiring

System Startup

## 2、DCS Installation (The WiFi version does not require SIM card installation or removal.)

**Step1:** Remove the waterproof cover from the inverter's communication interface.

**Step2:** Insert the DCS into the corresponding communication terminal at the bottom of the inverter, tighten it, and ensure it is securely connected.

Note: For the WiFi version, if the on-site signal is weak (below -60 dBm), it is recommended to add a WiFi repeater to enhance the network signal. Otherwise, there is a risk that device data may fail to upload to the platform.

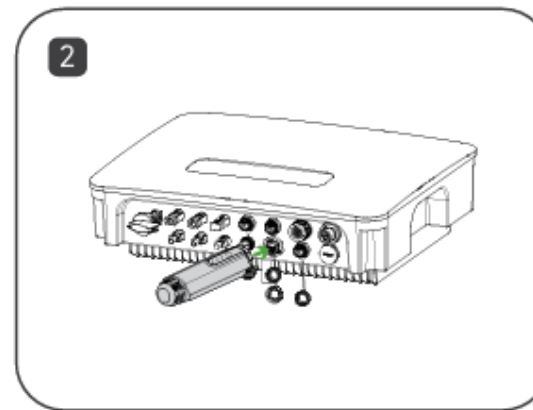
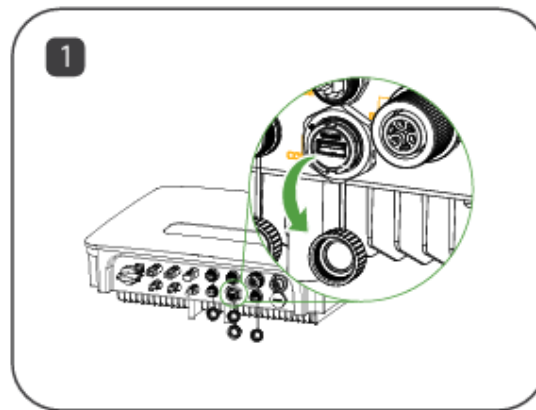

# Installation – Wiring



## AC Coupled Scenario

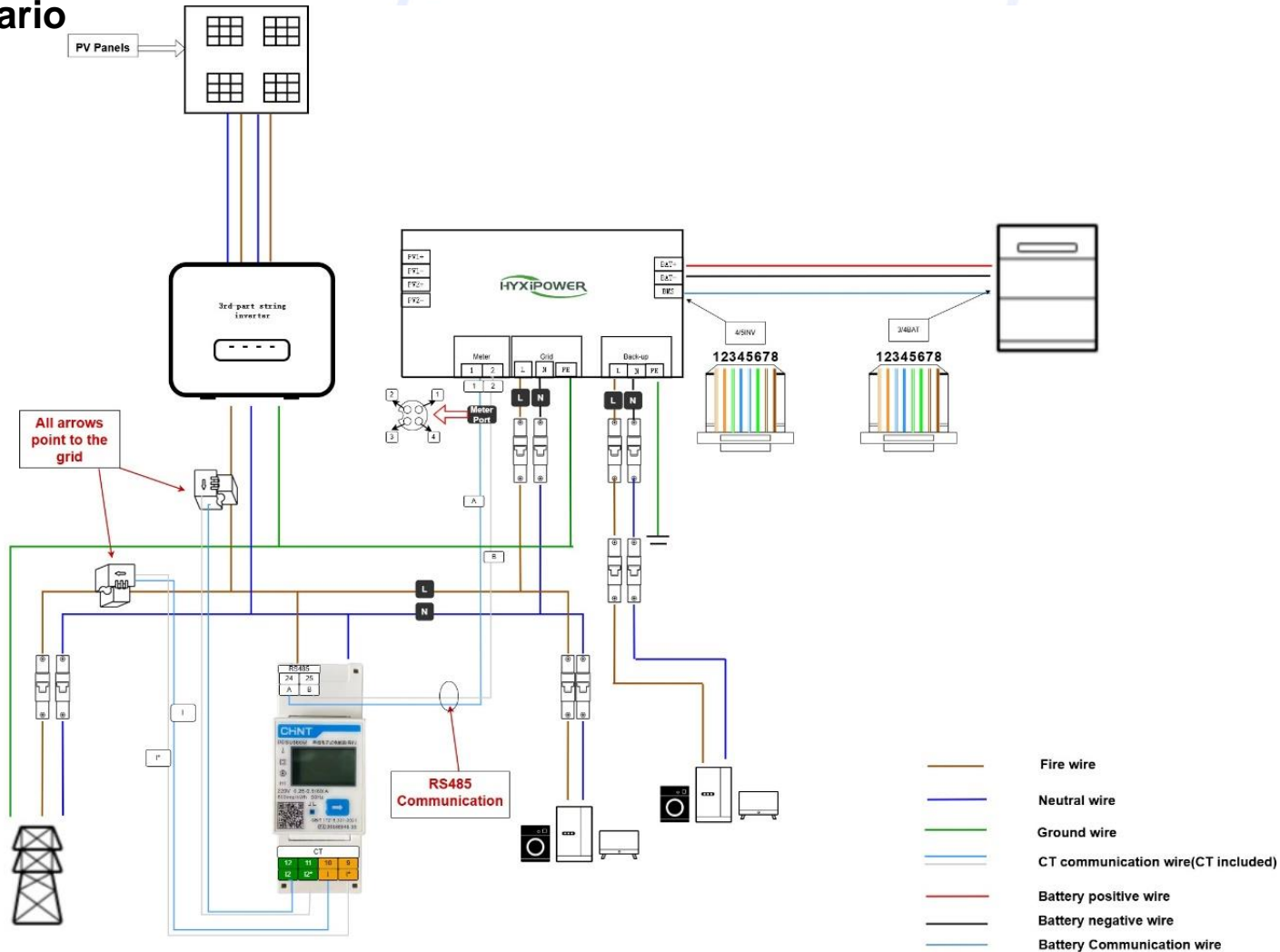

# Installation – Wiring



## DC Coupled Scenario

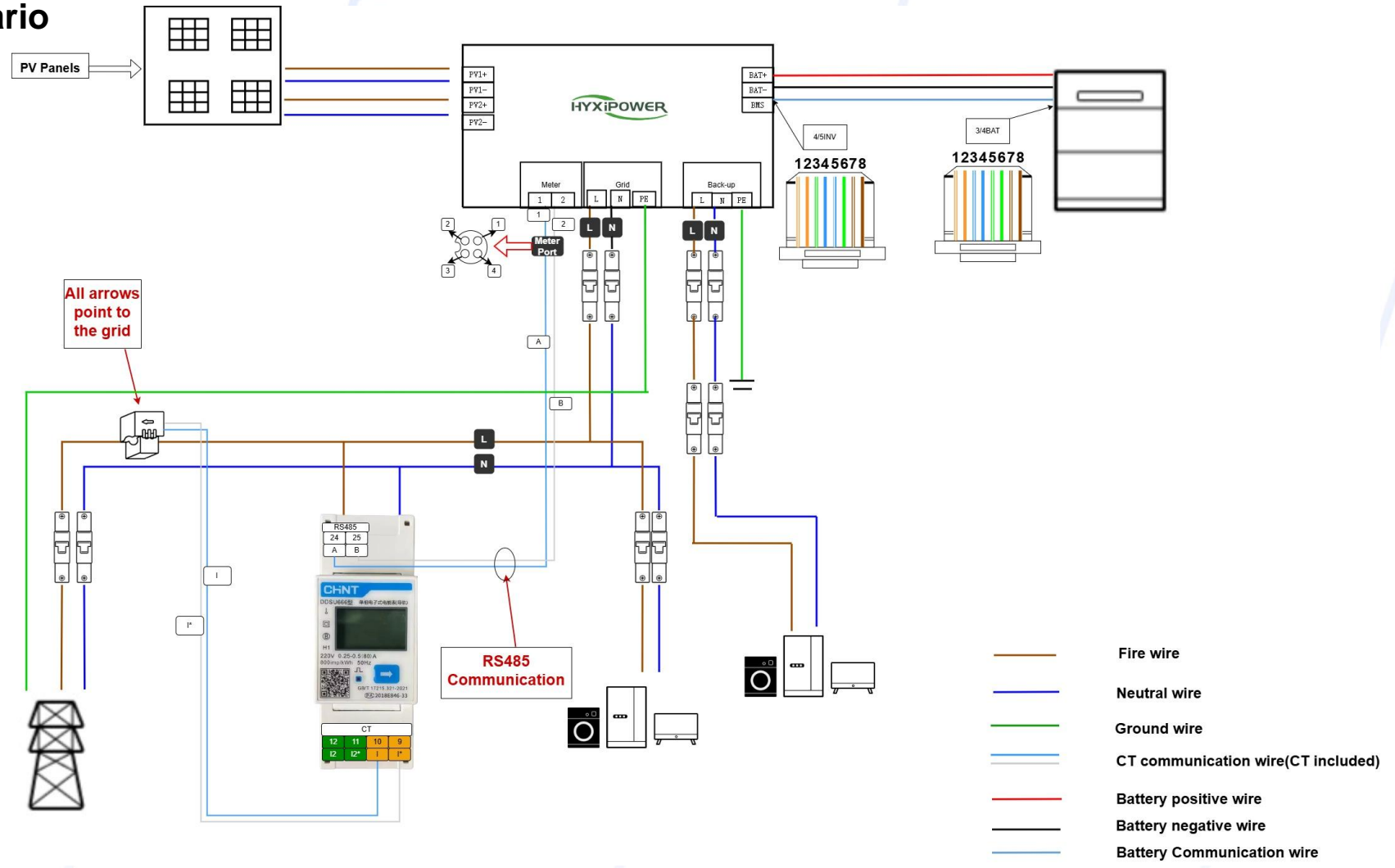

# Installation – Wiring

Battery / BDU  
Installation

Inverter  
Installation

Meter / CT  
Installation

DCS Installation

Wiring

System Startup

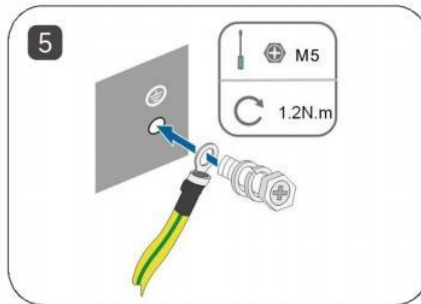
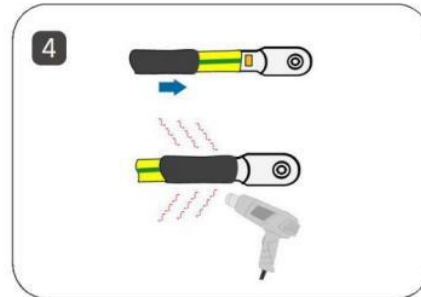
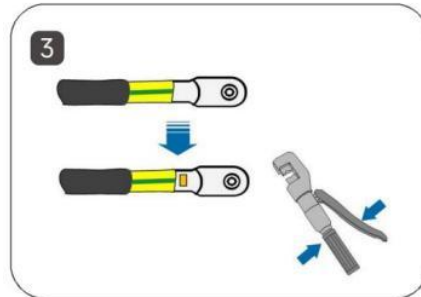
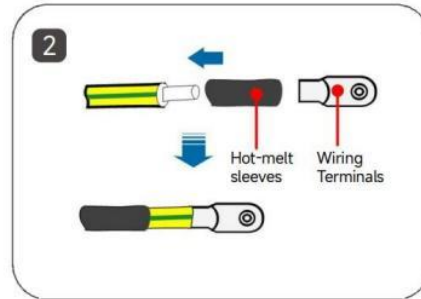
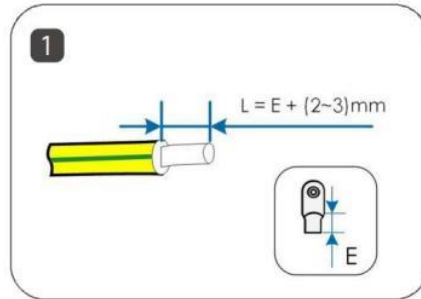

**Step 1** : Strip off a certain length of insulation

$L=E+(2-3)mm$  .

**Step 2** : Pass the cable through the hot melt sleeve and insert it into the terminal block.

**Step 3** : Use crimping pliers to tightly connect the terminal blocks and cables .

**Step 4** : Adjust the hot melt sleeve to cover the end of the terminal block and the power cord, and use a hot air gun to blow the hot melt sleeve to cover the end of the power cord and terminal block.

**Step 5** : Use a screwdriver to fix the ground wire to the inverter ground position.

# Installation – Wiring

Battery / BDU  
Installation

Inverter  
Installation

Meter / CT  
Installation

DCS Installation

Wiring

System Startup

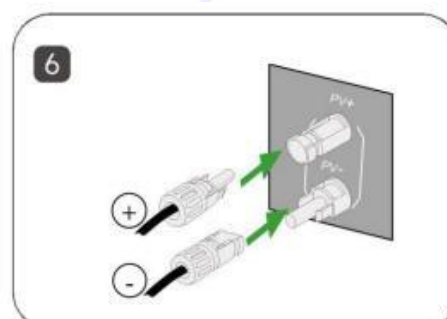
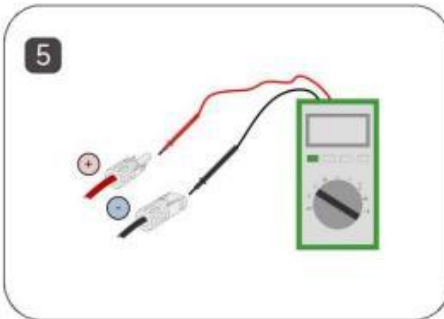
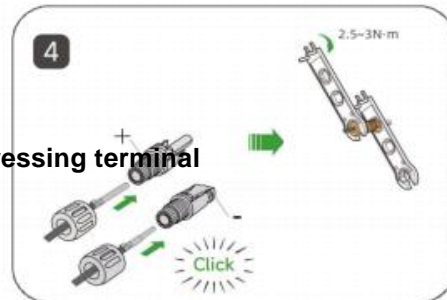
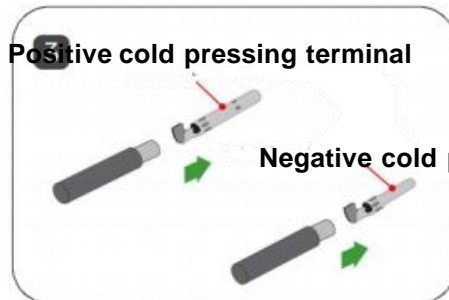
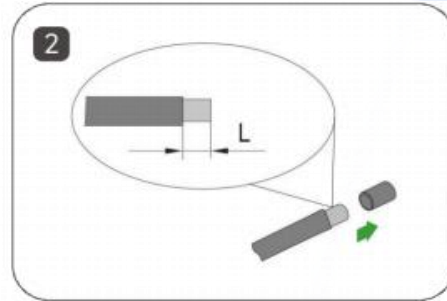
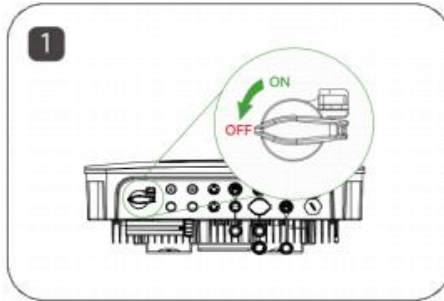

**Step 1:** Keep the switch on the inverter turned off.

**Step 2:** Strip all DC cables insulation by approximately 7 mm.

**Step 3:** Use crimping pliers to bundle the cold-pressed terminals to the cables. Note that the positive and negative terminals are different and need to be distinguished.

**Step 4:** Insert the cable through the cable sealing sleeve, insert it into the insulating sleeve and fasten it, and pull the cable gently to make sure it is tightly connected. Use 2.5 ~ 3N·m force to tighten the sealing sleeve and insulation sleeve.

**Step 5:** Use a multimeter to check whether the polarity of the photovoltaic string connecting cable is correct.

**Step 6:** Connect the PV connector to the corresponding terminal on the inverter until you hear a "click" sound.

# Installation – Wiring

Battery / BDU  
Installation

Inverter  
Installation

Meter / CT  
Installation

DCS Installation

Wiring

System Startup

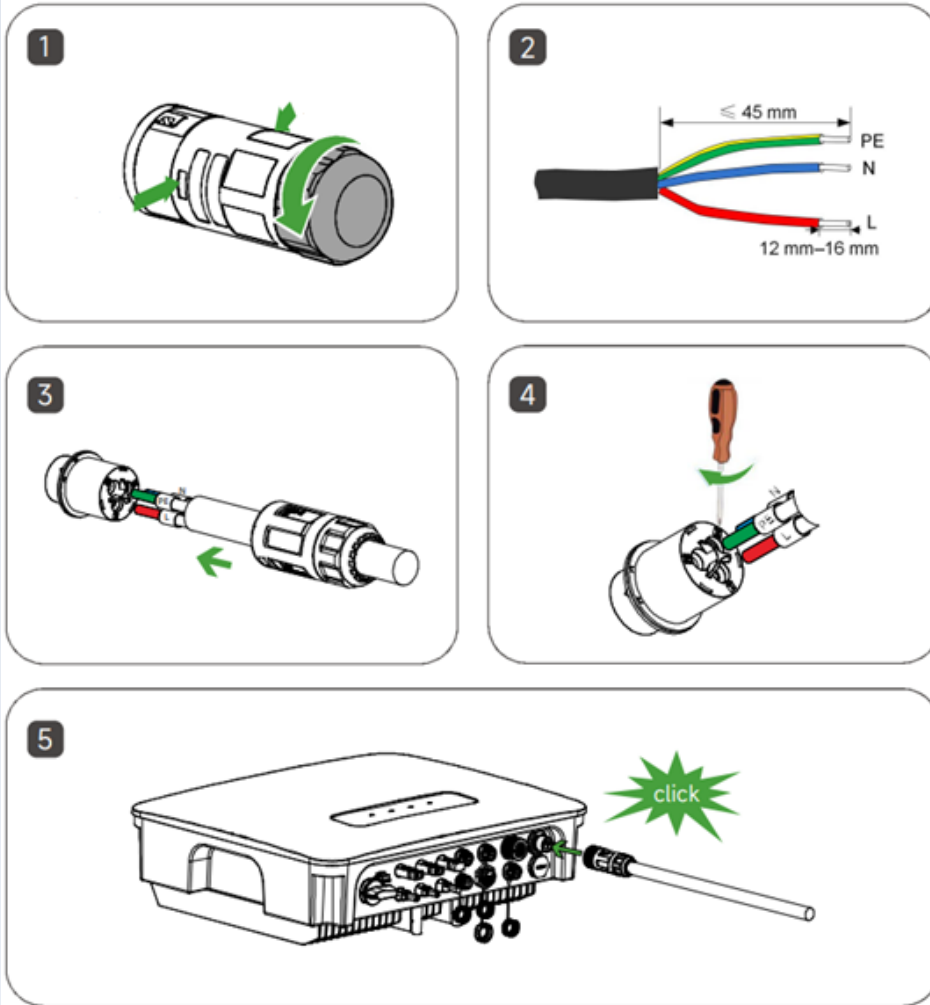

**Step 1:** Unscrew and detach the AC-side connector.

**Step 2:** Strip a section of the power cable's protective and insulation layers as shown, then crimp the cold-press terminals tightly onto the wires using a crimping tool.

**Step 3:** Loosen (but do not fully remove) the three hex screws. Insert the three prepared wires from Step 2 into their corresponding screw holes.

**Step 4:** Secure all wires by tightening the three hex screws.

**Step 5:** Reassemble the connector. Attach the AC connector to its corresponding terminal until you hear a "click" sound.

**Note:** The AC side uses a female connector, while the backup load side uses a male connector.

# Installation – Wiring



We provide the INV-BAT communication cable in the box. There are two stickers on it. The "3/4BAT" sticker side connects to the battery's CAN port, and the "4/5INV" sticker side connects to the inverter's BMS port.

But in case of the damage on this communication cable and you want to make one by yourself, the current wiring sequence is as follows:

3/4BAT: Orange-White, Orange, Blue-White, Blue, Green-White, Green, Brown-White, Brown

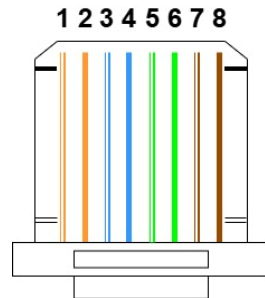

4/5INV: Orange-White, Orange, Green-White, Blue-White, Blue, Green, Brown-White, Brown

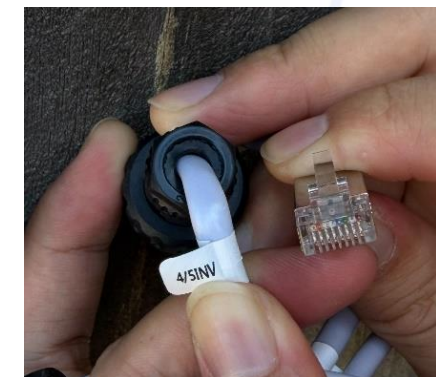
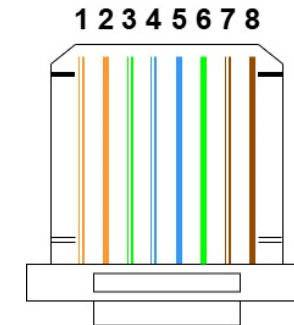

# Installation – System Startup

Battery / BDU  
Installation

Inverter  
Installation

Meter / CT  
Installation

DCS Installation

Wiring

System Startup

1. Turn on the AC circuit breaker.



2. Turn on the DC switch on the inverter.

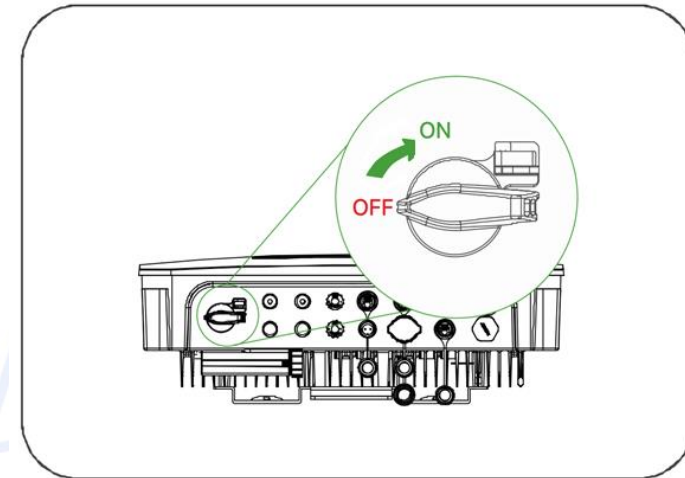

# Installation – System Startup

Battery / BDU  
Installation

Inverter  
Installation

Meter / CT  
Installation

DCS Installation

Wiring

System Startup

3. Before powering on the battery, the emergency switch on the right side of the BDU must be turned to ON, or it may damage the inverter. Then turn on 12V button briefly on the left side of BDU. If you want to shut down the battery, long press the POWER then short press the 12V

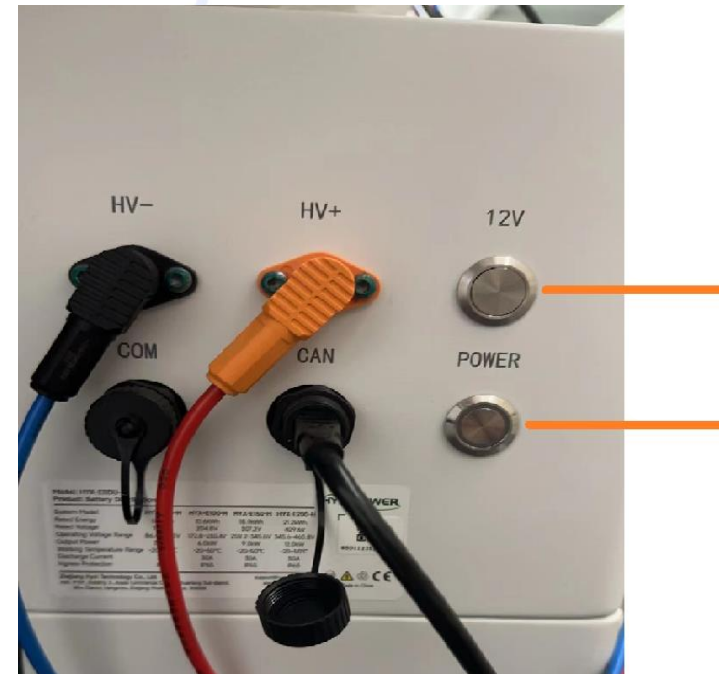

# Installation – System Startup



4. Verify the inverter's indicator light status. The light status shown below indicates normal operation.

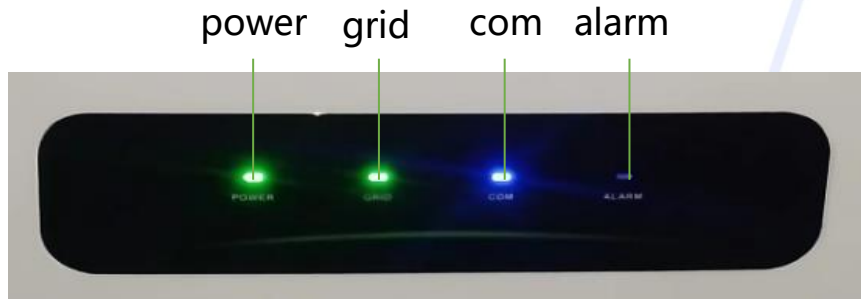

Normal signs are POWER, GRID and COM are on, ALARM is off.

NO.	Indicator	Status	Explanation
1	POWER	Solid	Inverter Power on
		Off	Inverter Power off
2	GRID	Solid	Grid Side normal
		Average blinking	Grid Side abnormal
		Double blinking	Not connected with grid
3	COM	Solid	Communication normal
		Average blinking	Communication failure between inverter and meter
		Double blinking	Communication failure between inverter and battery
		Off	Inverter communication failure with both meter and battery
4	ALARM	Off	No alarm from inverter
		Average blinking	Alarm from inverter
		Double blinking	Other alarms

# Installation – System Startup

Battery / BDU  
Installation

Inverter  
Installation

Meter / CT  
Installation

DCS Installation

Wiring

System Startup



# | CONTENTS

• 01  
Program Overview

• 02  
Installation

• 03  
App Configuration

• 04  
FAQ

# App Configuration

Registration

Commission

NMI  
Registration

The entire process requires 2 email accounts: Organization and Owner.

**Step 1:** Download the APP and **register**

## Method 1

Search "Hyxipower " in the Application Store

- APP store (IOS)
- Google play

## Method 2

Scan the QR code download the APP

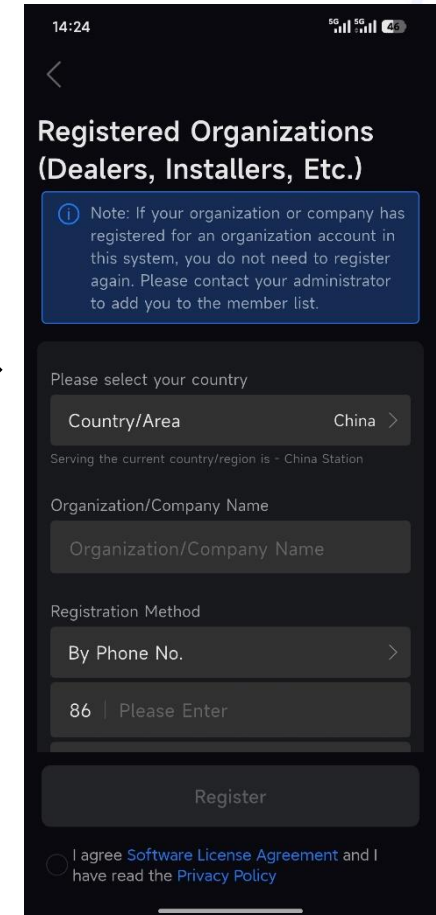
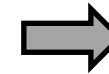
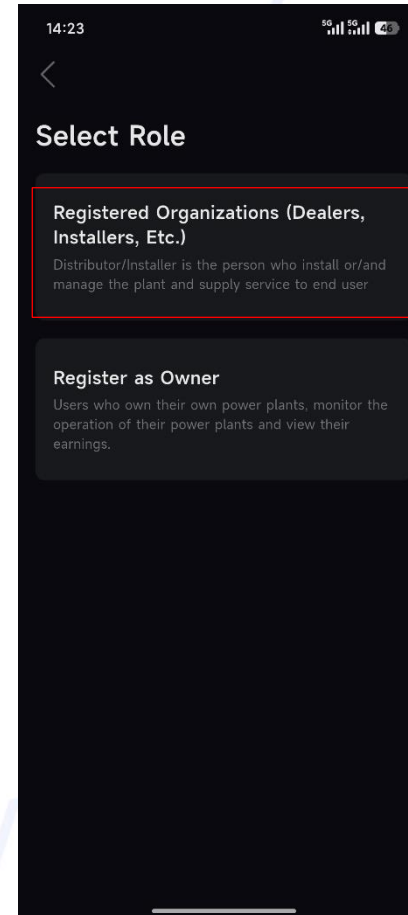
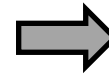
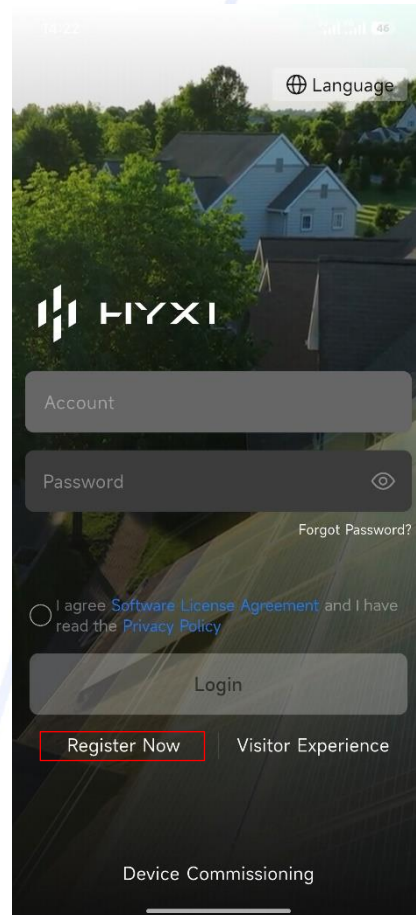

# App Configuration

Registration

Commission

NMI  
Registration

**Step1:** Click **Add Plant**. Then fill in the plant information. Then scan the QR code of the Data Communication Stick. If failed ,click the Importation. After that, click Next

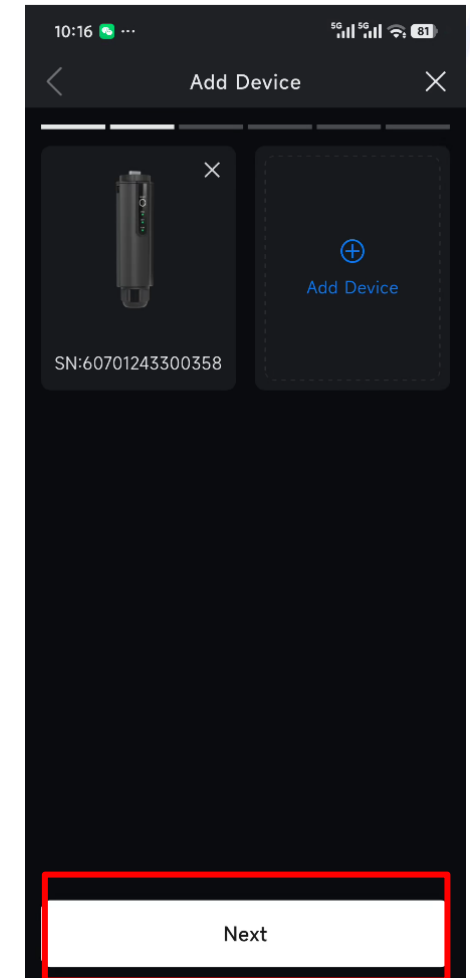
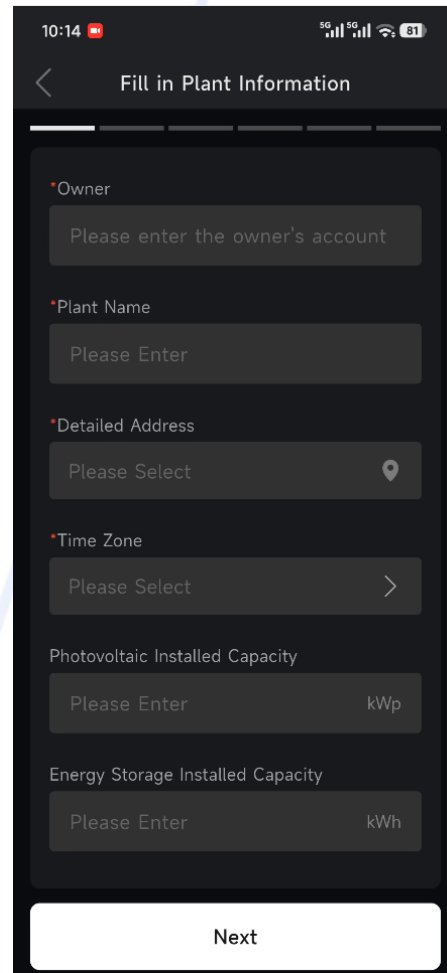
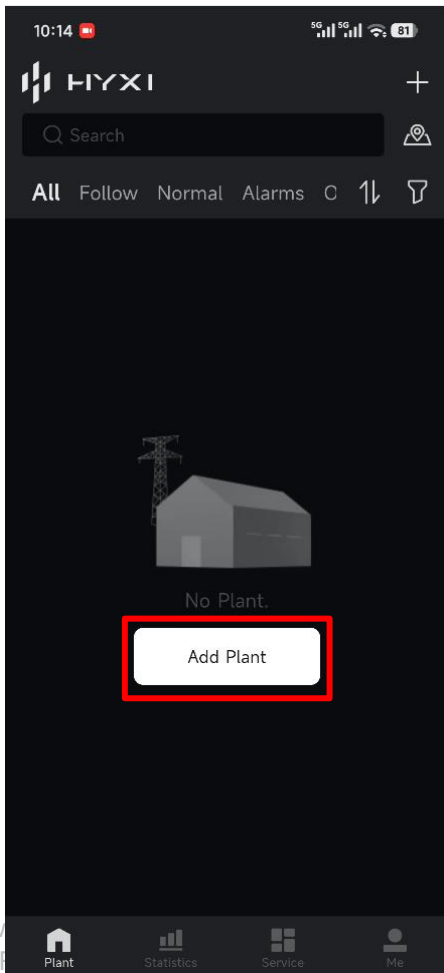

# App Configuration

Registration

Commission

NMI  
Registration

**Step2:** APP will connect with DCS, and do the network configuration, make sure that the Wi-Fi Name and password is correct. Then app will detect whether the inverter and DCS need upgrade, then click "Upgrade". The upgrade will take a amount of time.

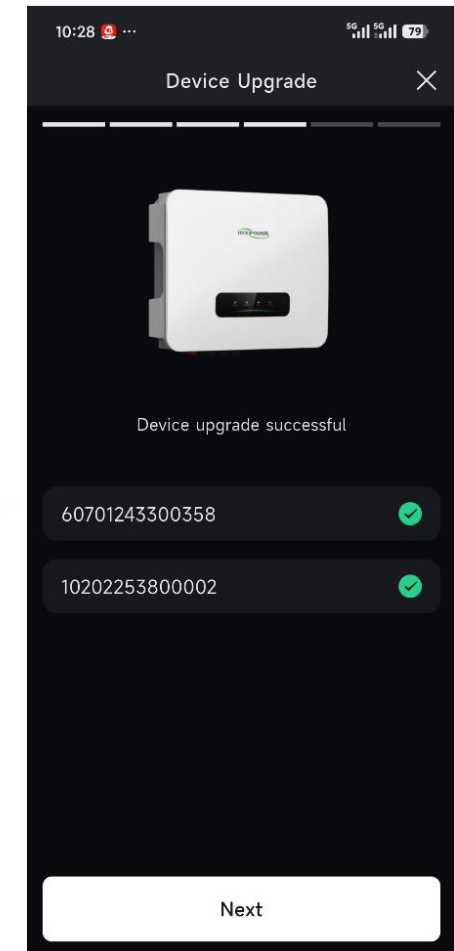
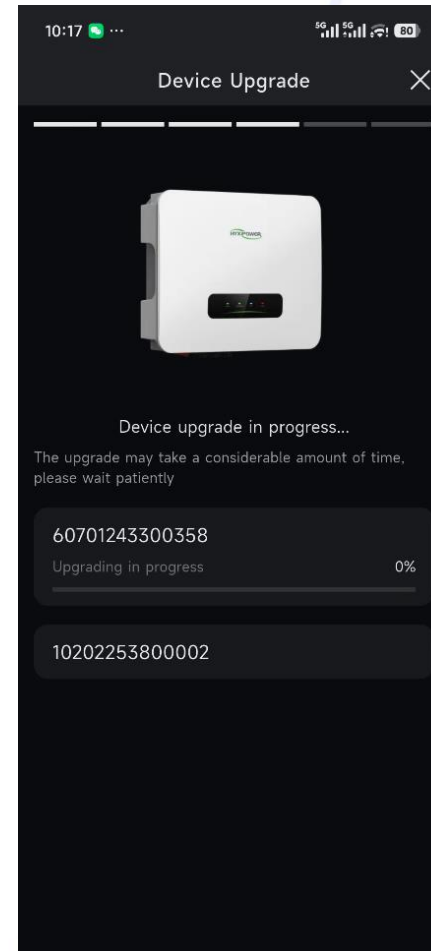
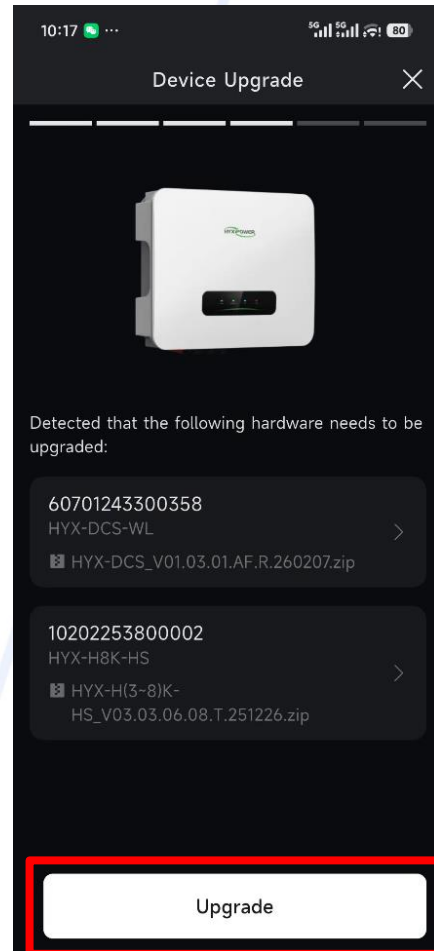

# App Configuration

Registration

Commission

NMI  
Registration

**Step3:** Choose the On-grid protection file and type the On-grid buy-in power limit. Then app will run the self inspection. After the self inspection, the plant create successfully, click Plant Configuration to improve the basic information of the plant.

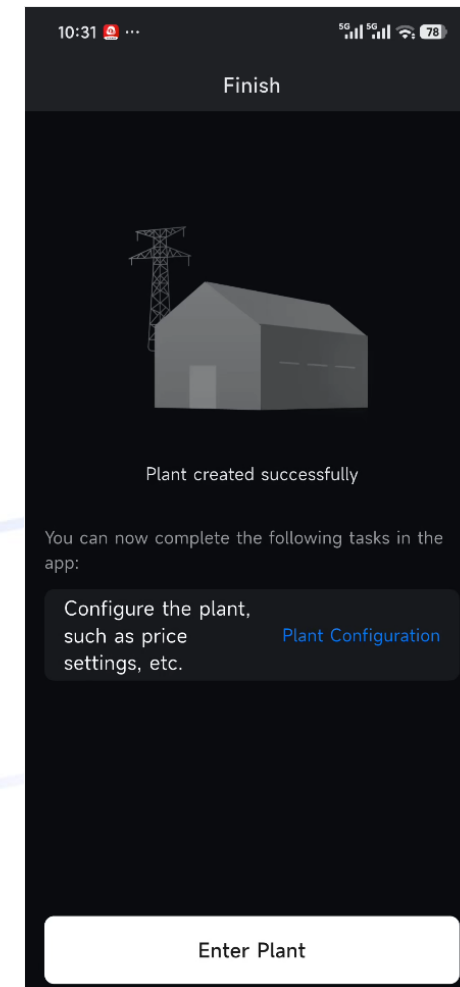
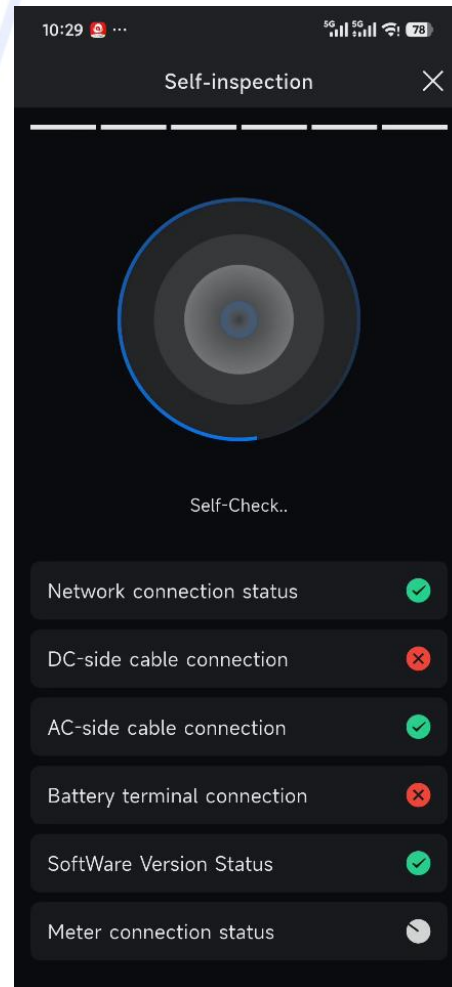
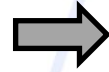
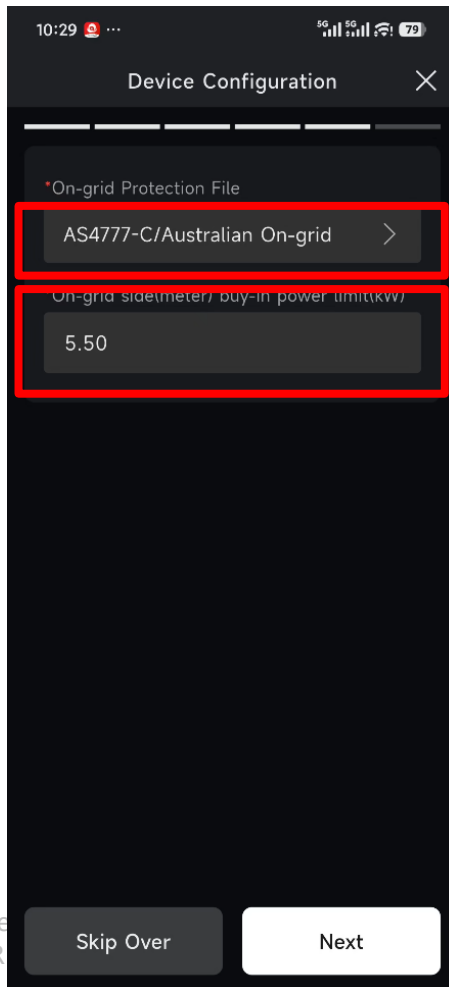

# App Configuration

Registration

Commission

NMI  
Registration

**Step1:** When first accessing the plant information page, a prompt will appear for NMI registration. Click “Plant Management” — “NMI Setting”.

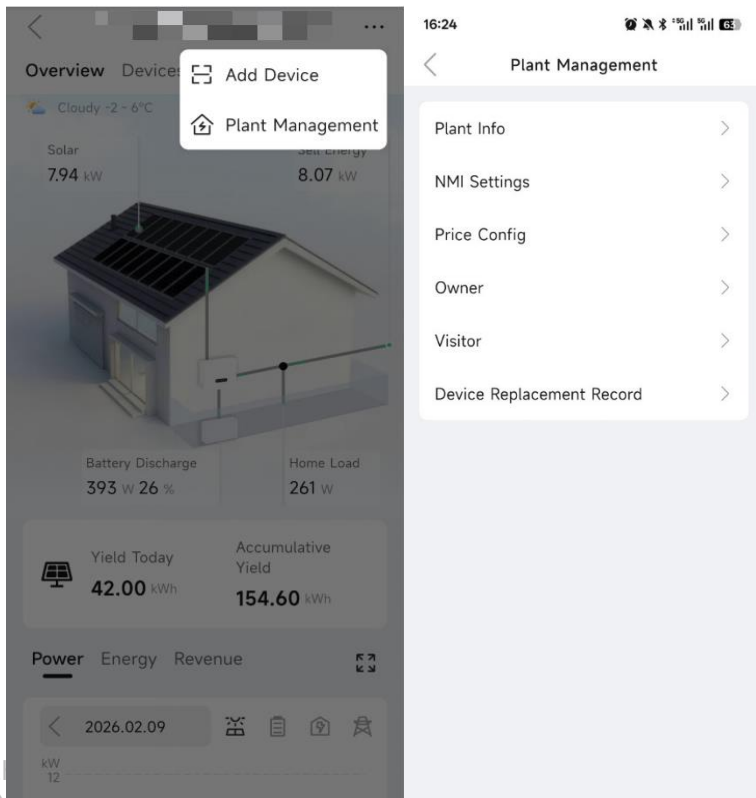

**Step1:** Select the agent, and enter NMI. Confirm that both agent and NMI are correct before proceeding with registration.

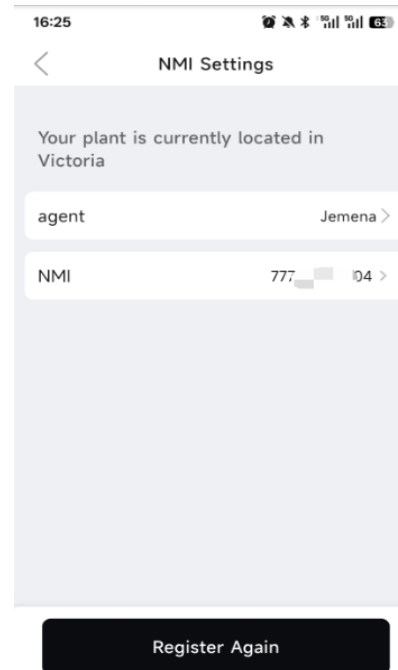

✓ By registering via this NMI to Jemena, devices under this plant will execute instructions from Jemena, and I confirm that user authorization has been obtained.

**Step3:** When failing to register, a prompt will appear. In this case, please verify the agent and NMI.

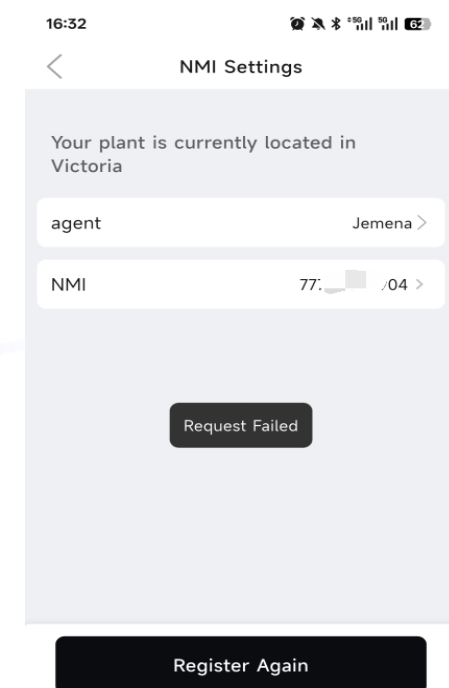

✓ By registering via this NMI to Jemena, devices under this plant will execute instructions from Jemena, and I confirm that user authorization has been obtained.

# App Configuration

Registration

Commission

NMI  
Registration

**Step4:** Once registration is successful, the LFDI will be displayed on the page and can be copied.

If agent is **Jemena**, then the installer should submit a CSIP-AUS commissioning application via the Jemena portal. Once submitted, Jemena will register the device in the production environment.

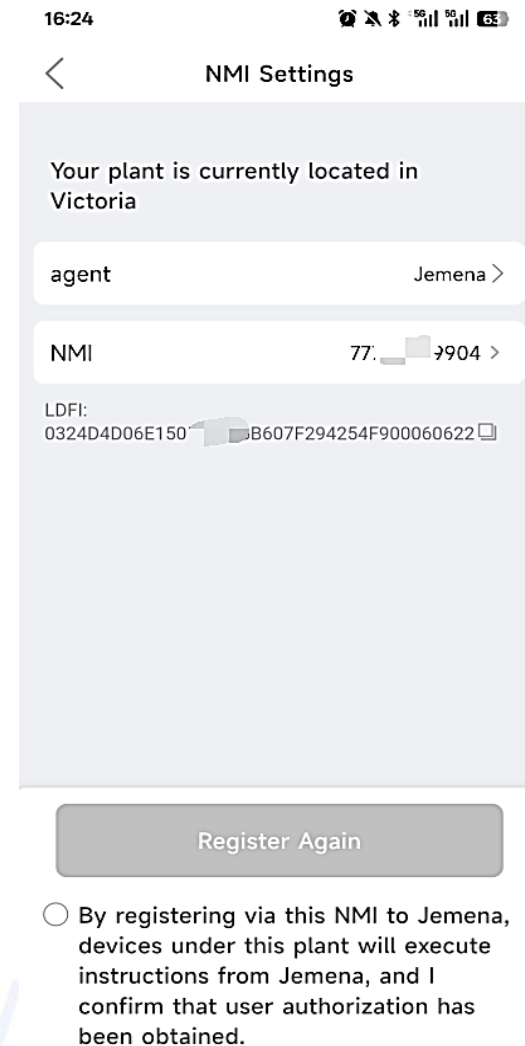

16:24

< NMI Settings

Your plant is currently located in Victoria

agent Jemena >

NMI 77. [redacted] 9904 >

LDFI:  
0324D4D06E150 [redacted] B607F294254F900060622 [copy icon]

Register Again

By registering via this NMI to Jemena, devices under this plant will execute instructions from Jemena, and I confirm that user authorization has been obtained.

# | CONTENTS

• 01  
Program Overview

• 02  
Installation

• 03  
App Configuration

• 04  
FAQ

# Common Alarms and Troubleshooting Suggestions

Common Alarms	Troubleshooting
Meter Communication Fault Alarm	<ol style="list-style-type: none"><li>1. Verify that the electricity meter is connected.</li><li>2. Ensure the meter communication cable is properly connected and not loose.</li><li>3. If the issue persists after checking the above, please contact Hyxipower customer service.</li></ol>
Ground Fault	<ol style="list-style-type: none"><li>1. Verify that the AC cables are connected with the correct phase sequence.</li><li>2. Ensure that the insulation between the ground wire and the live wire is intact.</li><li>3. If the issue persists after checking the above, please contact Hyxipower Customer Service Center.</li></ol>
PV Instantaneous Overcurrent	<ol style="list-style-type: none"><li>1. Try restarting the inverter by cycling power.</li><li>2. If the issue persists after checking the above, please contact Hyxipower customer service.</li></ol>
PV1 Instantaneous Overvoltage	<ol style="list-style-type: none"><li>1. Try restarting the inverter by cycling power.</li><li>2. If the issue persists after checking the above, please contact Hyxipower customer service.</li></ol>
PV Polarity Reverse Fault	<ol style="list-style-type: none"><li>1. Verify the polarity of the PV input connections. If reverse polarity is detected, reconnect correctly.</li><li>2. If all the above are normal and the fault remains, please contact Hxipower customer service.</li></ol>
Grid Overvoltage	<p>The unit will normally reconnect to the grid once grid conditions return to normal.</p> <ol style="list-style-type: none"><li>1. Measure the actual grid voltage. If it exceeds the set value, contact the power company.</li><li>2. Check the inverter protection settings.</li><li>3. If grid voltage is normal, verify that AC wiring is securely connected.</li><li>4. If the issue persists after checking the above, contact Hxipower customer service.</li></ol>
Battery Voltage Overvoltage	Verify the battery overvoltage setting. If the setting is correct and the fault remains, contact Hyxipower customer service.
Battery Voltage Undervoltage	Wait for fault recovery and restart. If the issue recurs, restart the unit. If the fault remains, contact Hyxipower customer service.
Grid Certification Overvoltage Fault	Clear the fault in accordance with the applicable standards of each country.
Grid Certification Undervoltage Fault	Clear the fault in accordance with the applicable standards of each country.

# FAQ

Q: For DC Couple parallel systems, is it mandatory to maintain identical photovoltaic array power configuration between the two inverters?

A: Power consistency must be maintained; it is not permissible to have one unit installed and the other not.

Q: During the installation of AC Couple, can CT1 and CT2 be interchanged?

A: No, interchanging them would cause data errors in the energy flow diagram.

Q: Can the CT direction of a third-party inverter be corrected remotely?

A: No, currently we only support remote correction for bus CT direction errors.

Q: Can the battery communication cable be connected at either end?

A: No, the battery communication cable must be connected in the specified order: the connector labeled "3/4BAT" must be attached to the battery, and the connector labeled "4/5INV" must be connected to the inverter. Reversing this sequence will cause a battery communication failure.

Q: Can the emergency stop switch on the right side of the BDU be directly opened after the battery is powered on?

A: No, this operation may potentially damage the inverter.

# 智慧能源 人人共享

Smarter Energy for All

