



HYXI



User Manual

iEMS SMART MANAGEMENT SYSTEM

HYX-iEMS2.0



Carefully read this user manual before using the product.
Read and save these instructions.



© **ZHEJIANG HYXI TECHNOLOGY CO., LTD. All rights reserved.**

This document cannot be copied fully or partially, transferred, or distributed in any form without the prior written permission of ZHEJIANG HYXI TECHNOLOGY CO., LTD (hereinafter referred to as "HYXI").

TRADEMARKS



and other HYXI trademarks are the trademarks or registered trademarks of HYXI All other trademarks mentioned herein are the properties of their respective owners.

Contents

About this Manual	1
Overview	1
Scope of Application	1
For Readers	1
Use of the Manual.....	1
Use of Symbols	2
1 Product Overview	3
2 System Requirements	3
2.1 Software Requirements	3
2.2 Hardware Requirements	3
3 System Overview	4
3.1 Logical Topology	4
3.2 Interfaces Description	5
3.3 Functions Description.....	6
3.3.1 Main Functions of the iEMS System.....	6
3.3.2 Function of Components.....	7
3.4 System Startup	7
4 Operating Instructions	8
4.1 User Management.....	8
4.1.1 Log into the System.....	8
4.1.2 Account System Management.....	10
4.1.3 Log Out of the System.....	13
4.1.4 User Permissions Overview.....	13
4.2 Device Management	14
4.3 System Topology Diagram	14
4.4 Energy Storage System.....	15
4.5 Strategy Management.....	16
4.6 Environmental Monitoring	24
4.7 Report Management	26
4.8 Alarm Management	33
4.9 Operation Log	33
4.10 Upgrade and Maintenance.....	35
4.11 Electricity Price Management.....	36
5 Maintenance & Precautions.....	38
6 Contact Information.....	39

About this Manual

This manual describes HYXI iEMS Smart Energy Management System in terms of features, product overview, and operation instructions.

Overview

To ensure the proper installation and use of the product and its superior performance, before installation and operation of the product, please read the operating instructions in detail and follow all safety precautions in the instructions.

Scope of Application

This manual is intended for the following device:

- HYX-iEMS2.0

For Readers

This manual is intended for professional technicians who need to operate the product.

All installation operations must be carried out by professional technicians and only by professional technicians.

Use of the Manual

Please read the manual carefully before using the product, the content of the manual will be updated and corrected, but it is inevitable that there is a slight discrepancy or error with the actual product. Users should refer to the actual product purchased and obtain the latest version of the manual by downloading from www.hyxipower.com or through sales channels.

The latest version of the manual is available for download at or through sales channels.

Use of Symbols

To ensure user safety and property protection during product use, relevant information is provided and highlighted with the following symbols.

DANGER

- Indicates a high potential hazard that, if not avoided, could result in death or serious injury.

CAUTION

- Indicates a low potential hazard which, if not avoided, could result in moderate or minor injury.

NOTICE

- Indicates a potential risk which, if not avoided, could result in the equipment not functioning properly or in property damage.

1 Product Overview

This manual provides a detailed description of the features of the iEMS Smart Energy Management System and explains how to operate each functional module.

2 System Requirements

2.1 Software Requirements

Operating system: Linux Ubuntu 20.0

2.2 Hardware Requirements

CPU requirement: 1.8 GHz quad-core ARM architecture

Memory requirement: 32GB eMMC + 4GB DDR3.

Storage requirement: 250GB SSD (optional 512GB/1TB)

Communication requirement : 4G / Wi-Fi / LAN*1, WAN*1

3 System Overview

3.1 Logical Topology

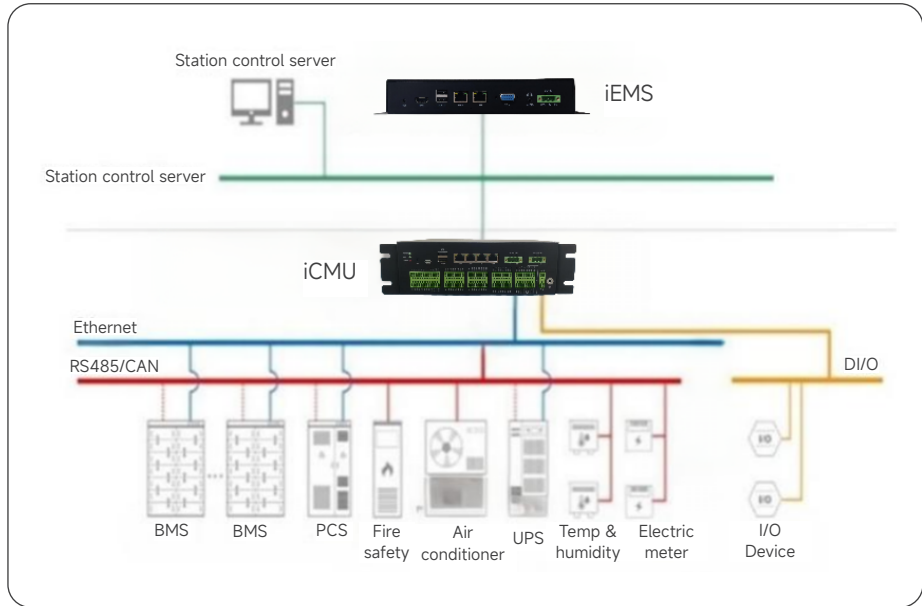

3.2 Interfaces Description

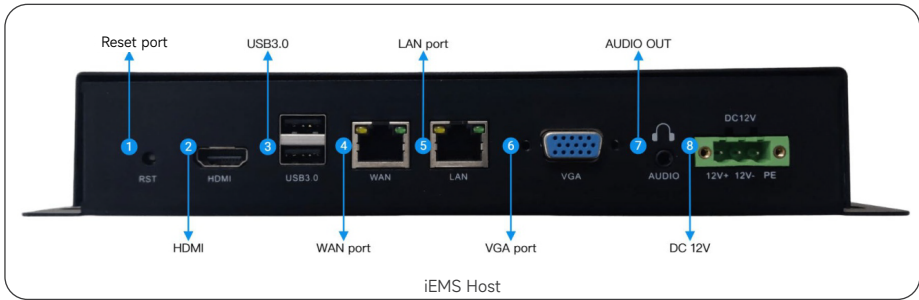

No.	Interface	Description
1	Reset port	Reset the device
2	HDMI	HDMI port
3	USB3.0	2 USB 3.0 ports for update or file transfer
4	WAN port	1 WAN port, for connecting to the internet
5	LAN port	1 LAN port, for local area network connection between devices
6	VGA port	1 VGA port, for connecting to an external display
7	AUDIO OUT	1 audio output port, supports 3.5mm jack connection
8	DC 12V	DC 12V power supply port

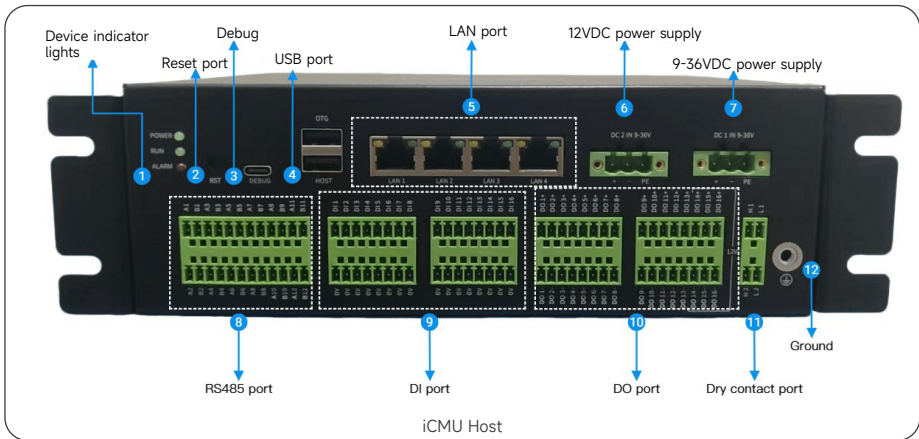

No.	Interface	Description
1	Device indicator lights	POWER: Power indicator RUN: Device operation indicator ALARM: Alarm indicator
2	Reset port	Reset the device
3	Debug	Device local upgrade and maintenance interface
4	USB port	Data transfer, mobile device interface

No.	Interface	Description
5	LAN Port	For communication between secondary units
6	12VDC power supply	Device power supply interface, supports 12 VDC
7	9-36VDC power supply	Device power supply interface, supports 9-36 VDC
8	RS485 port	12-channel RS485 ports for connecting to external device
9	DI port	16-channel DI ports for connecting digital signals from external devices
10	DO port	16 DO ports, including 3 with 12V active interfaces, for connecting to external digital outputs
11	Dry contact port	For dry contact protection
12	Ground	Device grounding connection point

3.3 Functions Description

3.3.1 Main Functions of the iEMS System

The main functions of the iEMS Smart Energy Management System include:

- Real-time data visualization (tables, bar charts, graphs, etc.)
- Display of the system deployment schematic diagram
- Historical data display (tables, graphs, etc.)
- Alarm notification and query
- Functional control (grid-connected operation, power control, manual/automatic control, etc.)
- Logical protection (battery protection, anti-reverse control, demand control, etc.)

3.3.2 Function of Components

The iEMS Smart Energy Management System consists of the following components: User Management, Device List, Status Filtering, System Alarm, System Event, System Report, Monitoring List, System Log, Real-time Data, Historical Data, System Deployment Schematic Diagram, and Real-time Alarm Monitoring Alert.

No.	Item	Description
1	System Monitoring Main Page	Comprehensive monitoring of the energy storage system
2	User Management	Manage user logins and logouts
3	Device List	Select the node to view based on the navigation tree
4	Status Filtering	Filter by status to display nodes that meet the criteria
5	System Alarm	Real-time system alarm based on the selected filter criteria
6	System event	System event information based on the selected filter criteria
7	Monitoring list	Select the pages to monitor
8	System log	System log information based on the selected filter criteria
9	System report	Display system report information
10	Real-time data	Real-time display shows various real-time data, including device lists and cell lists
11	Historical data	Provides access to historical alerts, historical events, and historical data trends
12	System Deployment Schematic Diagram	Display system deployment schematic diagram
13	Real-time Alarm Monitoring Alert	Monitor alarm status and display alerts when alarms occur

3.4 System Startup

Power on the device. Then ensure that the PC and the iEMS's WAN port are connected to the same network. Open a web browser, enter the address <http://192.168.101.1> , and log in.

4 Operating Instructions

4.1 User Management

4.1.1 Log into the System

Step 1: Connect your PC to the same network as the iEMS's WAN port.

Open a web browser (Firefox or Google Chrome is recommended) and enter the IP address: <http://192.168.101.1>, to log in.

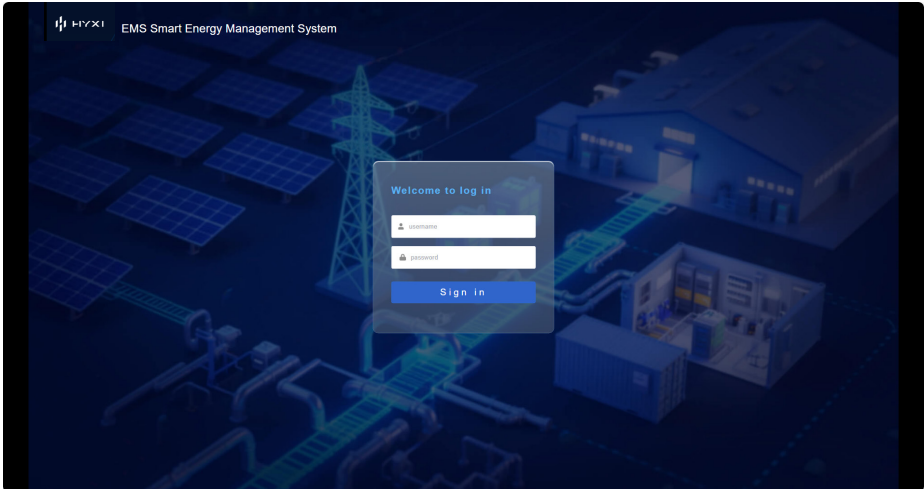

Step 2: On the login page, enter your "Username" and "Password". The default username is [admin], and the default password is [admin123]. Click **Login** to access the system's main page (as shown below).

The system is designed to determine the user's operation type based on the logged-in user. The user's access permissions are determined by their operation type, and the system retrieves the user's corresponding project information from the database based on the user's identity. The system's main page is shown below.



At the top of the system's main page:

Left: Displays the company logo (which can be changed in Site Management) and the language switch button (currently supports switching between Chinese and English);

Center: Displays the site name;

Right: Displays device time, System Management (navigation button), and Account Information (navigation button).

Left Navigation Bar:

Top-left:

System Status: Displays the system's design capacity, current chargeable capacity, and current dischargeable capacity;

System On-Grid /Off-Grid Status: On-Grid /Off-Grid;

System Operating Status: Idle/Shutdown/Running;

System Operating Mode: Automatic/Manual/Third-Party Management.

Charge/Discharge Capacity: Displays charge/discharge energy for the past 7 days, the settings button allows quick navigation to the charge/discharge statistics page.

Bottom-left:

Real-time Power: Displays real-time power for today, covering energy storage, loads, PV, EV charger, etc.; the settings button allows quick navigation to the real-time power query window.

Right Navigation Bar:

Top-Right:

Overview of Dynamic Ring: Directly view the power plant 's minimum cell temperature, maximum cell temperature, liquid cooling unit operating status, entrance guard status, ambient temperature and humidity. The settings button provides quick access to the environmental monitoring management interface.

Center Right:

Site Overview: Displays site photos. The settings button allows quick navigation to the site information management page.

Bottom-Right:

Alarm Information: This window displays real-time alarm information (level 2 and above are displayed here; level 3 alarms trigger an additional pop-up window). The settings button allows quick navigation to the alarm management page.

The center of the main page: displays System Topology Diagram, with the site's operational and charging status shown below.

4.1.2 Account System Management

Access Account System Management via the **Account Information** navigation bar to manage Personal Information, Account Management, System (Site) Configuration, and Network Setting.

Personal Information: You can set your user name, account name (customizable), bind a mobile number, bind an email address, and change your password. After editing the information, click **Save** to complete the settings, as shown in the figure below:

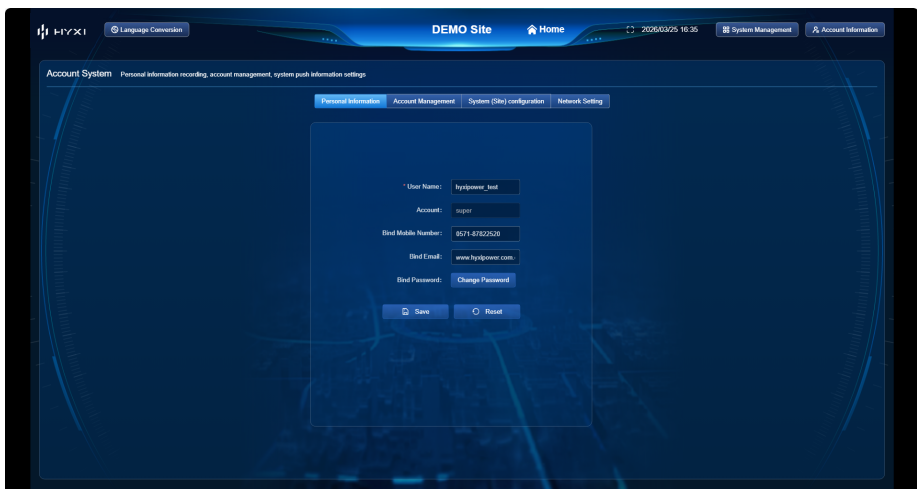

Account Management: Manage accounts under your authority, including adding, deleting, and maintaining account information;

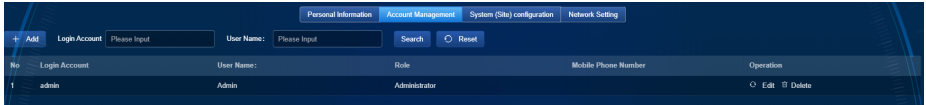

Click **Add** to open the detailed account information settings:

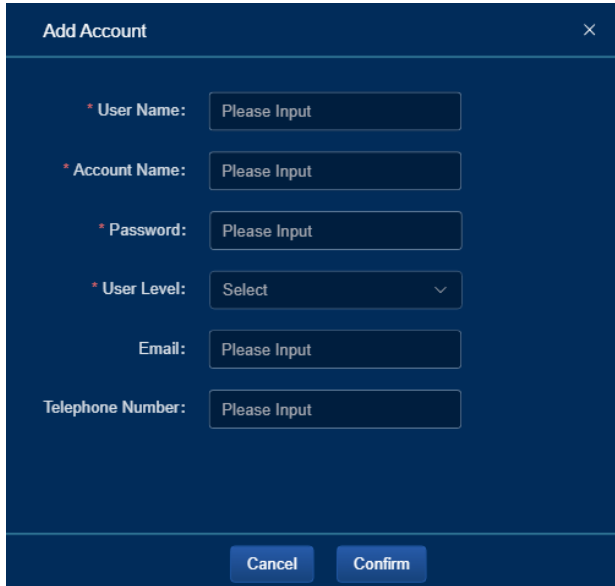
A screenshot of the 'Add Account' form. The form has a title 'Add Account' and a close button 'X'. It contains several input fields: 'User Name' (required, marked with an asterisk), 'Account Name' (required, marked with an asterisk), 'Password' (required, marked with an asterisk), 'User Level' (required, marked with an asterisk, with a dropdown menu showing 'Select'), 'Email', and 'Telephone Number'. Each field contains the placeholder text 'Please Input'. At the bottom of the form, there are two buttons: 'Cancel' and 'Confirm'.

System (Site) Configuration: Access the system site configuration to manage the site name, the site's actual geographic location, and alert notification levels/intervals. After editing the information, click **Save** to complete the update.

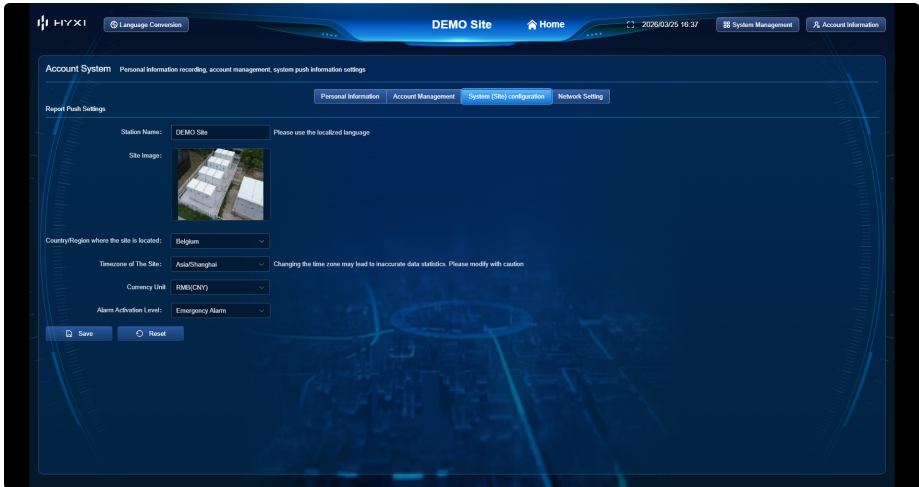

Network Settings: On the Network Settings subpage, you can configure settings for local networks, 4G, and other network types.

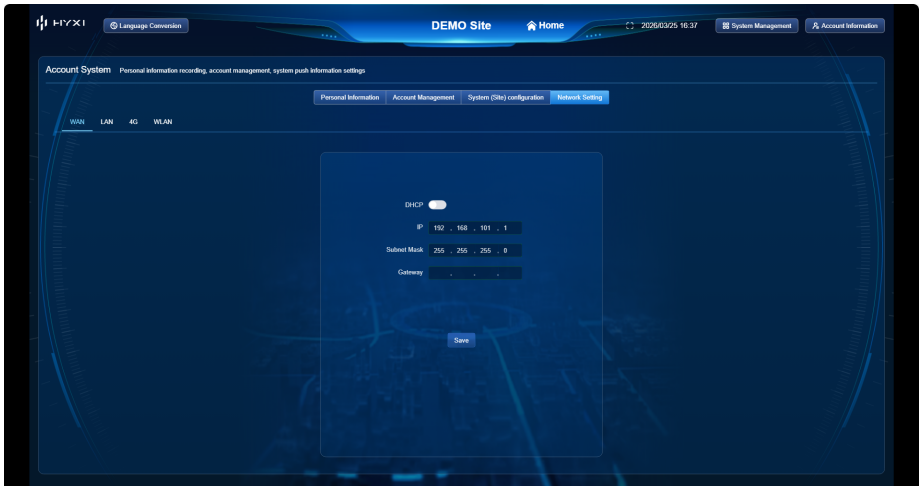

4.1.3 Log Out of the System

After logging in, move the mouse cursor over the account information menu in the top-right corner and click **Log Out** to exit the system and return to the previous login page.



4.1.4 User Permissions Overview

There are three user types: Super Administrator, Administrator, and Visitor.

Super Administrator: Monitors and views platform operational data; has permissions to issue commands, view system logs, and access the data overview database; also has permissions for system configuration and debugging (can add or remove Administrator and Visitor accounts).

Administrator: Monitors and views platform operational data; has the authority to issue commands and view system logs (can add or remove visitor accounts).

Visitor: Has permission only to monitor and view platform operational data.

4.2 Device Management

To add a device, click **Device Management** in the System Management navigation menu at the top-right. This allows you to add or remove external devices. After clicking **Save**, the added devices will appear in the "Device Tree" section on the left side of the management page.

When the main interface appears, you can select Device Configuration, DIDO Template, or Device Configuration Template from the secondary navigation bar to access different sub-interfaces.

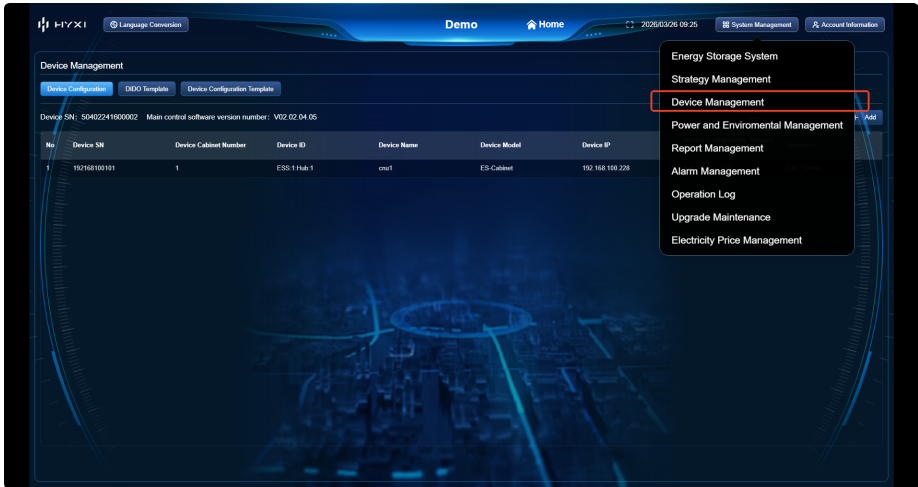

4.3 System Topology Diagram

The center of the home page displays System Topology Diagram for the project, and detailed information about communication lines.

You can view the voltage, current, power supply, as shown in the figure below:



4.4 Energy Storage System

Select **System Management > Energy Storage System** to choose different subsystems from the secondary navigation menu. You can view the operational status, environmental monitoring data, PCS operational status, and alarm information for each cabinet, as shown in the figure below:

This page displays the overall summary information for the energy storage station. You can click the **Home** button to return directly to the main page.



4.5 Strategy Management

Work Mode and Strategy Settings

Click **System Management** to enter the Strategy Management page, here you can configure various operating modes for the entire power station. There are three main modes: Manual Mode, Automatic Mode, and Platform Dispatch. The information page is shown below:



The secondary navigation on the subpage displays the current operating mode, active strategy, grid status, and operational status; it also shows the current location information, as shown in the figure below:

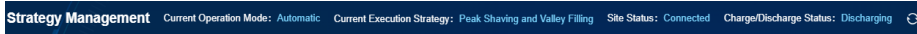

【 Manual Mode 】: It consists of power on/off buttons, grid-connected/off-grid buttons, and a power dispatch box. It is used for manual operation of device and debugging scenarios. As shown in the figure below:



[Automatic Mode] : In automatic mode, you can configure strategy templates, strategy types, and operational strategies. Within the strategy templates, time-based operational strategies— as shown in the figure below—you can set charging, discharging, and standby strategies for different time periods;

(1) Add Strategy:

[Automatic Mode] : Click the + button to add a strategy.

[Strategy Name] : You can customize the name based on the strategy’s specifics.

[Priority] : Priority levels are **1** to **15**, with Level 1 being the highest.

[Execution Cycle] : Options include **Weekly**, **Daily**, and **Long-term**.

[Strategy Template] : You can select content from pre-configured "Strategy Templates".

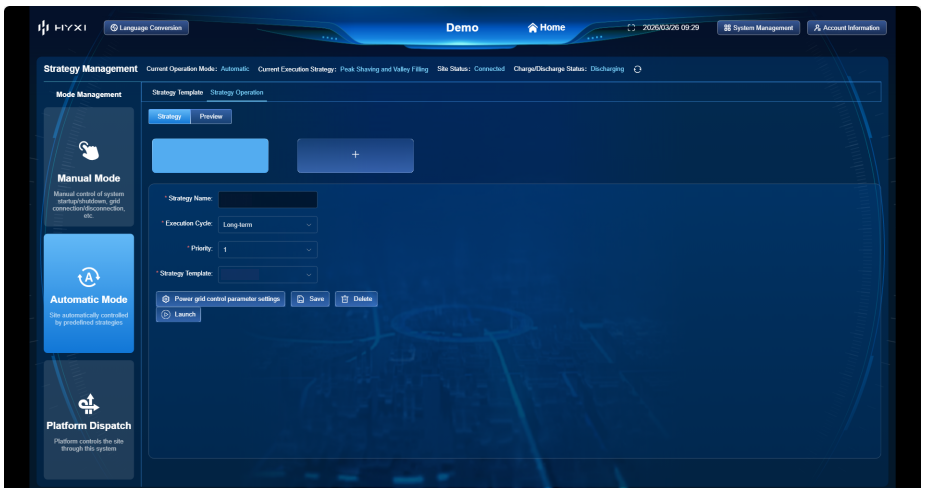

【 Power grid control parameter settings 】 The settings include anti-backflow parameters and demand control parameters. All work modes will operate within the constraints of Anti-backflow parameters and demand control parameters.

Anti-backflow Parameters:

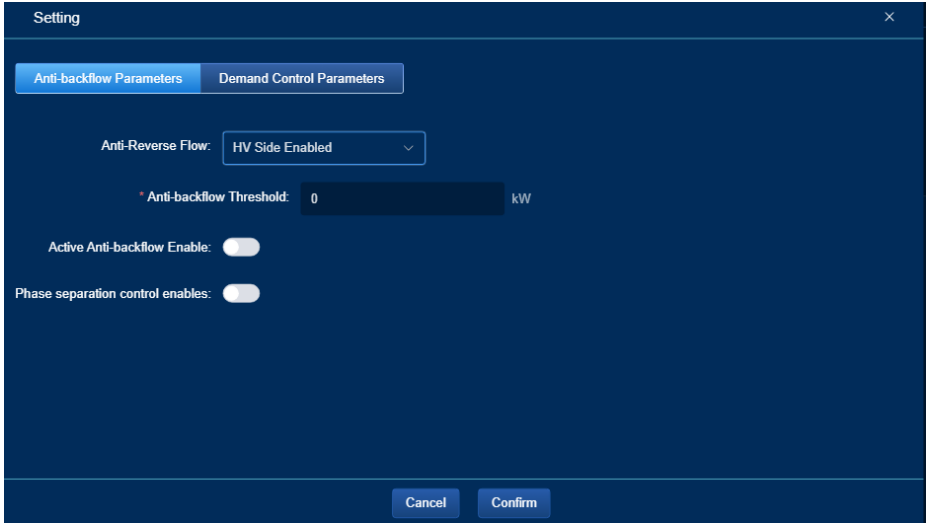

Strategy Name	Strategy Parameters	Setting Description
Anti-backflow	Anti-Reverse Flow	Select the appropriate strategy type based on the connection configuration of the grid meter. You can select Disable , HV Side Enabled , and LV Side Enabled .
	Anti-backflow threshold	Target power for Anti-backflow
	Active Anti-backflow Enable	When this setting is enabled, the system will switch to charging mode when the conditions are met.
	Phase separation control enables	When this setting is enabled, the system will be controlled separately for each phase based on its power.

Demand Control Parameters:

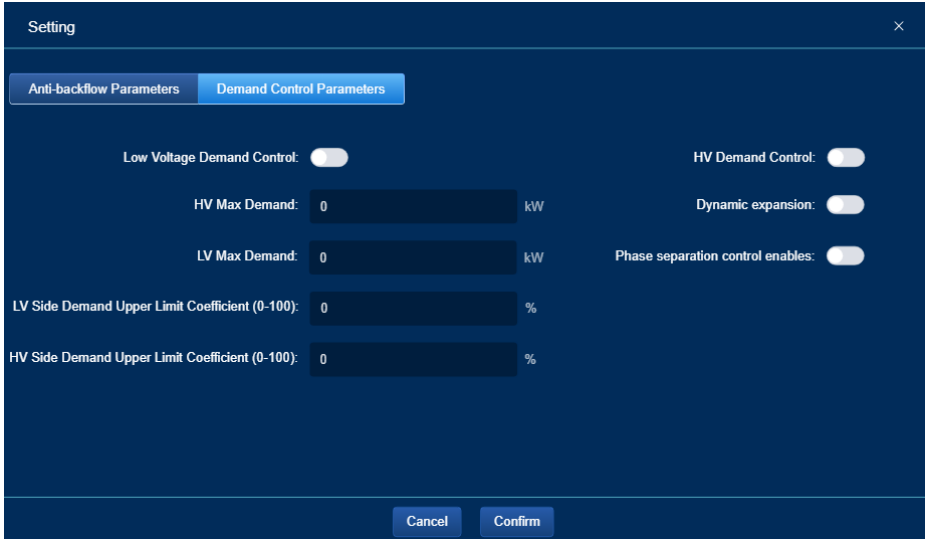

Strategy Name	Strategy Parameters	Setting Description
Demand Control Parameters	Demand control type	Select the appropriate strategy type based on the connection configuration of the grid meter. You can select, HV Demand Control, LV Demand Control.
	Max Demand	Maximum transformer capacity
	Demand Upper Limit Coefficient	Conversion factors for demand control targets. Target power = Max Demand X Demand Upper Limit Coefficient
	Dynamic expansion	When this setting is enabled, the system will switch to discharging mode when the conditions are met.
	Phase separation control enables	When this setting is enabled, the system will be controlled separately for each phase based on its power.

(2) Add Template:

Peak Shaving and Valley Filling

Step 1: In the Basic Parameters section, enter the template name in the "Template Name" field. Starting at 0:00, set the start and end times, configure the relevant energy storage operations, and specify the execution power. A charging and discharging strategy covering 0–24 hours must be set.



Example: Consider a commercial and industrial energy storage system consisting of one unit with a total power of 125 kW, operating under a time-of-use strategy (24-hour operation)

Start Time	End Time	Control Type	Planned Power (kW)
00:00	05:00	Charging	40
05:00	08:00	Standby	0
08:00	11:00	Discharging	50
11:00	13:00	Charging	50
13:00	13:30	Standby	0
13:30	18:00	Discharging	50
18:00	24:00	Standby	0

Step 2: Set strategy parameters, including the maximum and minimum cell voltage thresholds, temperature upper limit, SOC upper limit and SOC lower limit.

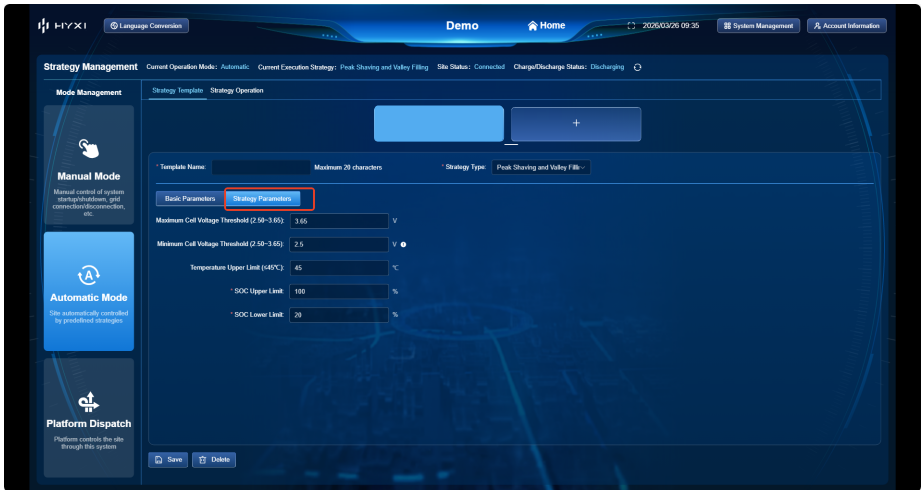

Strategy Name	Parameters	Setting Description
Strategy Parameters	Maximum and minimum cell voltage thresholds	Protection parameters for cell voltage: device will shut down if the maximum cell voltage exceeds the set value or the minimum cell voltage falls below the set value.
	Temperature upper limit	Protection parameters for cell temperature: device will shut down if the maximum cell temperature exceeds the set value.
	SOC upper limit (%)	Protection parameters for battery SOC: device will shut down if SOC exceeds the set value.
	SOC lower limit (%)	Protection parameters for battery SOC: device will shut down if SOC below the set value.

NOTICE

- Please contact the manufacturer’s technical staff for guidance on setting strategy parameters.

Step 3: Click **Save**.

Step 4: After configuring the strategy, you can click **Preview** to preview the set strategy:

The screenshot displays the 'Strategy Management' interface. At the top, it shows 'Language Conversion', 'Demo', 'Home', the date '2026/03/26 09:36', and 'System Management' and 'Account Information' buttons. The main area is titled 'Strategy Management' and includes 'Current Operation Mode: Automatic', 'Current Execution Strategy: Peak Shaving and Valley Filling', 'Site Status: Connected', and 'Charge/Discharge Status: Discharging'. On the left, there are three mode options: 'Manual Mode' (Manual control of system configurations, and connection/disconnection, etc.), 'Automatic Mode' (Site automatically controlled by predefined strategies), and 'Platform Dispatch' (Platform controls the site through this system). The central part shows a calendar for '2026-03-26' with a 'Preview' button. The calendar grid shows days from Sun to Sat, with the 26th highlighted. On the right, a 'Details' section shows a bar chart and a table of time slots with their corresponding status and planned power.

Time Slot	Status	Planned Power
09:00-05:00	Charging	Planned Power: 40
05:00-08:00	Standby	Planned Power: 0
08:00-11:00	Discharging	Planned Power: 50
11:00-13:00	Charging	Planned Power: 50
13:00-13:30	Standby	Planned Power: 0
13:30-18:00	Discharging	Planned Power: 50
18:00-24:00	Standby	Planned Power: 0

Self-consumption

The setting steps for other policy types are similar to those for Peak Shaving and Valley Filling; here only describe the parameter settings specific to this policy type.

* Template Name: Maximum 20 characters

* Strategy Type:

Basic Parameters | Strategy Parameters

Adjust Dead Zone: kW

Adjust Power: kW

Adjust Time Interval: s

Work Mode	Parameters	Description
Self-consumption	Adjust dead zone	To avoid frequent adjustments caused by fluctuations in load power, the range of values for grid connection point power regulation is: [Adjust power – tracking dead zone /2, Adjust power+ tracking dead zone /2]
	Adjust power	The target of grid consumption power is set by the system; the EMS adjusts the energy storage output to maintain the power at the grid connection point at the set value.
	Adjust time interval	Interval for adjusting self-consumption power

Full Feed-in

The setting steps for other policy types are similar to those for Peak Shaving and Valley Filling; here only describe the parameter settings specific to this policy type.

* Template Name: Maximum 20 characters

* Strategy Type:

Basic Parameters | Strategy Parameters

Power: kW

Work Mode	Parameters	Description
Full Feed-in	Adjust Power	The target of grid feed-in power is set by the system; the EMS adjusts the energy storage output to maintain the power at the grid connection point at the set value.

Backup Mode

The setting steps for other policy types are similar to those for Peak Shaving and Valley Filling; here only describe the parameter settings specific to this policy type.

* Template Name: Maximum 20 characters

* Strategy Type:

Basic Parameters Strategy Parameters

SOC Value: % The power limit for charging from the grid: kW

Work Mode	Parameters	Description
Backup Mode	SOC Value	The target SOC for the energy storage backup, if the SOC falls below the target, forced charging will be initiated.
	The power limit for charging from grid	Upper limit on the grid charging power during forced charging.

4.6 Environmental Monitoring

The Environmental Monitoring page displays real-time status information for environmental monitoring devices such as liquid cooling units, fire protection systems, molded case circuit breakers, access control systems, water sensors, SPD, and temperature & humidity sensors, including quick control functions for liquid cooling units. As shown in the figure below:



In the sub-navigation page, you can select the environmental monitoring status of different cabinets within the power station. As shown in the figure below:

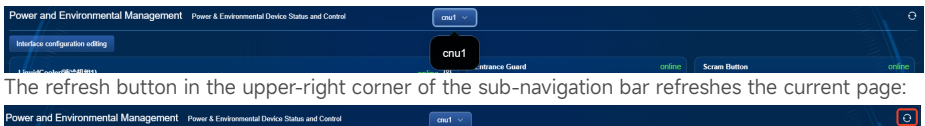

The refresh button in the upper-right corner of the sub-navigation bar refreshes the current page:

The liquid cooling unit sub-window displays the real-time status of the liquid cooling unit in the current cabinet. You can access the command issuance page by clicking the settings button on the right, as shown in the figure below:

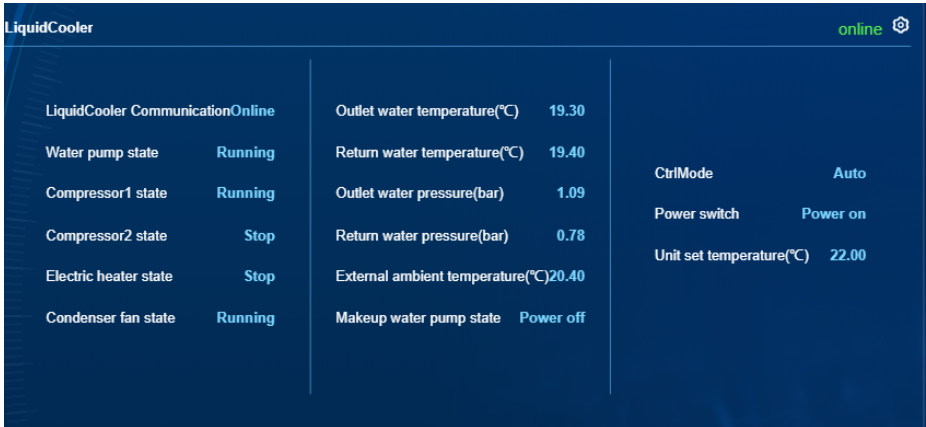

Liquid Cooling Unit Command Dispatch Window: Here you can change the control mode, temperature, and manually start or stop the liquid cooling unit. As shown in the figure below:

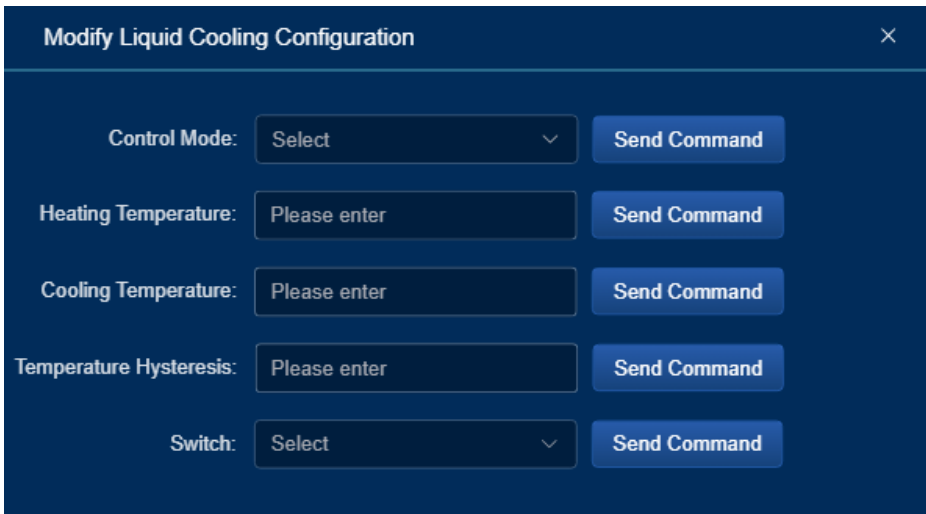

4.7 Report Management

The Report Management page includes the following functions: Electricity Statistics (Monthly, Annual), Revenue Statistics (Monthly, Annual), Alarm Record Reports, Main Equipment Parameter Tables, Data Overview Database (visible to administrator accounts), Task List, Export, as shown in the figure below:

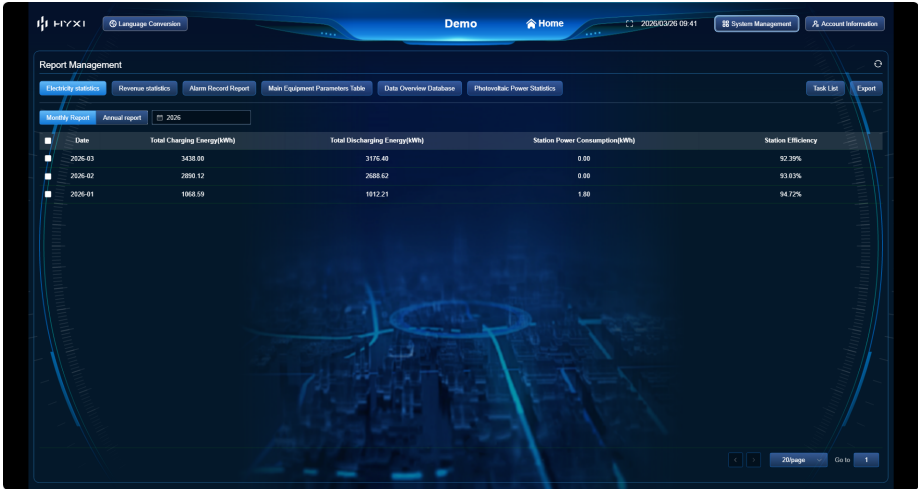

For Electricity Statistics (Revenue Statistics), select a report on the subpage and click to view details, as shown in the figure below:

DemoMonthly report on power generation statistics

Time	Charging Capacity(kWh)						Discharging Capacity(kWh)						Station Efficiency	Station Power Consumption(MWh)
	Sharp	Peak	Flat	Valley	Deep Valley	Total	Sharp	Peak	Flat	Valley	Deep Valley	Total		
2026-03-01	0.00	0.00	0.00	223.21	0.00	223.21	0.00	205.20	0.60	0.00	0.00	205.80	92.20%	0.00
2026-03-02	0.00	0.00	0.00	206.40	0.00	206.40	0.00	189.61	0.59	0.00	0.00	190.20	92.15%	0.00
2026-03-03	0.00	0.00	0.00	151.20	0.00	151.20	0.00	88.81	0.60	0.00	0.00	89.41	59.13%	0.00
2026-03-04	0.00	0.00	0.00	0.00	0.00	0.00	0.00	0.59	0.60	0.00	0.00	1.19	—	0.00
2026-03-05	0.00	0.00	0.00	0.00	0.00	0.00	0.00	0.60	0.00	0.60	0.00	1.20	—	0.00
2026-03-06	0.00	0.00	0.00	0.00	0.00	0.00	0.00	0.00	0.60	1.20	0.00	1.80	—	0.00
2026-03-07	0.00	0.00	0.00	0.00	0.00	0.00	0.00	0.00	0.60	0.60	0.00	1.20	—	0.00
2026-03-08	0.00	0.00	0.00	0.00	0.00	0.00	0.00	0.60	0.00	0.60	0.00	1.20	—	0.00
2026-03-09	0.00	0.00	0.00	0.00	0.00	0.00	0.00	0.60	0.60	0.60	0.00	1.80	—	0.00
2026-03-10	0.00	0.00	0.00	0.00	0.00	0.00	0.00	1.80	31.80	0.60	0.00	34.20	—	0.00
2026-03-11	0.00	0.00	0.00	193.80	0.00	193.80	0.00	190.80	0.60	0.00	0.00	191.40	98.76%	0.00

For the export function, select report on the report page and click "Export." This will generate an export task in the task list. Locate the corresponding task to complete the download, as shown in the figure below:

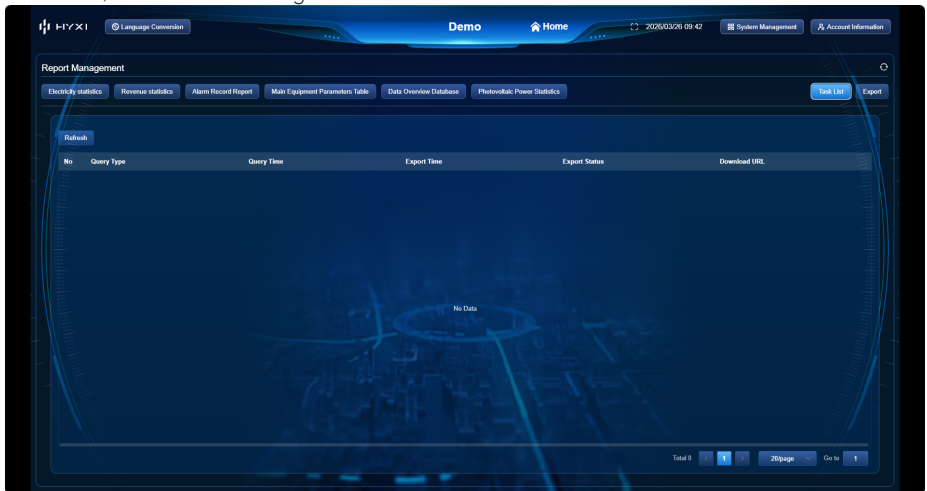

Alarm Record Report: Here you can view current real-time alarm information and historical alarm information, as shown in the figure below:

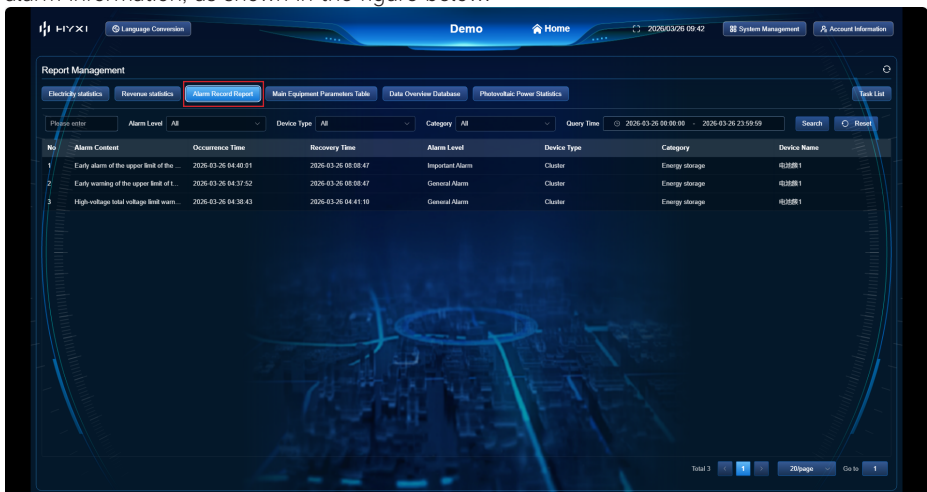

To view alerts by time period, click the time bar shown in the figure below to select a time range, then click the **Search** button to complete the search, as shown in the figure below:

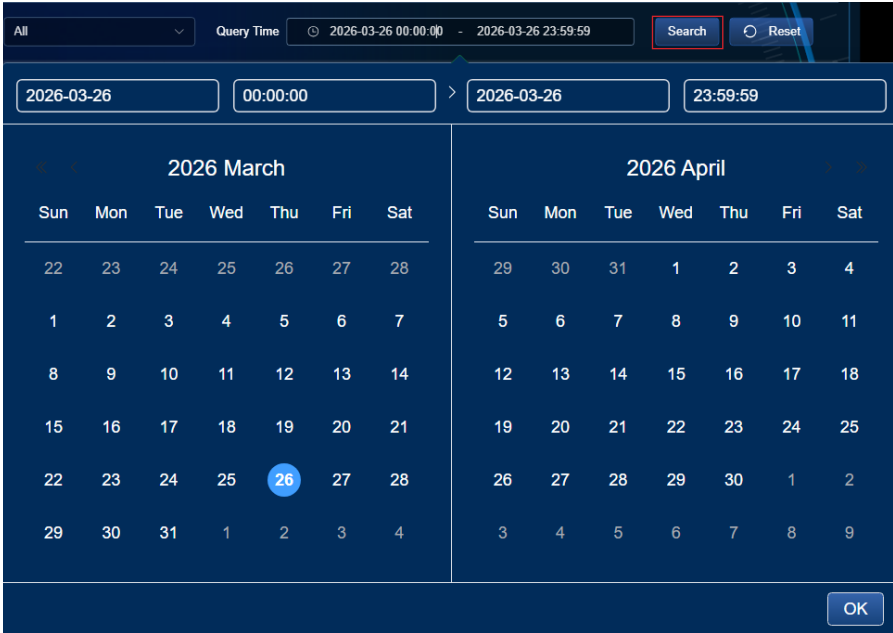

Alarm Level: Here you can select the following alarm levels, as shown in the figure below:

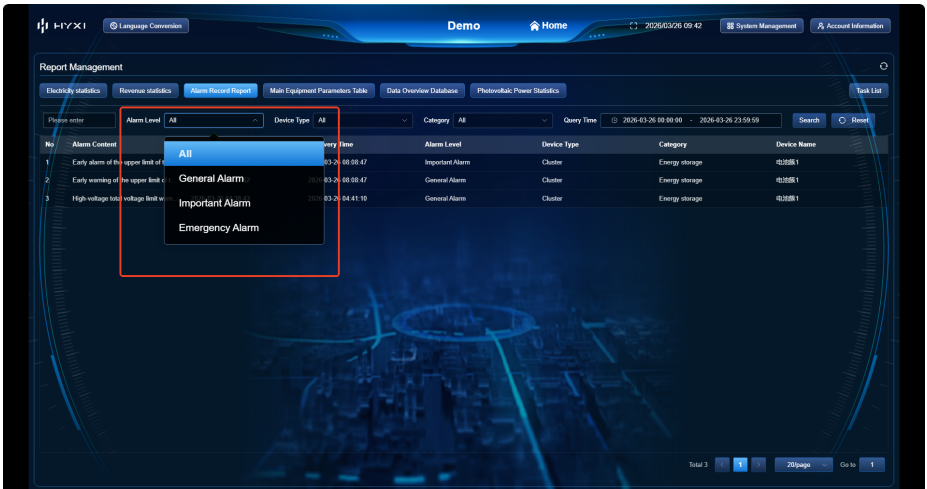

Device Type: Here you can select the following device types, as shown in the figure below:

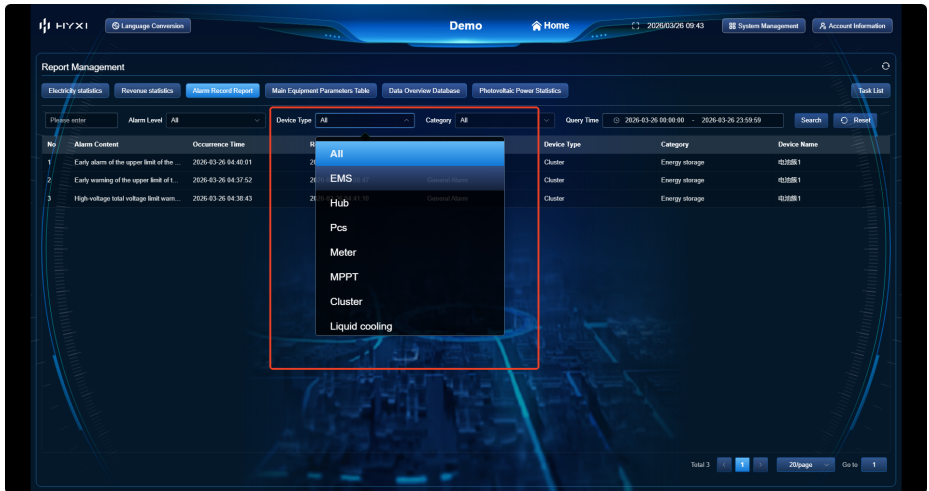

Category: Here you can select the following alarm categories, as shown in the figure below:

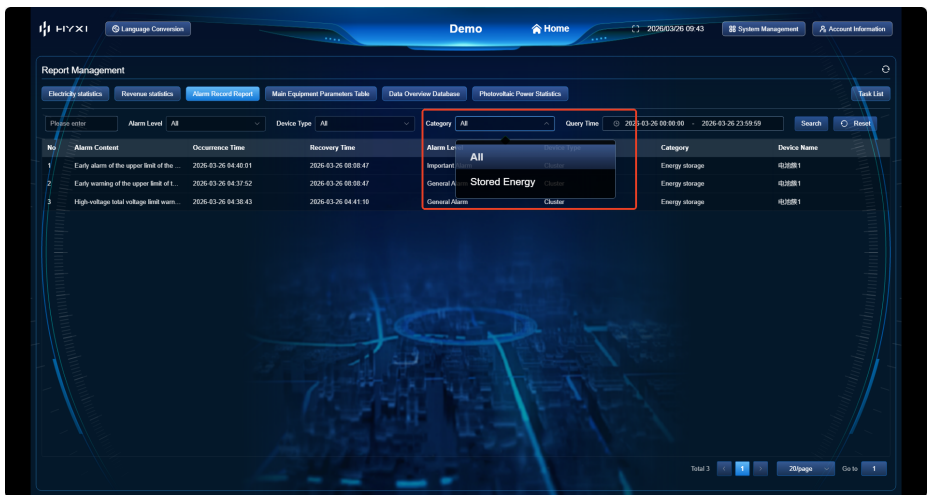

Main Equipment Parameters Table: It displays parameter information for the main equipment within the energy storage cabinet at the current site, including: device type, model /specifications, main parameters, version, manufacturer, remarks, etc., as shown in the figure below:

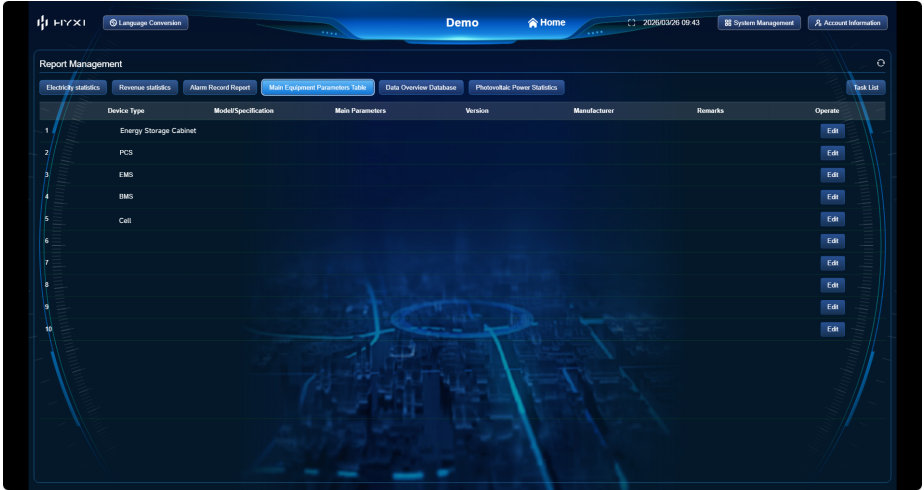

Data Overview Database: Visible to administrator accounts; not visible to visitors or accounts with lower-level permissions. Primarily used for querying real-time and historical data for all devices. To access subpages, select the query type (real-time/historical) in the first search bar, as shown below:

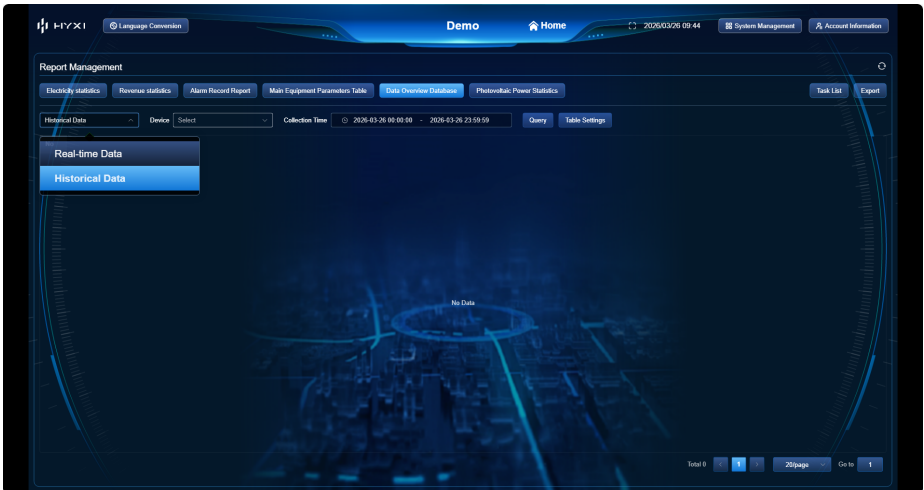

Real-Time Data Query: Select the cabinet you want to view from **Device**, then click **Query** to access the database:



Real-Time Data Query for PACK:





Historical Data Query:

The screenshot shows the 'Historical Data' query results. The table contains the following data:

No.	Callcut on time	Commitment status	Work status	Charging and discharging status	Active power	Reactive power	Apparent power	The phase current of the communication side	The phase current of the communication side	C phase current of the communication side	The phase voltage of the communication side	The phase voltage of the communication side	The voltage of phase C on the communication side	Communication power factor	Communication side AB phase II voltage	Communication side BC phase II voltage	Communication side CA phase II voltage	The active power of phase A	Active power of phase B in communication	The active power of phase C in communication	Communication A reverse power	Communication B reverse power
1	2026-03-26 00:00:00	1	3	2	1	49.7	-1.5	49.9	72.9	73.7	73	226.5	228.1	227.3	0.995	0	0	16.4	16.7	16.5	-0.5	-0.3
2	2026-03-26 00:00:00	1	3	2	1	49.7	-1.4	49.9	72.9	73.6	73.1	226.3	228.5	227	0.995	0	0	16.4	16.7	16.5	-0.4	-0.4
3	2026-03-26 00:00:00	1	3	2	1	49.7	-1.4	49.9	73	73.7	72.9	226.6	228.3	227.6	0.995	0	0	16.4	16.7	16.5	-0.4	-0.3
4	2026-03-26 00:00:00	1	3	2	1	49.7	-1.4	49.9	73	73.7	73.1	226.1	227.8	227.3	0.995	0	0	16.4	16.7	16.5	-0.5	-0.3
5	2026-03-26 00:00:00	1	3	2	1	49.7	-1.3	50	73.1	73.6	72.8	225.9	228.5	227.8	0.995	0	0	16.4	16.7	16.5	-0.4	-0.3
6	2026-03-26 00:00:00	1	3	2	1	49.8	-1.4	50	73.1	73.9	73.3	225.9	227.6	227.6	0.995	0	0	16.4	16.8	16.5	-0.5	-0.4
7	2026-03-26 00:00:00	1	3	2	1	49.7	-1.4	49.9	73.1	73.7	72.9	226	228.6	227.9	0.995	0	0	16.4	16.7	16.5	-0.5	-0.3
8	2026-03-26 00:00:00	1	3	2	1	49.8	-1.4	50	72.9	73.6	72.9	226.1	228.6	227.4	0.995	0	0	16.4	16.7	16.5	-0.5	-0.3
9	2026-03-26 00:00:00	1	3	2	1	49.7	-1.5	49.9	73.1	73.5	73	226.6	228.4	227.5	0.995	0	0	16.4	16.7	16.5	-0.5	-0.3
10	2026-03-26 00:00:00	1	3	2	1	49.7	-1.5	49.9	73.1	73.7	73	225.8	228.1	228.8	0.995	0	0	16.4	16.7	16.5	-0.5	-0.3
11	2026-03-26 00:00:00	1	3	2	1	49.7	-1.3	49.9	73	73.7	72.9	226.1	228.3	227.2	0.995	0	0	16.4	16.7	16.5	-0.4	-0.3
12	2026-03-26 00:00:00	1	3	2	1	49.7	-1.5	49.9	73	73.6	72.9	226	228.6	227.6	0.995	0	0	16.4	16.7	16.5	-0.5	-0.3
13	2026-03-26 00:00:00	1	3	2	1	49.7	-1.4	50	72.9	73.6	72.9	226.5	228.8	227.5	0.995	0	0	16.5	16.7	16.5	-0.5	-0.3

Summary: Total 2345 | 1 | 2 | 3 | 4 | 5 | 6 | ... | 118 | 20page | Go to 1

4.8 Alarm Management

The Alarm Management page is divided into three sub-windows. Window 1 displays the number of alarms for the current day and their corresponding alarm levels; Window 2 displays the number of alarms for the current month and their corresponding alarm levels; Window 3 shows current unresolved alarms and a quick alarm query bar.



4.9 Operation Log

Click **Operation Log** in the System Management navigation bar to access the Operation Log page, which records system operations such as account logins and logouts, strategy modifications, command issuance, and file downloads. The information page is shown in the figure below:

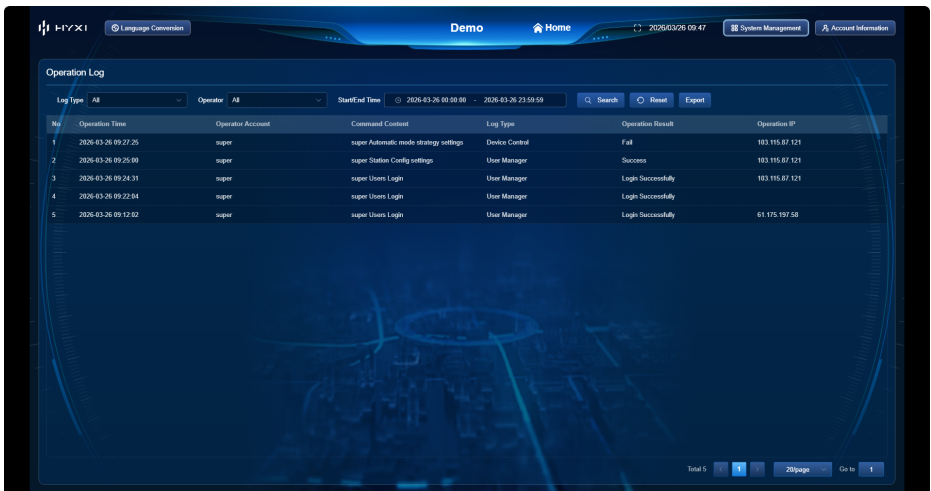

The log query function allows you to filter records using the search bar for precise searches, as shown below. You can filter by log types (device control/user manager), and by operator (super/admin):

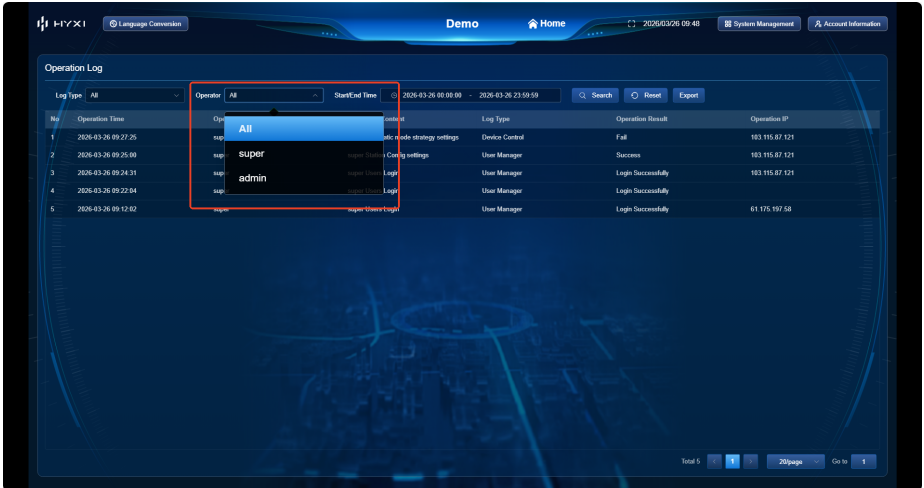
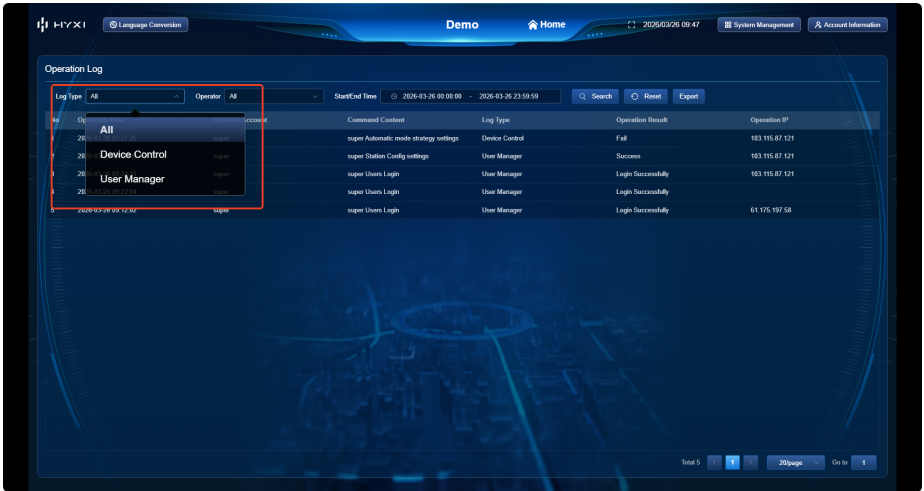

You can also use the time range to search for operations within a specific timeframe, as shown in the figure below:

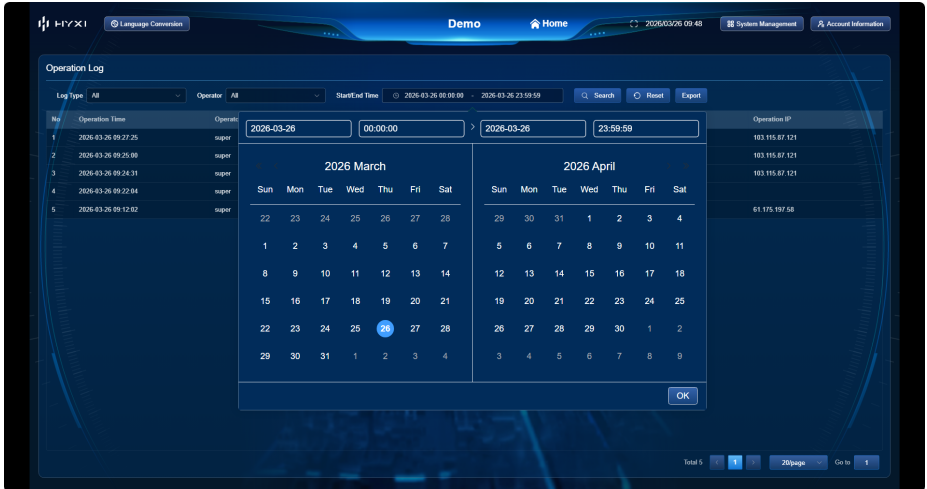

4.10 Upgrade and Maintenance

Click **Upgrade and Maintenance** in the System Management navigation bar to access the Upgrade and Maintenance page. This page displays the current system version and allows you to upload the target version for upgrade, and query and manage historical versions. The information page is shown below:

During the upgrade and maintenance process, a secondary confirmation pop-up will appear. The confirmation button has a 5-second timeout to prevent accidental operations.

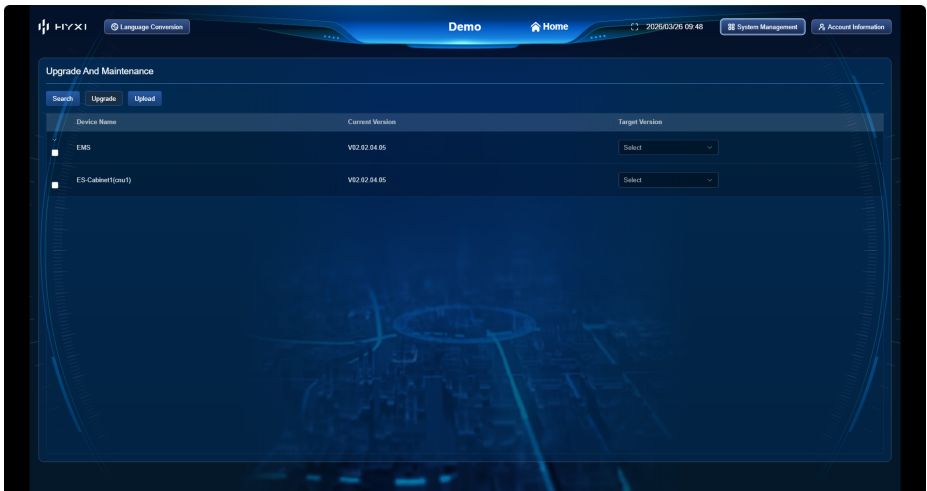

4.11 Electricity Price Management

Click **Electricity Price Management** in the System Management navigation bar to enter the Electricity Price Management page. This page allows you to set electricity prices and manage price templates. The information page is shown below:



In the sub-page navigation bar, select **Electricity Price Management** to enter the electricity price settings page:

Step 1: First, configure the **Electricity Price Template**. Click the **Add** button to set the relevant electricity prices for **Sharp, Peak, Flat, Valley and Deep Valley** periods. You can create multiple templates and configure specific times and purchase and sale prices for different time slots.



Step 2: Configure different electricity price for each month. Select a template for each month to complete the annual rate configuration.



5 Maintenance & Precautions

Maintenance and System Precautions: To ensure continuous and normal system operation, regular maintenance and servicing are required:

- Regularly inspect connection cables for signs of aging and ensure cable connection points are secure and safe.
- After system maintenance, conduct a test run before resuming operation to ensure reliable performance.
- If the product malfunctions and fails to operate, refer to the instructions for preliminary troubleshooting and resolution;
- If the issue persists, please contact our engineering staff as soon as possible. Do not disassemble parts or perform unauthorized maintenance on your own.

6 Contact Information

If you have any questions about this product, please contact us.

In order to provide you with faster and better after-sales service, we need your assistance in providing the following information.

- Equipment model : _____
- Serial number of the device: _____
- Fault code / name: _____
- A brief description of the fault phenomenon: _____

Version: UM_HYX-iEMS Smart Energy Management System_V1.0-202604_EN
The manual is subject to change without notice while the product is being improved.



Zhejiang Hyxi Technology Co., Ltd.

Address: No. 57 Jiang'er Road, Changhe Subdistrict, Binjiang District, Hangzhou city, Zhejiang Province, China

Website: www.hyxipower.com

E-mail: support@hyxipower.com