

RECHARGABLE LITHIUM-ION BATTERY SYSTEM

HYX-E160-L



Carefully read this user manual before using the product.
Read and save these instructions.



© **ZHEJIANG HYXI TECHNOLOGY CO., LTD. All rights reserved.**

This document cannot be copied fully or partially, transferred, or distributed in any form without the prior written permission of ZHEJIANG HYXI TECHNOLOGY CO., LTD (hereinafter referred to as "HYXI").

TRADEMARKS



and other HYXI trademarks are the trademarks or registered trademarks of HYXI All other trademarks mentioned herein are the properties of their respective owners.

Contents

About the Manual	1
Overview	1
Scope of Application	1
For Readers	1
Use of the Manual.....	1
Use of Symbols	2
1 Safety Instructions	3
1.1 Symbols on the Label.....	4
1.2 Safety Precautions.....	4
1.3 Response to Emergency Situations	6
1.4 Personnel Requirements.....	7
2 Inspection & Unpacking	8
2.1 Inspection	8
2.2 Packing List	8
3 Pre-Installation Preparation	9
3.1 Installation Tools Requirement	9
3.2 Location and Environmental Requirement	9
3.2.1 Installation Angle	10
3.2.2 Installation Position	10
3.2.3 Installation Space.....	10
4 Product Overview	11
4.1 Product Dimensions	11
4.2 Terminal Description	12
5 Mechanical Installation	13
6 Electrical Connection	15
6.1 Grounding Connection	15
6.2 Power Cable Connection.....	16
6.3 Communication Connection	16
6.3.1 RS485+CAN Port (External CAN/RS485 Communication).....	17
6.3.2 RS485 Port (Internal RS485 Communication)	17
6.4 Parallel Connection Diagram.....	18
7 LED Description	19
8 System Commissioning	20
8.1 System Startup	20
8.2 System Shutdown	20

9 Online Monitoring	20
10 Maintenance and Troubleshooting	21
10.1 Routine Maintenance	21
10.2 Troubleshooting	22
10.2.1 General Troubleshooting	22
10.2.2 Alarm Description	23
11 Appendix	24
11.1 Technical Parameter.....	24
11.2 Contact Information	25

About the Manual

Overview

To ensure the proper installation and use of the product and its superior performance, before installation and operation of the product, please read the operating instructions in detail and follow all safety precautions in the instructions.

Scope of Application

This manual is intended for the following device:

- HYX-E160-L

Item	Description
HYX	Brand name
E	Energy Storage
160	Capacity
L	Low Voltage

For Readers

This manual is intended for professional technicians who need to install, operate and maintain the product and for users who need to check the product parameters.

All installation operations must be carried out by professional technicians and only by professional technicians.

Use of the Manual

Please read the manual carefully before using the product, the content of the manual will be updated and corrected, but it is inevitable that there is a slight discrepancy or error with the actual product. Users should refer to the actual product purchased and obtain the latest version of the manual by downloading from www.hyxipower.com or through sales channels.

The latest version of the manual is available for download at or through sales channels.

Use of Symbols

To ensure user safety and property protection during product use, relevant information is provided and highlighted with the following symbols.

DANGER

- Indicates a high potential hazard that, if not avoided, could result in death or serious injury.

WARNING

- Indicates a moderate potential hazard that could result in death or serious injury if not avoided.

CAUTION

- Indicates a low potential hazard which, if not avoided, could result in moderate or minor injury.

NOTICE

- Indicates a potential risk which, if not avoided, could result in the equipment not functioning properly or in property damage.

1 Safety Instructions

HYXI energy storage low voltage can provide a variety of operating modes according to different needs, self-generation, peak-shaving, battery priority, etc.







For safety, all operations including transportation, storage, installation, usage and maintenance must comply with applicable laws, regulations, standards and specifications. Incorrect operation or use will endanger:

- Life and personal safety of operators or third parties.
- Other property of the operators or third parties.

HYXI is not responsible in the event of any of the following:

- It does not operate in the conditions of use described in this manual.
- The installation and use environment do not comply with the provisions of the relevant international or national or regional standards.
- Unauthorized disassembly, modification of the product or modification of the software code.
- Failure to follow the operating instructions and safety warnings in the product and documentation.
- Equipment damage caused by abnormal natural environment (force majeure, such as earthquake, fire, windstorm, flood, mudslide, etc.).
- Damage to equipment caused by abnormal natural environment (force majeure, such as earthquake, fire, storm, flood, mudslide, etc.)
- Transportation damage caused by the customer's own transportation.
- Damage caused by storage conditions that do not meet the requirements of the product documentation.
- Damage to the hardware or data of the equipment due to customer negligence, improper operation or intentional damage.
- Damage to the system caused by a third party or the customer, including damage caused by handling and installation that does not meet the requirements of this manual, and damage caused by adjustments, alterations, or removal of identification marks that do not meet the requirements of this manual.

1.1 Symbols on the Label

Symbol	Description
	Risk of danger! There are potential hazards when the equipment is in operation, please take precautions when operating the equipment.
	Beware of electric shock! High voltage exists when the equipment is in operation, so when operating the equipment, make sure the equipment is powered off.
	Keep away from open flames or sources of ignition.
	Do not dispose of the product together with the household waste.
	Please use the equipment reasonably, extreme conditions of use, the equipment has the risk of explosion.
	Observe enclosed documentation.
	Wear protective gloves.

1.2 Safety Precautions

NOTICE

- When installing, operating and maintaining the equipment, please read this manual and follow all safety precautions marked on the equipment and in the manual.

NOTICE

- The "NOTICE", "CAUTION", "WARNING" and "DANGER" items in this manual do not represent all safety items to be observed. They are in addition to all safety precautions. HYXI shall not be liable for any violation of the general safety requirements or for any violation of the safety standards for the design, manufacture and use of the equipment.
- The operation of transportation, turnover, installation, wiring and maintenance shall meet the laws, regulations and related standards of the country and region where it is located.
- The user's own materials and tools required for operation must meet the laws and regulations and related standards of the country or region where they are located.

NOTICE

- Permission must be obtained from the power department of the country or region in which the system is located before it can be connected to the grid.

CAUTION

- The equipment should be used in an environment that conforms to the design specifications; otherwise, equipment failure may result, and the resulting abnormal functioning of the equipment or damage to components, personal safety accidents, and property damage are not covered by the equipment warranty.
- Local laws, regulations and codes should be observed when installing, operating and maintaining the equipment. The safety precautions in the manual are intended only as a supplement to local laws and regulations and norms.
- Lifting or lowering the system carries the risk of injury. The battery is heavy. There is a risk of injury if the battery is not lifted or dropped properly during transport or during installation or removal. Two or more people must lift and transport the battery.
- You should be fully familiar with the composition and working principle of the whole grid- connected photovoltaic power generation system and the relevant standards of the country/ region where the project is located.
- Reverse engineering, decompiling, disassembling, adapting, implanting or other derivative operations of the equipment software are prohibited. It is not allowed to study the internal implementation of the equipment, obtain the source code of the equipment software, steal intellectual property rights, etc. in any way, nor shall the results of any equipment software performance test be disclosed.

DANGER**Risks of Explosion:**

- Do not subject the battery module to heavy impacts;
- Do not crush or puncture the battery module;
- Do not dispose of the battery module in a fire.

DANGER**Risks of Fire:**

- Do not expose the battery module to temperature exceeding 140° F (6° C);
- Do not place the battery module near a heat source, such as a fireplace;
- Do not expose the battery module to direct sunlight;
- Do not allow the battery connectors to touch conductive objects such as wires.

⚠ DANGER**Risks of Electric Shock:**

- Do not disassemble the battery module;
- Do not touch the battery module with wet hands;
- Do not expose the battery module to moisture or liquids;
- Keep the battery module away from children and animals.

⚠ DANGER**Risks of Damage to The Battery Module:**

- Do not expose the battery module to liquids;
- Do not subject the battery module to high pressures;
- Do not place any objects on top of the battery module;
- It shall be protected from the sun and rain.

1.3 Response to Emergency Situations

Leaking batteries:

In case the leakage of electrolyte solution occurs, please avoid direct contact with the electrolyte solution and the gas that may be generated by it. Direct contact may lead to skin irritation or chemical burns. If the user comes into contact with the electrolyte solution, please do as follows:

Situation	Response
Accidental inhalation of harmful substances	Evacuate from the contaminated area, and seek medical attention immediately.
Eye contact	Rinse eyes with flowing water for 15 minutes, and seek medical attention immediately.
Dermal contact	Wash the affected area thoroughly with soap and water, and seek medical attention immediately.
Ingestion	Induce vomiting, and seek medical attention immediately.

Fire:

Please keep a Class ABC fire extinguisher or a carbon dioxide extinguisher near the equipment.



If a fire breaks out where the battery module is installed, please do as follows:

- Extinguish the fire before the battery module catches fire;
- If the battery module catches fire, please do not try to put out the fire, and evacuate immediately.

Wet batteries and damaged batteries:

- Do not touch the battery module after being wet from and soaked in the water.
- Do not use the battery module if it is damaged. Otherwise, the loss to life and property will be caused.
- Please pack the battery in its original packaging, and return it to our company or the distributor.

1.4 Personnel Requirements

⚠ CAUTION

- Personnel responsible for the installation and maintenance of HYXI equipment must first be strictly trained to understand various safety precautions and master the correct operation methods.
- Only qualified professionals or trained personnel are allowed to install, operate and maintain the equipment.
- Only qualified professionals are allowed to remove safety facilities and overhaul equipment.
- Personnel who operate the equipment, including operators, trained personnel, and professionals should have the local state required special operating qualifications, such as high voltage operation, ascent, and special equipment operation qualifications.
- Replacement of equipment or parts (including software) must be done by professionals or authorized personnel.

Professional personnel:

- People who have training or experience in operating equipment and can clearly understand the various potential sources and magnitudes of hazards during equipment installation, operation, and maintenance.

Trained personnel:

- A person who has received the appropriate technical training and has the necessary experience to be aware of the hazards that may be presented to him when performing a particular operation and to take measures to minimize the hazards to himself or to other personnel.

2 Inspection & Unpacking

2.1 Inspection





The equipment has been completely tested and strictly inspected before leaving the factory, but it may still be damaged during transportation, please make a detailed inspection before signing the product.

- Check whether there is any damage to the packing box.
- Check if the goods are complete and in accordance with the packing list.
- Unpack and check if the equipment inside is intact.

If there is any damage or incomplete goods, please contact with the shipping company or directly with Zhejiang Hyxi Technology Co., Ltd.

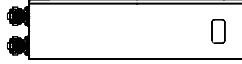
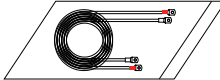
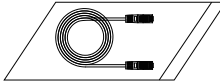
Provide photos of the damage to facilitate the provision of services.

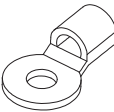
2.2 Packing List

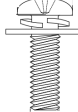
No.	Accessories	Item	Quantity
1		Battery	1
2		Power cable	1
3		Communication cable	1
4		User manual	1
5		M8*60 expansion screws	2
6		OT4-5 OT terminal for grounding	1
7		Buckles	2
8		M5*12 screws	2

9		RJ45 terminals	2
---	---	----------------	---

3 Pre-Installation Preparation

3.1 Installation Tools Requirement

Installation tools include, but are not limited to, the following recommended tools. And if necessary, other auxiliary tools can be used on site.

The following tools are not included in this package. Please make sure they are ready before installation and electrical connections.

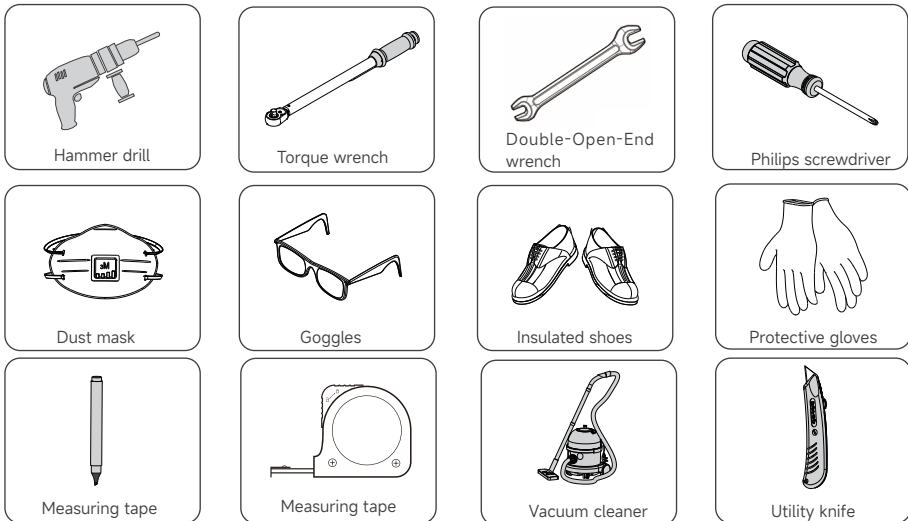

3.2 Location and Environmental Requirement

- The battery enclosure has an IP20 protection rating and could be installed indoors.
- The battery has no ventilation requirements.
- The battery housing should be installed in a location free from the risk of water (standing water, submersion, etc.). The installation location must be well drained.
- The product needs to be installed on a level surface.

The following places are not allowed to be installed:

- In environments where the temperature is less than -20°C or more than 60°C .
- Places where humidity and condensation exceed 95%.
- Places where salt and humid air can penetrate.
- Flooded areas.

- Earthquake areas - additional safety measures are required here.
- Locations at altitudes above 2000 meters.
- Explosive atmospheres.
- Locations with prolonged exposure to sunlight.
- Places where the ambient temperature changes drastically.
- Humid rooms.
- Locations with highly flammable materials or gases.
- Locations with a potentially explosive atmosphere.

3.2.1 Installation Angle

The product supports installation on the ground and with the anti-tilting device, do not tilt the product forward, horizontal, upside down, backward and sideways installation.

3.2.2 Installation Position

If you choose other types of walls and floors, the walls and floors should meet the load-bearing requirements of the equipment, and the walls and floors where the installation is located should have fire retardant properties.

3.2.3 Installation Space

When installing this product, make sure there is no other equipment (except for the installation of necessary equipment, masking devices) and flammable and explosive materials around, and reserve sufficient installation space as shown in the following figure to ensure installation, heat dissipation, safety and other needs.

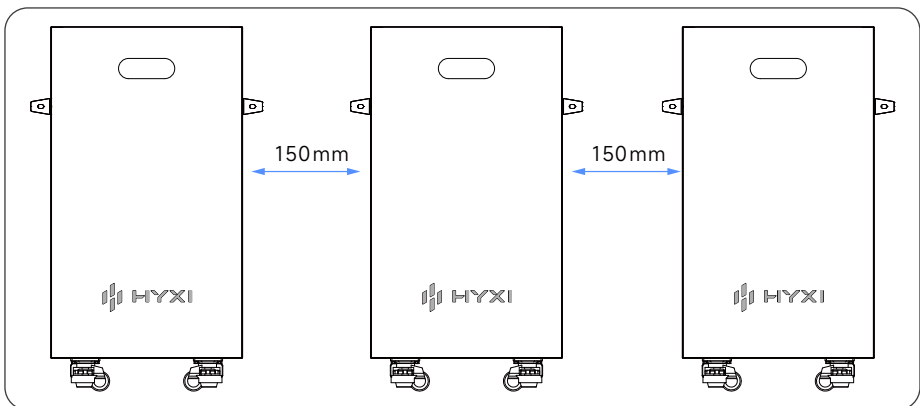

4 Product Overview

4.1 Product Dimensions

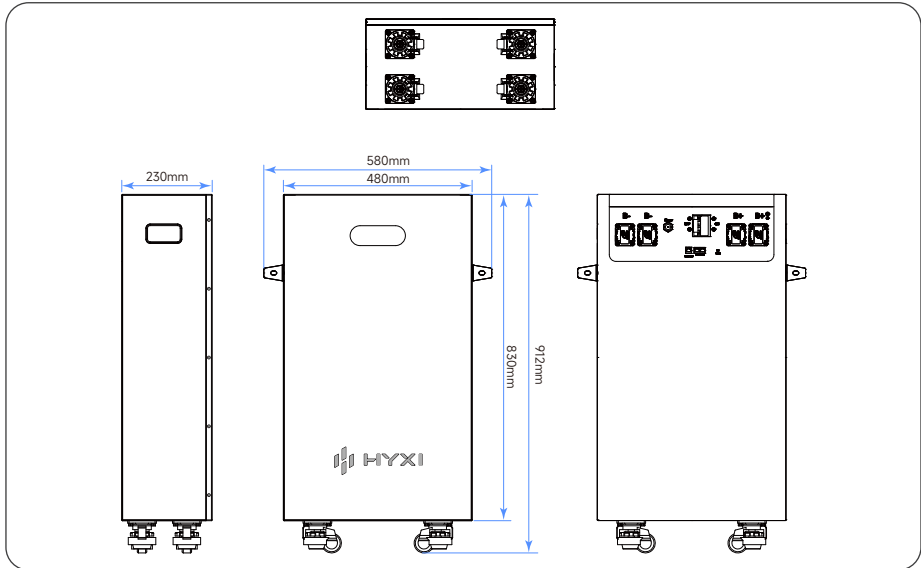

4.2 Terminal Description

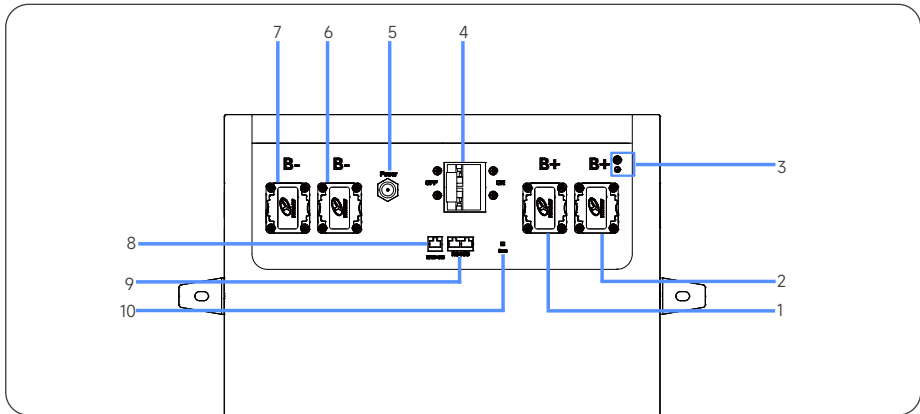

No.	Item	Function
1	B+	Connecting to the battery positive port of the inverter
2	B+	Connecting to the next battery positive port for parallel
3	Grounding port	Connecting to the PE bar
4	Breaker	To connect or disconnect the connection between the inverter and the battery
5	Power	To power on/off the battery
6	B-	Connecting to the next battery negative port for parallel
7	B-	Connecting to the battery negative port of the inverter
8	RS485 + CAN	Communication with the inverter
9	RS485	Communication with the battery for parallel
10	Reset	To reset the communication protocol

5 Mechanical Installation

NOTICE

- The battery is heavy. There is a risk of injury if the battery is not lifted or dropped properly during transportation or during installation or removal.
- Two or more people must lift and transport the battery. The battery has wheels; after moving it to the corresponding position using the wheels, the wheels need to be locked.
- The electrical connection must be complete and firm.
- The installer should wear protective equipment.

DANGER

- The battery should be securely fixed in a reasonable usage environment , and the connector should be reliably connected to avoid arcing and sparks caused by friction and ignition of the connector.
- Make sure handle the battery with care , and protect it from mechanical vibration , collision , and pressure impact. Otherwise , the battery may experience internal short circuits, high temperatures , and fires.
- Before drilling, please make sure to avoid the pre-buried utility lines in the wall to avoid danger.
- To prevent dust from entering human respiratory tract or eyes when punching holes, personnel should wear appropriate protective gear.

Step 1: Open the battery packaging and place the battery upright.

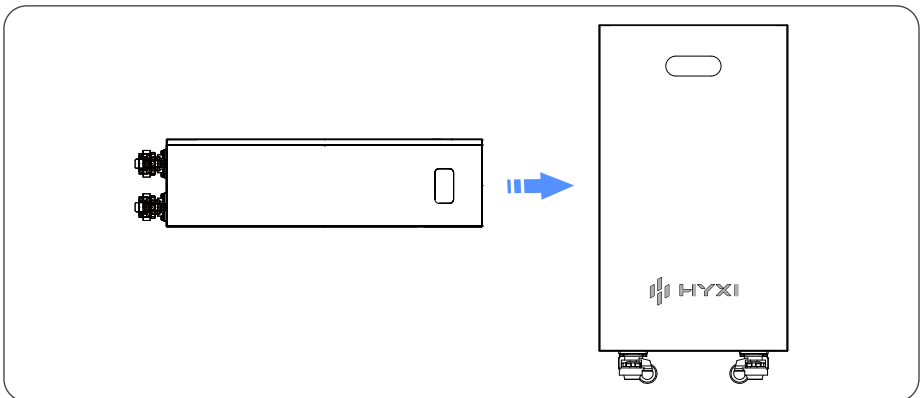

Step 2: Then place the battery in the corresponding installation position, and then make sure the distance between the battery and the wall is 0-60 mm.

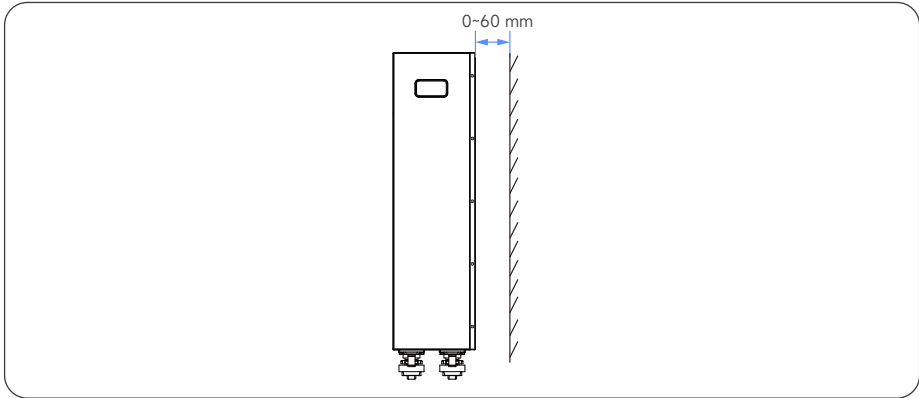

Step 3: Rotate the red gear clockwise to fix the battery. To adjust the battery's position, rotate the gear counterclockwise to move the battery.

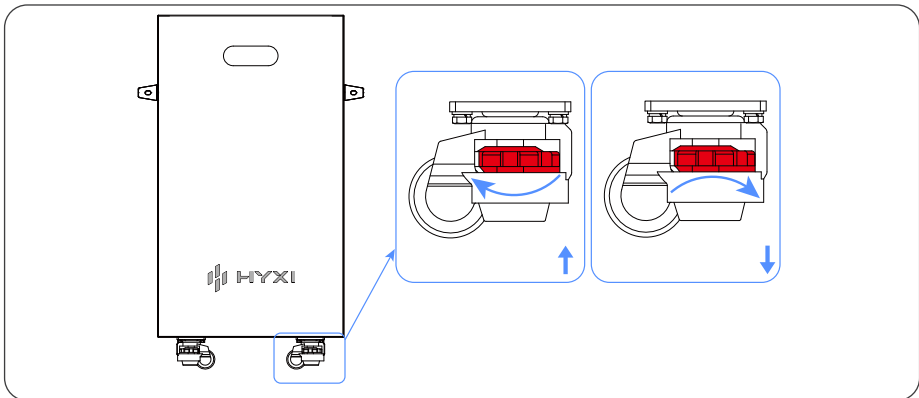

Step 4: Use expansion screws to fix the battery in the wall.

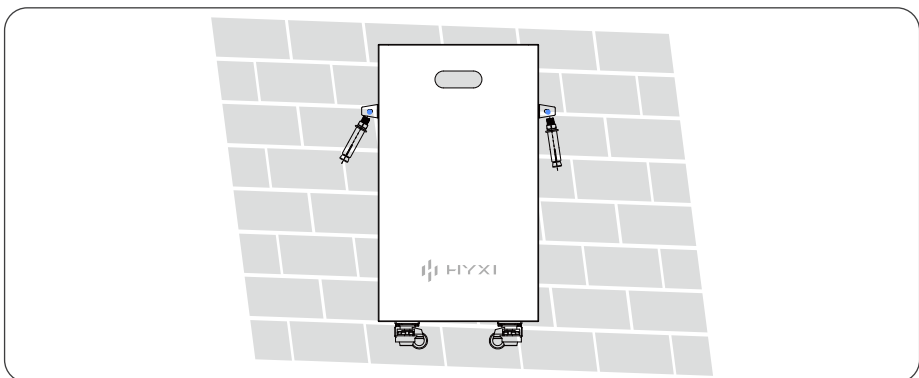

6 Electrical Connection

6.1 Grounding Connection

NOTICE

- The grounding cable is to be prepared by the customer.

Step 1: Strip the insulation layer of the grounding cable.

Step 2: Insert the heat shrink tubing and OT terminal into the grounding cable.

Step 3: Use a crimping tool to crimp the OT terminal.

Step 4: Wrap the wire crimping area with the heat shrink tubing, then heat it with a heat gun.

Step 5: Use M5*12 screw from the accessory to secure the grounding cable. (Torque: 4N.m)

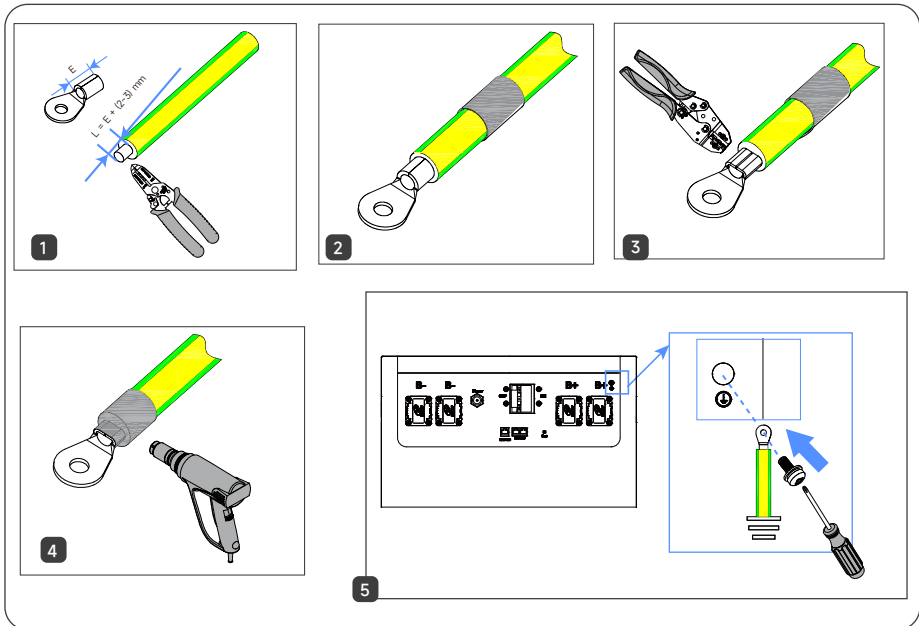

6.2 Power Cable Connection

Connect B- to the battery negative port of the inverter, and B+ to the battery positive port of the inverter.

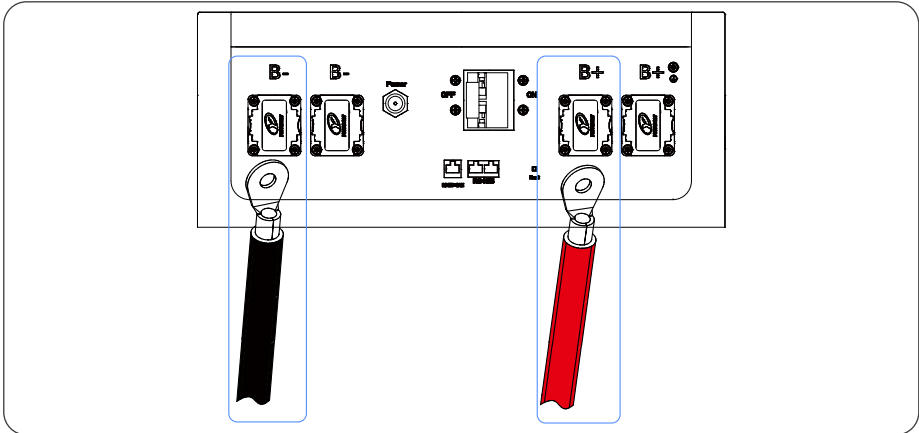

6.3 Communication Connection

Insert the RJ45 terminal into the RS485+CAN port.

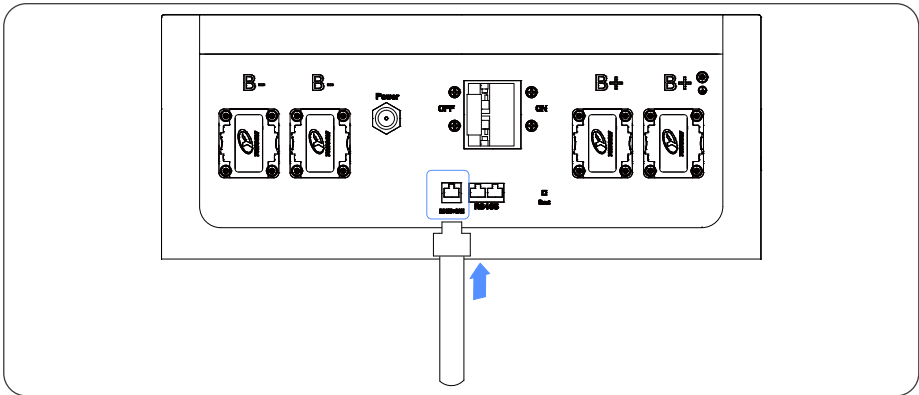

6.3.1 RS485+CAN Port (External CAN/RS485 Communication)

BMS has CAN/RS485 communication function for battery pack upload (address 1 , baud rate 500K). The RS485+CAN Port adopts an CAT5 Ethernet interface , which can communicate with the inverter through the CAN/RS485 interface. When the battery pack is connected, it is connected through internal CAN/RS485 communication, and finally the battery pack data, status, and information are uploaded to PCS through CAN/RS485 communication .

Definition of RS485+CAN Port:

Pin	Definition
1	485B1
2	485A1
3	ISO_GND
4	CAN1_H
5	CAN1_L
6	GND
7	TX
8	RX

6.3.2 RS485 Port (Internal RS485 Communication)

When multiple batteries are connected in parallel , the RS485 port serves as the parallel communication interface, while the RS485+CAN Port serves as the uplink communication interface.

The terminal device can read the sum of battery data from all parallel PACK's through an external RS485/CAN interface. When multiple machines are connected in parallel, the internal RS485 interface connection is shown in the following figure:

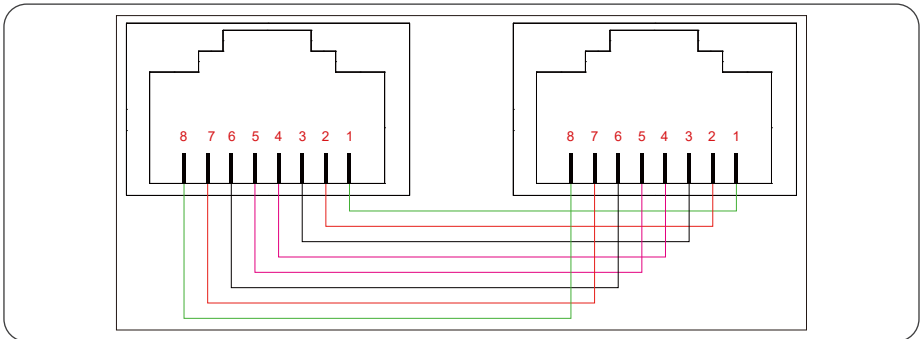

Pin	Definition	Pin	Definition
1	485B2	1	485B2
2	485A2	2	485A2
3	ISO_GND	3	ISO_GND
4	TBD	4	TBD
5	TBD	5	TBD
6	ISO_GND	6	ISO_GND
7	485A2	7	485A2
8	485B2	8	485B2

6.4 Parallel Connection Diagram

The battery supports up to 15 batteries to parallel.

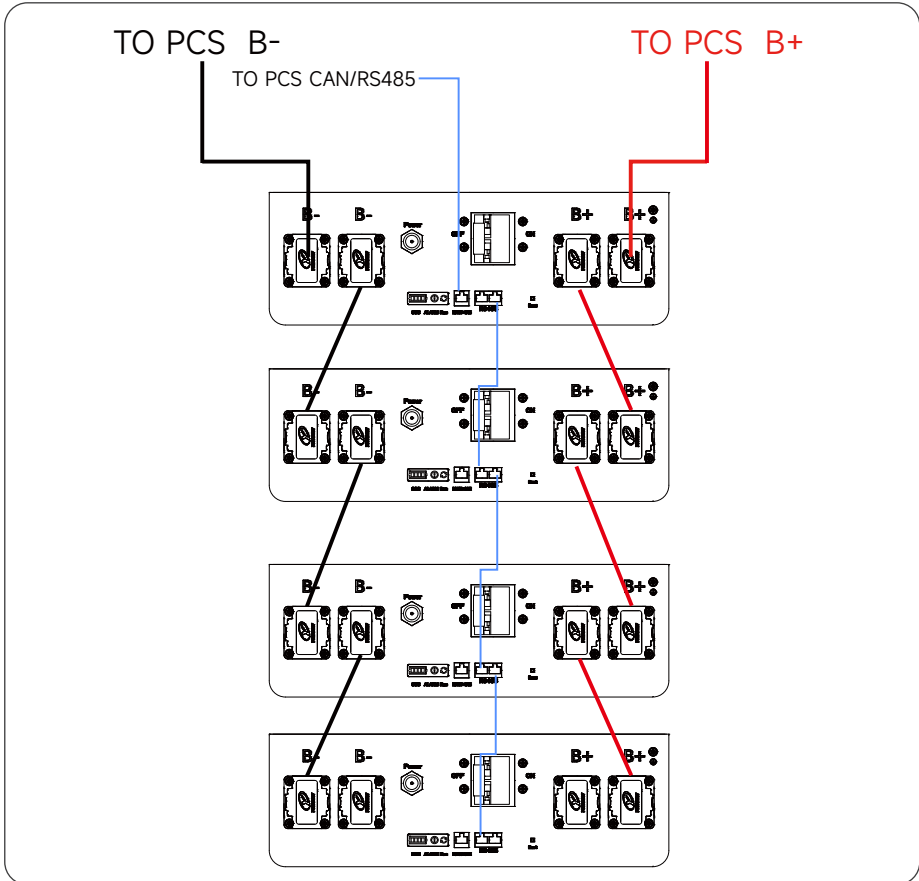







⚠ DANGER

- This battery cannot be used in series.
- When multiple battery pack 's using this circuit board are connected in parallel , it should be ensured that the maximum voltage difference between each battery pack before parallel connection is less than 3V.
- When multiple battery pack 's using this circuit board are connected in parallel , the total charging surge current of the adapter may be applied to a single battery pack. It should be ensured that the total charging surge current of the adapter does not exceed the maximum charging surge current of a single BMS.

7 LED Description



Icon	Description
	$0 \leq \text{SOC} < 20\%$
	$20 \leq \text{SOC} < 40\%$
	$40 \leq \text{SOC} < 60\%$
	$60 \leq \text{SOC} < 80\%$
	$80 \leq \text{SOC} < 100\%$
	No malfunction or Level 3 alarm
	First level fault and second level fault

8 System Commissioning

8.1 System Startup

Step 1: Press the power button of the low-voltage switch power supply, the green LED will light up, indicating successful power-on. There should be an interval of more than 5s between the two operations.

Step 2: Turn on the breaker.

8.2 System Shutdown

Step 1: Turn off the breaker.

Step 2: Press the power button of the low-voltage switch power supply, the button will reset and the indicator light will turn off. There should be an interval of more than 5s between the two operations.

9 Online Monitoring

All the battery data is uploaded to the inverter, and the monitoring is uploaded from the inverter side.

10 Maintenance and Troubleshooting

10.1 Routine Maintenance

If the energy storage system is not used for more than three months, it is necessary to charge the energy storage battery to a full charge to avoid over-discharge due to self-consumption of the system.

NOTICE

- Please keep the battery in a half charged state , with a suitable SOC of 40%~ 80%. Please wrap the battery with non-conductive material to prevent direct metal contact and damage to the battery. Please store the battery in a cool and dry place.

Precautions for charge and discharge operation:

- When the summer temperature is high (35 °C) , fast charging should not be used for daytime battery charging. If fast charging is needed during the day, try to use it with a discharge interval of more than 1 hour, and the charging time should not exceed half an hour to avoid the high temperature of the battery affecting use.
- When the temperature is low (<0 °C) in winter, the battery should be charged as soon as possible after discharge to prevent the charging time from being prolonged due to the low temperature of the battery, which may affect its use.

Product cleaning:

Step 1: First, gently wipe the surface with a soft microfiber cloth to remove dust or debris.

Step 2: Moisten the cloth with water (neutral detergent can also be added) and wring out excess water.

Step 3: Wipe away any debris or dirt.

Step 4: Finally, wipe off all water from the surface with a dry microfiber cloth.

CAUTION

- The cleaning process should be carried out away from electrical connections to prevent water from getting inside the product housing, connection ports, etc.
- Do not wipe the product with reagents other than water (H₂O).

10.2 Troubleshooting

10.2.1 General Troubleshooting

Battery communication failure:

- Failure analysis: CAN communication or 485 communication failure.
- Solution: Check if the communication line is in good contact.

Battery over-undervoltage fault:

- Failure analysis: Voltage range is not compatible with the battery and the battery energy is insufficient.
- Solution: Check the battery voltage, PV or whether it will be charged automatically when there is grid.

Overload fault:

- Failure analysis: The load is too large.
- Solution: Check whether the load exceeds the machine power, all down and then part of the load up.

Output short circuit fault:

- Failure analysis: There is a short circuit working condition on the load side.
- Solution: All power down, after the power indicator goes off, check whether the load is short-circuited, and then power up after troubleshooting.

10.2.2 Alarm Description

The following alarms are recoverable alarms, please refer to the following table to process and resume operation.

Fault name	Action	Recovery conditions
Battery discharge overcurrent	Prohibition of discharge/high voltage relay disconnection	<ul style="list-style-type: none"> Turn off part of the load. Reboot the device.
Battery charging overcurrent	Prohibition of charge/high voltage relay disconnection	<ul style="list-style-type: none"> Restart the device. Contact HYXI after-sales staff to solve.
Battery charging over-voltage	Prohibition of charge/ high voltage relay disconnection	<ul style="list-style-type: none"> Restart the device. Contact HYXI after-sales staff to solve the problem.
Battery discharge undervoltage	Prohibition of discharge/high voltage relay disconnection	<ul style="list-style-type: none"> Restart the device. Contact HYXI after-sales staff to solve the problem.
Battery discharge high temperature	Prohibition of discharge/high voltage relay disconnection	<ul style="list-style-type: none"> Turn off the load of the equipment, and leave it until the battery temperature is less than 40°C . Contact HYXI after-sales personnel to solve.
Battery charging high temperature	Prohibition of charge/high voltage relay disconnection	<ul style="list-style-type: none"> Leave the battery temperature less than 40°C . Contact HYXI after-sales personnel to solve.
Battery discharging low temperature	Prohibition of discharge/high voltage relay disconnection	<ul style="list-style-type: none"> Leave to wait for the battery temperature is greater than 2°C . Contact HYXI after-sales personnel to solve.
Loss of communication with PCS	High Voltage Relay Disconnection	<ul style="list-style-type: none"> Check the connection between Pack and PCS harness. Contact HYXI after-sales staff to solve the problem.
Pre-charge fault	Prohibit high voltage	<ul style="list-style-type: none"> Restart the device. Contact HYXI after-sales staff to solve the problem.
BMS self-test fault	Prohibit high voltage	<ul style="list-style-type: none"> Restart the device. Contact HYXI after-sales staff to solve the problem.
Battery temperature detection sensor failure	Prohibit high voltage/Prohibit charging and discharging/ Disconnecting high voltage relay	<ul style="list-style-type: none"> Restart the device. Contact HYXI after-sales staff to solve the problem.
Cell voltage sampling line failure	Prohibit high voltage/Prohibit charging and discharging/ Disconnecting high voltage relay	<ul style="list-style-type: none"> Restart the device. Contact HYXI after-sales staff to solve the problem.

11 Appendix

11.1 Technical Parameter

No.	Items	Specifications	Notes
1	Nominal energy	16.07kWh	Standard charge/discharge mode test
2	Series-parallel connection method	1P16S	1P16S
3	Nominal capacity	314Ah	Standard charge/discharge mode test
4	Nominal voltage	51.2V	/
5	Operating voltage range	43.2 ~ 58.4V	Temperature range: -20 ~ 60°C
6	Operating temperature (charging)	-20 ~ 60°C ≤ 90%ROH	/
7	Operating temperature (Discharging)	-20 ~ 60°C ≤ 90%ROH	/
8	Standard charging	Constant current charging: 157A Charging voltage: 57.6V Cut-off current: 5A	Maximum cell voltage 3.65V
9	Maximum continuous charging current	Constant current charging: 205A Charging voltage: 57.6V Cut-off current: 5A	Maximum cell voltage 3.65V
10	Standard discharge	Constant current discharge : 157A Cut-off voltage : 43.2V	Minimum cell voltage 2.7V
11	Maximum continuous discharge current	Constant current discharge : 205A Cut-off voltage : 43.2V	Minimum cell voltage 2.7V
12	Storage temperature	-20~60°C	Storage environment humidity: ≤ 95% ROH, no condensation.
13	Cycle life	6000 @70%SOH	90% DOD, @25±2°C , standard charge and discharge mode
14	Monthly self-discharge	<2% per month	After three months' shipment, the battery will be charged to 30%soc and stored at@ 25±2°C
15	Communication equipment	RS485/CAN	/
16	Equalization method	Passive equalization	/
17	Net weight	130 kg	/
18	Dimension (W*H*D)	480*830*230 ±1mm	Overall dimensions without wheels and buckles: 480*830*230mm

11.2 Contact Information

If you have any questions about this product, please contact us.

In order to provide you with faster and better after-sales service, we need your assistance in providing the following information.

- Equipment model : _____
- Serial number of the equipment: _____
- Fault code / name: _____
- A brief description of the fault phenomenon: _____

Version: UM_HYX-E160-L_V1.0-202603_EN

The manual is subject to change without notice while the product is being improved.



Zhejiang Hyxi Technology Co., Ltd.

Building 1, No. 57 Jiang'er Road, Changhe Street, Binjiang District,
Hangzhou, Zhejiang Province, China

www.hyxipower.com

support@hyxipower.com