

HIGH VOLTAGE BATTERY

HYX-E50-H3 / HYX-E100-H3



Carefully read this user manual before using the product.
Read and save these instructions.



© ZHEJIANG HYXI TECHNOLOGY CO., LTD. All rights reserved.

This document cannot be copied fully or partially, transferred, or distributed in any form without the prior written permission of ZHEJIANG HYXI TECHNOLOGY CO., LTD (hereinafter referred to as "HYXiPOWER").

TRADEMARKS



and other HYXiPOWER trademarks are the trademarks or registered trademarks of HYXiPOWER All other trademarks mentioned herein are the properties of their respective owners.

Contents

About the Manual	1
Overview	1
Scope of Application	1
For Readers	1
Use of the Manual.....	1
Use of Symbols	2
1 Safety Instructions	3
1.1 Symbols on the Label.....	4
1.2 Safety Precautions.....	4
1.3 Response to Emergency Situations	6
1.4 Personnel Requirements.....	7
2 Inspection & Unpacking	8
2.1 Inspection	8
2.2 Packing List	8
3 Pre-Installation Preparation	9
3.1 Installation Tools Requirement	9
3.2 Location and Environmental Requirement	9
3.2.1 Installation Angle	10
3.2.2 Installation Position	10
3.2.3 Installation Space.....	10
4 Product Appearance	11
5 Mechanical Installation	13
5.1 Floor-Mounting	13
5.2 Wall-Mounting.....	14
6 Electrical Connection	16
6.1 Grounding Connection	16
6.2 Battery Connection	17
6.3 Parallel Connection	18
6.4 Electrical and Communication Interfaces.....	20
6.4.1 Communication Interface (COM INV-BAT).....	20
6.4.2 Communication Interface (COM Par BAT-BAT).....	21
6.4.3 Power Button	21
6.4.4 Power Interface	21
7 LED Indicator	22
7.1 LED Display and System Status.....	22

- 7.2 SOC Indicators & Battery Capacity 23
- 8 System Commissioning..... 24**
 - 8.1 System Startup 24
 - 8.2 System Shutdown 24
- 9 Online monitoring..... 25**
- 10 Maintenance and Troubleshooting..... 26**
 - 10.1 Routine Maintenance 26
 - 10.2 Troubleshooting 27
 - 10.2.1 General Troubleshooting 27
 - 10.2.2 Alarm Description 27
- 11 Appendix..... 30**
 - 11.1 Technical Parameter..... 30
 - 11.2 Contact Information 31

About the Manual

Overview

To ensure the proper installation and use of the product and its superior performance, before installation and operation of the product, please read the operating instructions in detail and follow all safety precautions in the instructions.

Scope of Application

This manual is intended for the following device:

- HYX-E50-H3
- HYX-E100-H3

Item	Description
HYX	Brand name
E	Battery Model
50/100	Capacity
H	High Voltage

For Readers

This manual is intended for professional technicians who need to install, operate and maintain the product and for users who need to check the product parameters.

All installation operations must be carried out by professional technicians and only by professional technicians.

Use of the Manual

Please read the manual carefully before using the product, the content of the manual will be updated and corrected, but it is inevitable that there is a slight discrepancy or error with the actual product. Users should refer to the actual product purchased and obtain the latest version of the manual by downloading from www.hyxipower.com or through sales channels.

The latest version of the manual is available for download at or through sales channels.

Use of Symbols

To ensure user safety and property protection during product use, relevant information is provided and highlighted with the following symbols.

DANGER

- Indicates a high potential hazard that, if not avoided, could result in death or serious injury.

WARNING

- Indicates a moderate potential hazard that could result in death or serious injury if not avoided.

CAUTION

- Indicates a low potential hazard which, if not avoided, could result in moderate or minor injury.

NOTICE

- Indicates a potential risk which, if not avoided, could result in the equipment not functioning properly or in property damage.

1 Safety Instructions

HYXiPOWER energy storage high voltage can provide a variety of operating modes according to different needs, self-generation, peak-shaving, battery priority, etc.









For safety, all operations including transportation, storage, installation, usage and maintenance must comply with applicable laws, regulations, standards and specifications. Incorrect operation or use will endanger:

- Life and personal safety of operators or third parties.
- Other property of the operators or third parties.

HYXiPOWER is not responsible in the event of any of the following:

- It does not operate in the conditions of use described in this manual.
- The installation and use environment do not comply with the provisions of the relevant international or national or regional standards.
- Unauthorized disassembly, modification of the product or modification of the software code.
- Failure to follow the operating instructions and safety warnings in the product and documentation.
- Equipment damage caused by abnormal natural environment (force majeure, such as earthquake, fire, windstorm, flood, mudslide, etc.).
- Damage to equipment caused by abnormal natural environment (force majeure, such as earthquake, fire, storm, flood, mudslide, etc.)
- Transportation damage caused by the customer's own transportation.
- Damage caused by storage conditions that do not meet the requirements of the product documentation.
- Damage to the hardware or data of the equipment due to customer negligence, improper operation or intentional damage.
- Damage to the system caused by a third party or the customer, including damage caused by handling and installation that does not meet the requirements of this manual, and damage caused by adjustments, alterations, or removal of identification marks that do not meet the requirements of this manual.

1.1 Symbols on the Label

Symbol	Description
	Risk of danger! There are potential hazards when the equipment is in operation, please take precautions when operating the equipment.
	Beware of electric shock! High voltage exists when the equipment is in operation, so when operating the equipment, make sure the equipment is powered off.
	Keep away from open flames or sources of ignition.
	Do not dispose of the product together with the household waste.
	Please use the equipment reasonably, extreme conditions of use, the equipment has the risk of explosion.
	Observe enclosed documentation.
	Wear protective gloves.
	CE certification mark. The inverter complies with the regulations of CE.

1.2 Safety Precautions

NOTICE

- When installing, operating and maintaining the equipment, please read this manual and follow all safety precautions marked on the equipment and in the manual.

NOTICE

- The "NOTICE", "CAUTION", "WARNING" and "DANGER" items in this manual do not represent all safety items to be observed. They are in addition to all safety precautions. HYXiPOWER shall not be liable for any violation of the general safety requirements or for any violation of the safety standards for the design, manufacture and use of the equipment.
- The operation of transportation, turnover, installation, wiring and maintenance shall meet the laws, regulations and related standards of the country and region where it is located.
- The user's own materials and tools required for operation must meet the laws and regulations and related standards of the country or region where they are located.
- Permission must be obtained from the power department of the country or region in which the system is located before it can be connected to the grid.

⚠ CAUTION

- The equipment should be used in an environment that conforms to the design specifications; otherwise, equipment failure may result, and the resulting abnormal functioning of the equipment or damage to components, personal safety accidents, and property damage are not covered by the equipment warranty.
- Local laws, regulations and codes should be observed when installing, operating and maintaining the equipment. The safety precautions in the manual are intended only as a supplement to local laws and regulations and norms.
- Lifting or lowering the system carries the risk of injury. The battery is heavy. There is a risk of injury if the battery is not lifted or dropped properly during transport or during installation or removal. Two or more people must lift and transport the battery.
- You should be fully familiar with the composition and working principle of the whole grid- connected photovoltaic power generation system and the relevant standards of the country/ region where the project is located.
- Reverse engineering, decompiling, disassembling, adapting, implanting or other derivative operations of the equipment software are prohibited. It is not allowed to study the internal implementation of the equipment, obtain the source code of the equipment software, steal intellectual property rights, etc. in any way, nor shall the results of any equipment software performance test be disclosed.

⚠ DANGER**Risks of Explosion:**

- Do not subject the battery module to heavy impacts;
- Do not crush or puncture the battery module;
- Do not dispose of the battery module in a fire.

⚠ DANGER**Risks of Fire:**

- Do not expose the battery module to temperature exceeding 140° F (6° C);
- Do not place the battery module near a heat source, such as a fireplace;
- Do not expose the battery module to direct sunlight;
- Do not allow the battery connectors to touch conductive objects such as wires.

⚠ DANGER**Risks of Electric Shock:**

- Do not disassemble the battery module;
- Do not touch the battery module with wet hands;
- Do not expose the battery module to moisture or liquids;
- Keep the battery module away from children and animals.

⚠ DANGER**Risks of Damage to The Battery Module:**

- Do not expose the battery module to liquids;
- Do not subject the battery module to high pressures;
- Do not place any objects on top of the battery module;
- It shall be protected from the sun and rain.

1.3 Response to Emergency Situations

Leaking batteries:

In case the leakage of electrolyte solution occurs, please avoid direct contact with the electrolyte solution and the gas that may be generated by it. Direct contact may lead to skin irritation or chemical burns. If the user comes into contact with the electrolyte solution, please do as follows:

Situation	Response
Accidental inhalation of harmful substances	Evacuate from the contaminated area, and seek medical attention immediately.
Eye contact	Rinse eyes with flowing water for 15 minutes, and seek medical attention immediately.
Dermal contact	Wash the affected area thoroughly with soap and water, and seek medical attention immediately.
Ingestion	Induce vomiting, and seek medical attention immediately.

Fire:

Please keep a Class ABC fire extinguisher or a carbon dioxide extinguisher near the equipment.

**If a fire breaks out where the battery module is installed, please do as follows:**

- Extinguish the fire before the battery module catches fire;
- If the battery module catches fire, please do not try to put out the fire, and evacuate immediately.

Wet batteries and damaged batteries:

- Do not touch the battery module after being wet from and soaked in the water.
- Do not use the battery module if it is damaged. Otherwise, the loss to life and property will be caused.
- Please pack the battery in its original packaging, and return it to our company or the distributor.

1.4 Personnel Requirements

CAUTION

- Personnel responsible for the installation and maintenance of HYXiPOWER equipment must first be strictly trained to understand various safety precautions and master the correct operation methods.
- Only qualified professionals or trained personnel are allowed to install, operate and maintain the equipment.
- Only qualified professionals are allowed to remove safety facilities and overhaul equipment.
- Personnel who operate the equipment, including operators, trained personnel, and professionals should have the local state required special operating qualifications, such as high voltage operation, ascent, and special equipment operation qualifications.
- Replacement of equipment or parts (including software) must be done by professionals or authorized personnel.

Professional personnel:

- People who have training or experience in operating equipment and can clearly understand the various potential sources and magnitudes of hazards during equipment installation, operation, and maintenance.

Trained personnel:

- A person who has received the appropriate technical training and has the necessary experience to be aware of the hazards that may be presented to him when performing a particular operation and to take measures to minimize the hazards to himself or to other personnel.

2 Inspection & Unpacking

2.1 Inspection









The equipment has been completely tested and strictly inspected before leaving the factory, but it may still be damaged during transportation, please make a detailed inspection before signing the product.

- Check whether there is any damage to the packing box.
- Check if the goods are complete and in accordance with the packing list.
- Unpack and check if the equipment inside is intact.

If there is any damage or incomplete goods, please contact with the shipping company or directly with Zhejiang Hyxi Technology Co., Ltd.

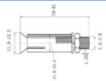
Provide photos of the damage to facilitate the provision of services.

2.2 Packing List

No.	Accessories	Item	Quantity
1		Wall mounting bracket (Optional Purchase for 10kWh)	1
2		Ground mounting bracket	2
3		Wall mounting bracket (Optional Purchase for 10kWh)	2
4		Ground mounting bracket fixing screws (M6*12)	12
5		Expansion screws	6
6		High voltage cable(HV+ 4~6mm ²)	1
7		High voltage cable(HV- 4~6mm ²)	1
8		Communication cable	1

3 Pre-Installation Preparation

3.1 Installation Tools Requirement

Installation tools include, but are not limited to, the following recommended tools. And if necessary, other auxiliary tools can be used on site.

The following tools are not included in this package. Please make sure they are ready before installation and electrical connections.

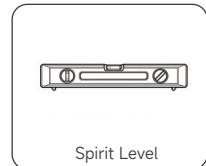
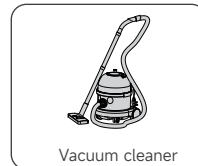
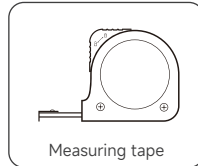
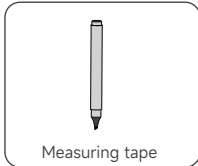
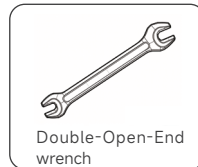
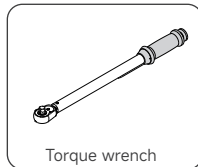

3.2 Location and Environmental Requirement

- The battery enclosure has an IP65 protection rating and could be installed indoors and outdoors.
- The battery has no ventilation requirements.
- The battery housing should be installed in a location free from the risk of water (standing water, submersion, etc.). The installation location must be well drained.
- The product needs to be installed on a level surface.

The following places are not allowed to be installed:

- In environments where the temperature is less than -20°C or more than 50°C .
- Places where humidity and condensation exceed 95%.
- Places where salt and humid air can penetrate.
- Flooded areas.
- Earthquake areas - additional safety measures are required here.
- Locations at altitudes above 3000 meters.
- Explosive atmospheres.

- Locations with prolonged exposure to sunlight.
- Places where the ambient temperature changes drastically.
- Humid rooms.
- Locations with highly flammable materials or gases.
- Locations with a potentially explosive atmosphere.

3.2.1 Installation Angle

The product supports installation on the ground and with the anti-tilting device, do not tilt the product forward, horizontal, upside down, backward and sideways installation.

3.2.2 Installation Position

If you choose other types of walls and floors, the walls and floors should meet the load-bearing requirements of the equipment, and the walls and floors where the installation is located should have fire retardant properties.

3.2.3 Installation Space

When installing this product, make sure there is no other equipment (except for the installation of necessary equipment, masking devices) and flammable and explosive materials around, and reserve sufficient installation space as shown in the following figure (for example, the highest stacking method of this product) to ensure installation, heat dissipation, safety and other needs.

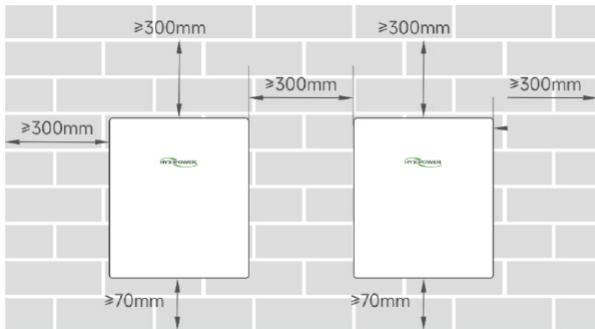

4 Product Appearance

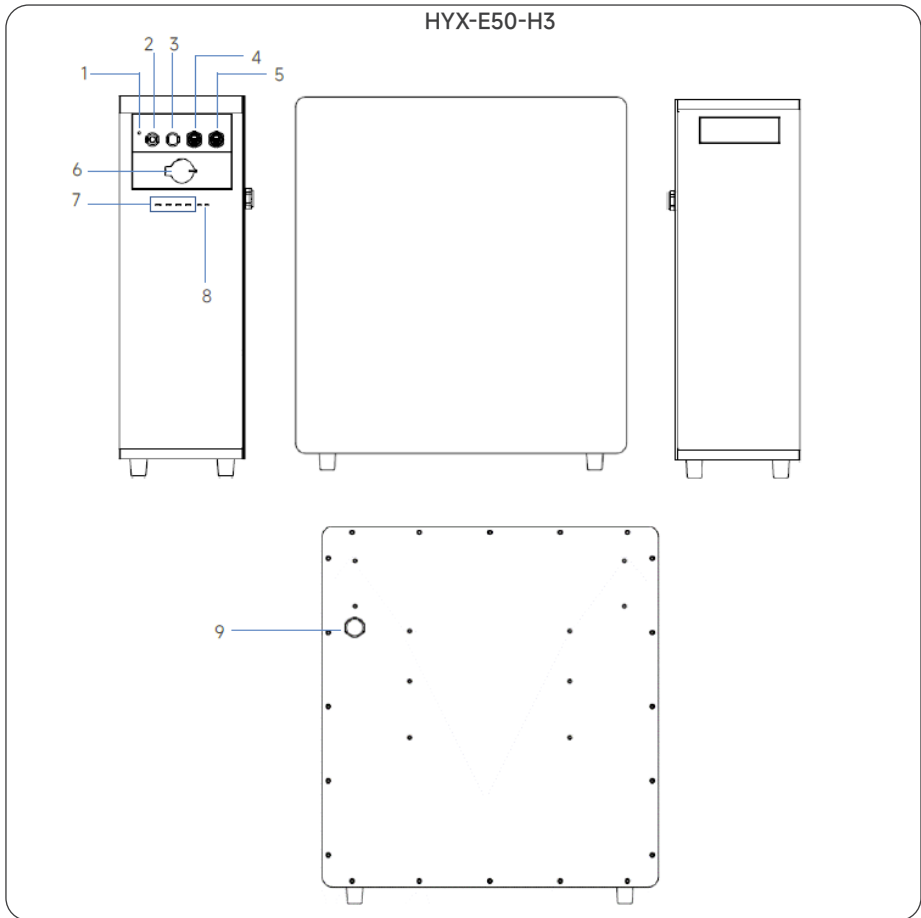

No.	Item	No.	Item
1	Ground Terminal	6	Power Switch
2	High-voltage positive socket	7	BMS SOC LED
3	High-voltage negative socket	8	BMS Status LED
4	COM INV	9	Explosive-proof valve
5	COM Parallel		

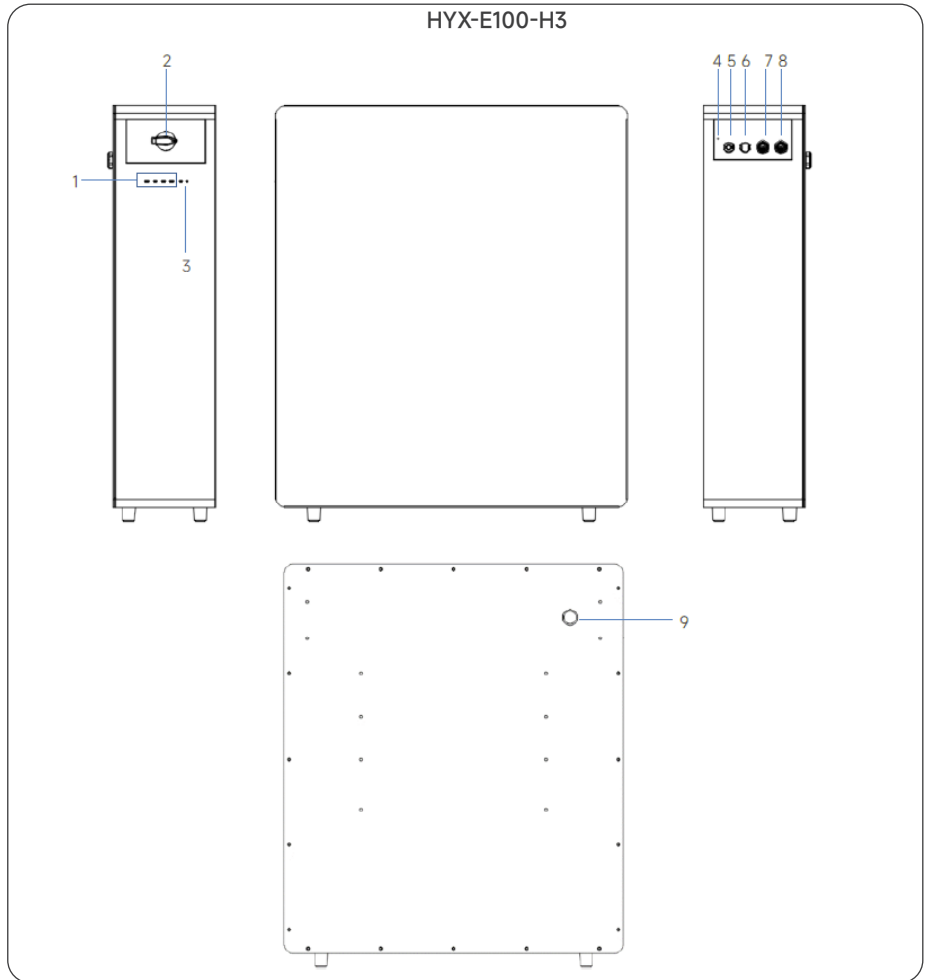

No.	Item	No.	Item
1	BMS SOC LED	6	High-voltage negative socket
2	Power Switch	7	COM INV
3	BMS Status LED	8	COM Parallel
4	Ground Terminal	9	Explosive-proof valve
5	High-voltage positive socket		

5 Mechanical Installation

NOTICE

- The battery is heavy. There is a risk of injury if the battery is not lifted or dropped properly during transportation or during installation or removal.
- Two or more people must lift and transport the inverter and battery.
- When wiring the battery, it must be well protected, one person should wire and one person should supervise and check to prevent the battery short circuit accident.
- The electrical connection must be complete and firm, and the installation position and direction of the CT on the grid side must be correct (the direction of the arrow of the CT faces the grid side), otherwise the current will not be detected; in addition, if you need to realize the backflow prevention, the CT should be installed on the main road of the grid.
- The installer should wear protective equipment.

5.1 Floor-Mounting

Step 1: Secure the ground mounting bracket to the designated position on the back of the battery using M6*12 screws.

Step 2: Move the battery close to the wall and mark the drilling position.

Step 3: Drill a hole at the location shown, the depth of the hole is about 60mm.

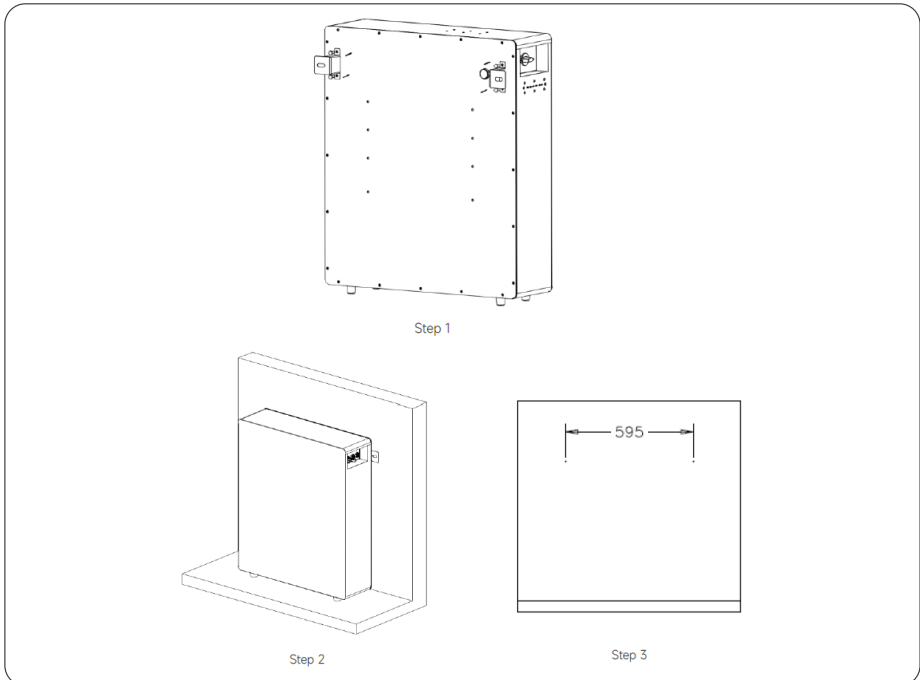

Step 4: Place the expansion tube and secure the battery using the expansion bolt assembly.

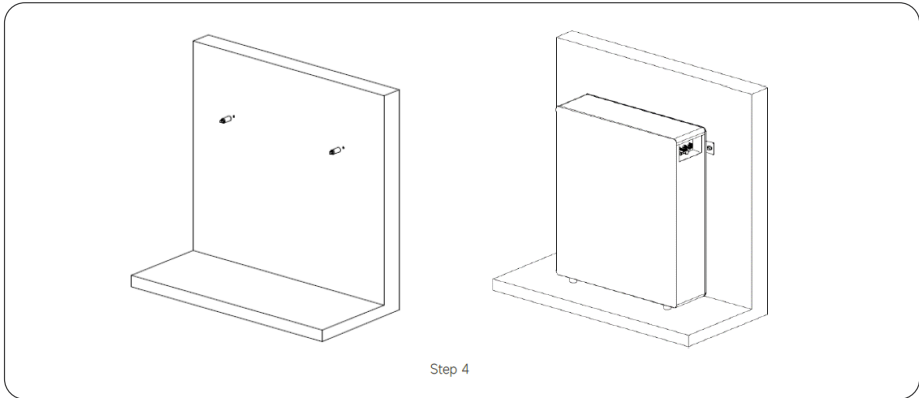

5.2 Wall-Mounting

Step 1: Use 8- M6*12 screws to fix wall mounting bracket on the battery.

Step 2: Place the wall mounting bracket horizontally on the wall, recommend to select the hole position shown in the picture and mark the drilling position.

Step 3: Drill a hole at the location shown, the depth of the hole is about 60mm.

Step 4: Place the expansion tube and install the wall mounting bracket using the expansion bolt assembly.

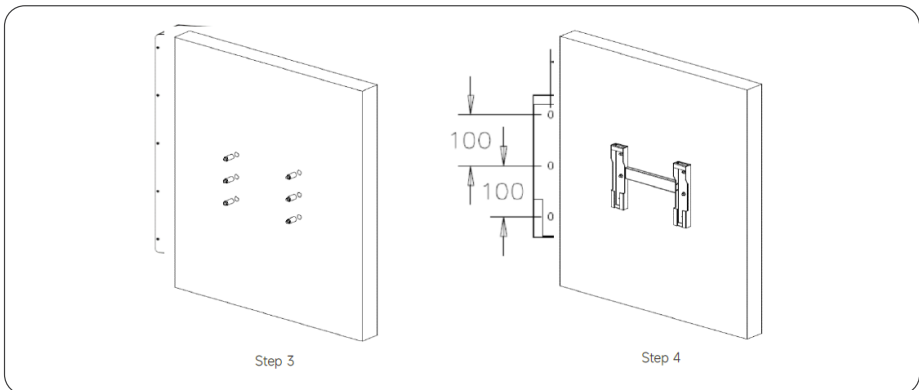

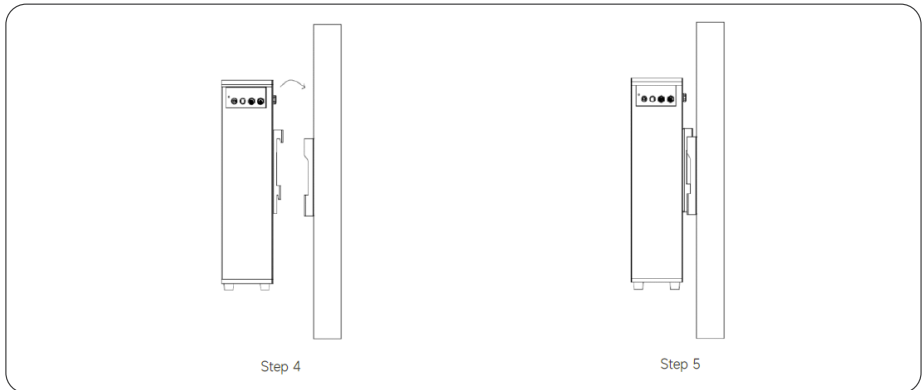

Step 5: Align the buckle of the battery bracket with the holes of wall mounting bracket on the wall, then place the battery from top to bottom.

Step 6: Observe the left and right sides of the bracket to ensure that the holes of the battery bracket and wall mounting bracket on the wall are aligned.

⚠ DANGER

- Before drilling, please make sure to avoid the pre-buried utility lines in the wall to avoid danger.
- To prevent dust from entering human respiratory tract or eyes when punching holes, personnel should wear appropriate protective gear.

6 Electrical Connection

6.1 Grounding Connection

NOTICE

- The cross-sectional area of the secondary grounding cable must be the same as the cross-sectional area of the PE core in the AC cable.
- The secondary grounding cable and terminal block are to be prepared by the customer.

Step 1: Make the cable and crimp the terminal block.

Step 2: Remove the screws from the grounding terminal and use a screwdriver to secure the cable.

Step 3: Apply silicone or paint to the grounding terminal to improve its corrosion resistance.

Step 4: Use an M4 hex socket electric tool (or a manual M4 hex socket wrench) to secure the grounding wire harness to the grounding position on the base with two M4 hex flange nuts.

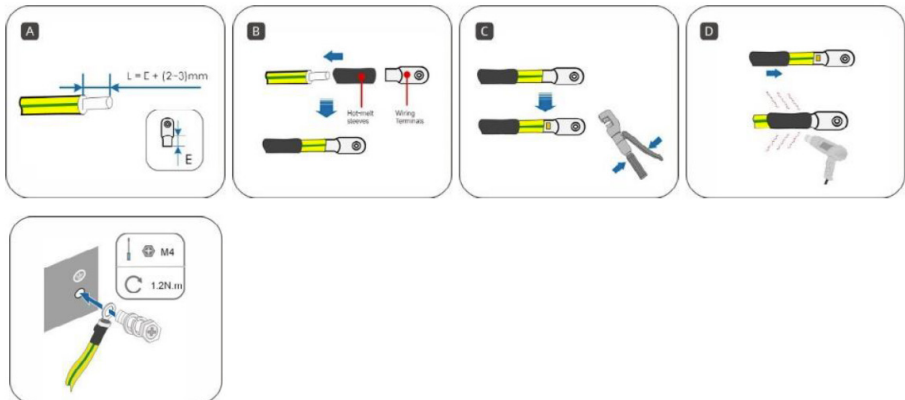

6.2 Battery Connection

Step 1: Strip off the insulation layer of all DC cables by about 7mm.

Step 2: Use crimping pliers to bundle the cable ends at the wiring terminals.

Step 3: Pass the cable through the cable gland, insert the insulating sleeve and fasten it. Gently pull the cable to ensure that it is connected and fastened. Use a force of 2.5-3N·m to tighten the gland and insulating sleeve.

Step 4: Use a multi-meter to check and confirm that the polarity of the photovoltaic string connecting cable is correct.

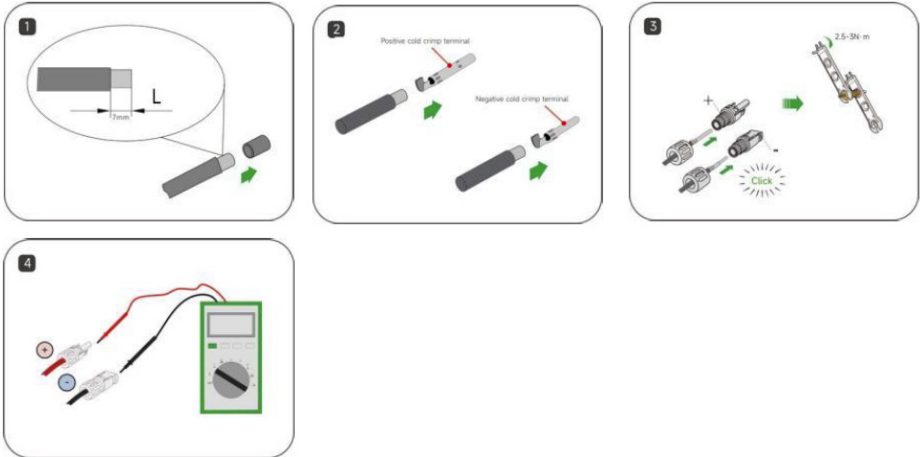

Step 5: Connect the inverter's negative quick plug to the BAT- socket of the battery. Connect the inverter's positive quick plug to the BAT+ socket of the battery.

Step 6: Connect the inverter's communication cable to the COM port of Battery (Only parallel needs two communication cable).

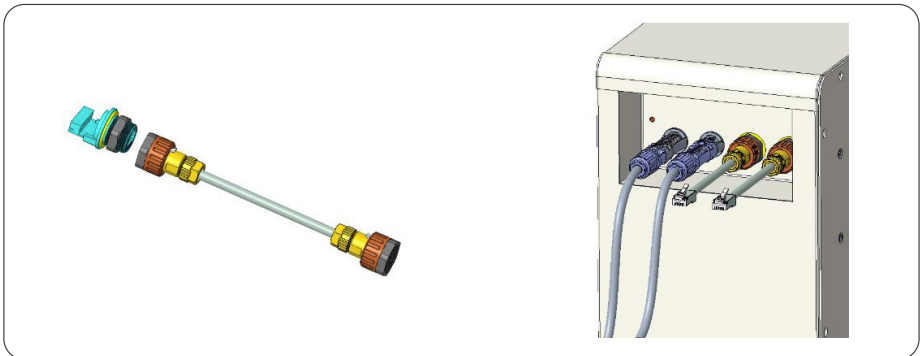

6.3 Parallel Connection

Parallel communication procedure:

Step 1: Prepare Parallel Adapter Cable*2, Communication Cable.

Step 2: Loosen the rear cap of the waterproof connector on the communication cable and remove the connector. (If the communication cable does not include a waterproof connector, skip this step.)

Step 3: Disassemble the waterproof RJ45 connector: Subject, Boundary line body, Spigot, Blind nut; And attach all the above parts to the communication cable.

Step 4: Connect the communication cable and the Parallel Adapter Cable—Parallel Communication Cable.

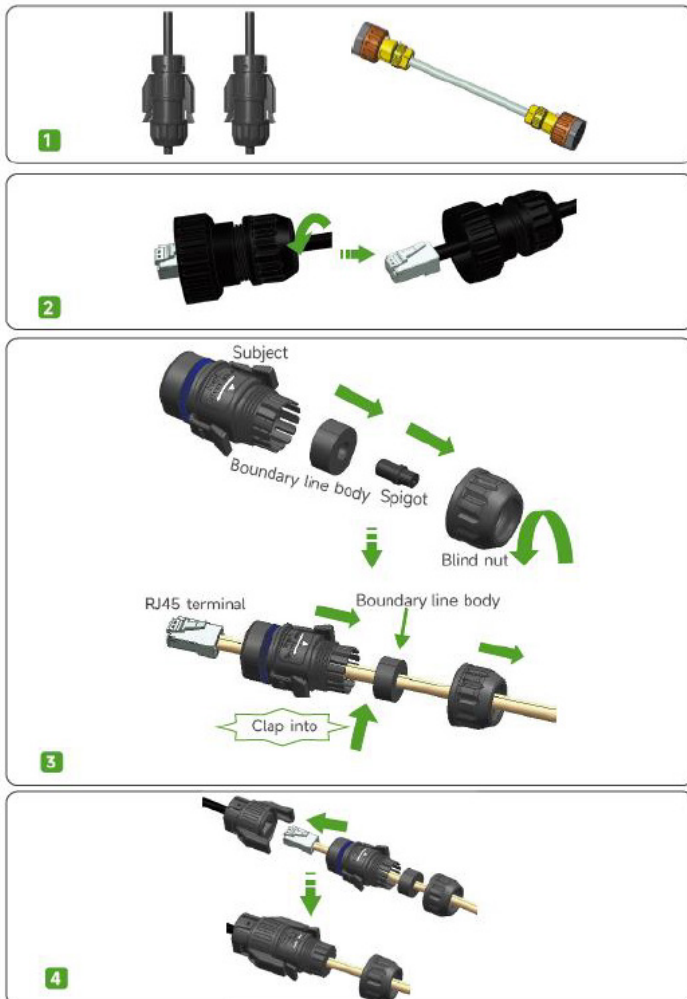

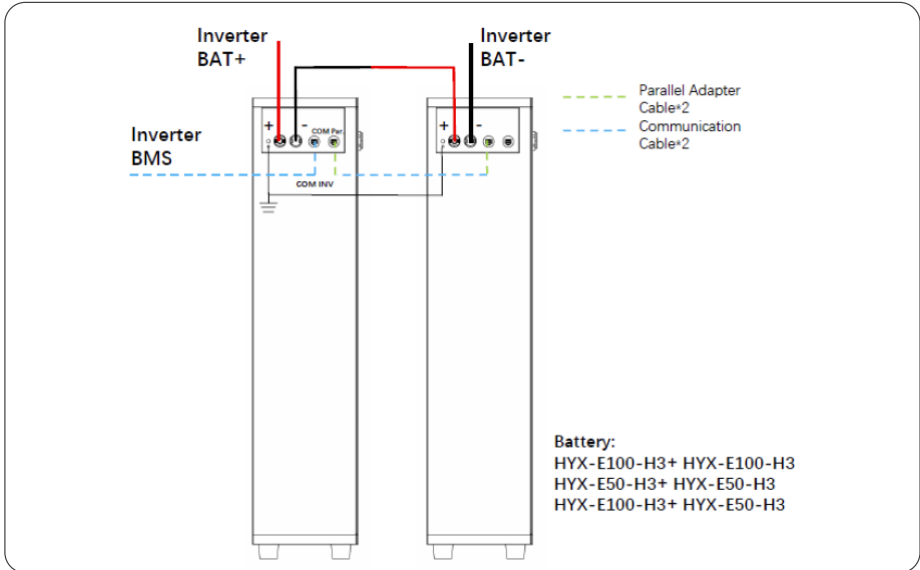
Connection for two batteries:

- Step 1:** Connect the COM1 port of the first battery (Master) to the BMS port of the inverter using the communication cable.
- Step 2:** Use communication cable and two parallel adapter cables to connect the COM port between two batteries.
- Step 3:** Connect the Ground Cable from the ground terminal of two batteries.
- Step 4:** Use power cable to connect the inverter's BAT+ port to the first battery "+" port; Use power cable to connect the inverter's BAT- port to the second battery "-" port; Use power cable to connect two batteries: "+" connect to "-" .
- Step 5:** After all connections are made, power on the subordinate unit first, then the main unit.

6.4 Electrical and Communication Interfaces

6.4.1 Communication Interface (COM INV-BAT)

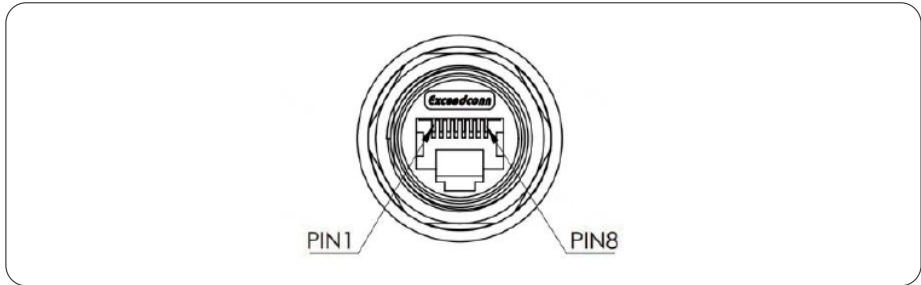

Pin	Item	Function	Connector
1	12V_BDU_COM	Backup power supply	RJ45
2	GND_BDU_COM	Backup power supply	RJ45
3	Encode(+)	Positive input for encoding	RJ45
4	CAN1H	Communication with inverters	RJ45
5	CAN1L	Communication with inverters	RJ45
6	Encode(-)	Negative input for encoding	RJ45
7	CAN2H	Communication with battery	RJ45
8	CAN2L	Communication with battery	RJ45

6.4.2 Communication Interface (COM Par BAT-BAT)

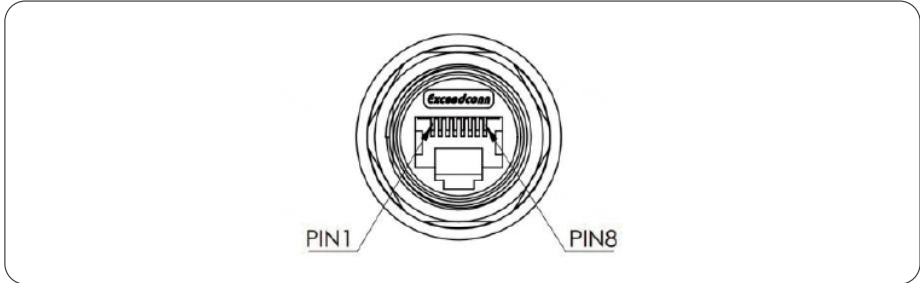

Pin	Item	Function	Connector
1	RS485A	For debugging use	RJ45
2	RS485B	For debugging use	RJ45
3	Encode(+)	Positive input for encoding	RJ45
4	/	/	RJ45
5	/	/	RJ45
6	Encode(-)	Negative input for encoding	RJ45
7	CAN2H	Communication with battery	RJ45
8	CAN2L	Communication with battery	RJ45

6.4.3 Power Button

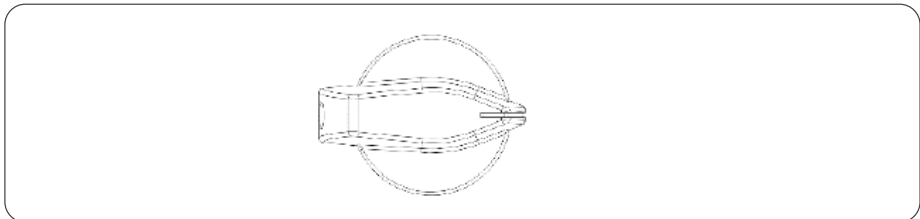

Button	Function
Power	Battery power switch

6.4.4 Power Interface

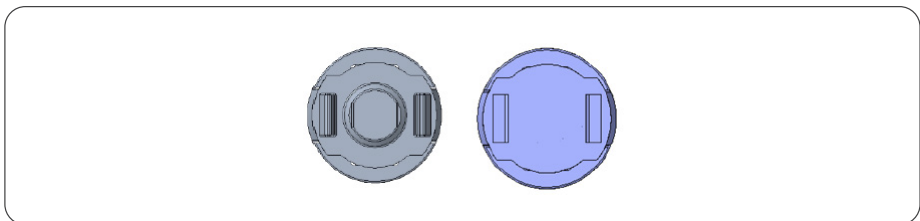

Pin	Item	Function	Remarks	Connector
1	BAT+	Battery output positive	Connecting the inverter	Quick plug
2	BAT-	battery output negative	Connecting the inverter	Quick plug

7 LED Indicator

7.1 LED Display and System Status



Pin	Item
1	SOC Green
2	WORK Blue
3	ALARM Red

System Status	WORK	ALARM	SOC
	●	●	● ● ● ●
Shutdown	Off	Off	Off
Idle state	On 0.5s, off 1.5s	Off	According to the power display
Normal operation	On	Off	According to the power display
First level alarm	According to the system status	On 0.5s, off 0.5s	According to the power display
Second level alarm	According to the system status	On 0.5s, off 1.5s	According to the power display
Third level alarm	According to the system status	On	According to the power display

According to the system status:

Charging Mode: The RUN indicator remains lit if the inverter input current exceeds 1A, otherwise it flashes.

Discharging Mode: The RUN indicator remains lit if the battery input current exceeds 1A, otherwise it flashes.

7.2 SOC Indicators & Battery Capacity

Status	Charging				Discharging			
Capacity indicator	●	●	●	●	●	●	●	●
SOC<25%	On 0.5s, OFF 1.5s	Off	Off	Off	On	Off	Off	Off
25% ≤ SOC<50%	On	On 0.5s, off 1.5s	Off	Off	On	On	Off	Off
50% ≤ SOC<75%	On	On	On 0.5s, off 1.5s	Off	On	On	On	Off
75% ≤ SOC<90%	On	On	On	On 0.5s, off 1.5s	On	On	On	On
90% ≤ SOC<100%	On							
Operation indicator	On							

8 System Commissioning

8.1 System Startup

Turn on the switch, then system will startup.

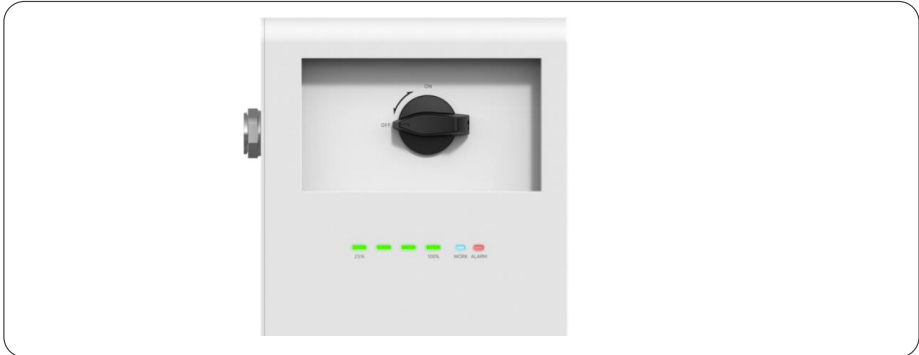

8.2 System Shutdown

Turn off the switch, then the system will shutdown.

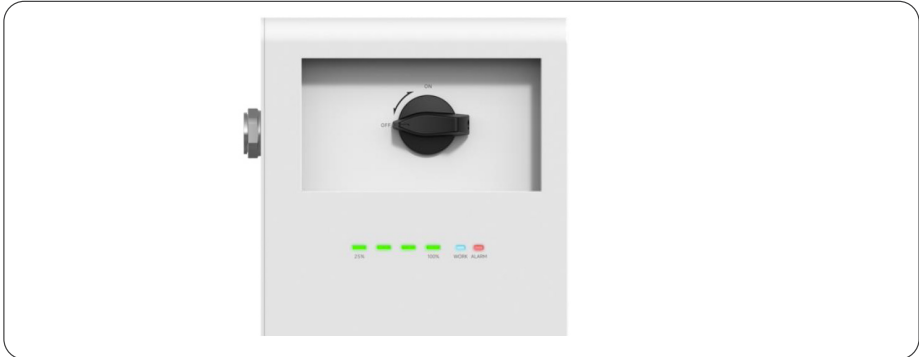

9 Online monitoring

All the battery data is uploaded to the inverter, and the monitoring is uploaded from the inverter side.

10 Maintenance and Troubleshooting

10.1 Routine Maintenance

If the energy storage system is not used for more than three months, it is necessary to charge the energy storage battery to a full charge to avoid over-discharge due to self-consumption of the system.

The battery has a discharge depth of 90%, i.e. the system stops discharging when 10% of the power SOC remains. It is recommended to charge in time.

Product cleaning:

Step 1: First, gently wipe the surface with a soft microfiber cloth to remove dust or debris.

Step 2: Moisten the cloth with water (neutral detergent can also be added) and wring out excess water.

Step 3: Wipe away any debris or dirt.

Step 4: Finally, wipe off all water from the surface with a dry microfiber cloth.

CAUTION

- The cleaning process should be carried out away from electrical connections to prevent water from getting inside the product housing, connection ports, etc.
- Do not wipe the product with reagents other than water (H₂O).

10.2 Troubleshooting

10.2.1 General Troubleshooting

Battery communication failure:

- Failure analysis: CAN communication or 485 communication failure.
- Solution: Check if the communication line is in good contact.

Battery over-undervoltage fault:

- Failure analysis: Voltage range is not compatible with the battery and the battery energy is insufficient.
- Solution: Check the battery voltage, PV or whether it will be charged automatically when there is grid.

Overload fault:

- Failure analysis: The load is too large.
- Solution: Check whether the load exceeds the machine power, all down and then part of the load up.

Output short circuit fault:

- Failure analysis: There is a short circuit working condition on the load side.
- Solution: All power down, after the power indicator goes off, check whether the load is short-circuited, and then power up after troubleshooting.

10.2.2 Alarm Description

The following alarms are recoverable alarms, please refer to the following table to process and resume operation.



Fault name	Action	Recovery conditions
Battery discharge overcurrent	Prohibition of discharge/high voltage relay disconnection	<ul style="list-style-type: none"> • Turn off part of the load. • Reboot the device.
Battery charging overcurrent	Prohibition of charge/high voltage relay disconnection	<ul style="list-style-type: none"> • Restart the device. • Contact HYXiPOWER after-sales staff to solve.
Battery charging over-voltage	Prohibition of charge/ high voltage relay disconnection	<ul style="list-style-type: none"> • Restart the device. • Contact HYXiPOWER after-sales staff to solve the problem.
Battery discharge undervoltage	Prohibition of discharge/high voltage relay disconnection	<ul style="list-style-type: none"> • Restart the device. • Contact HYXiPOWER after-sales staff to solve the problem.
Battery discharge high temperature	Prohibition of discharge/high voltage relay disconnection	<ul style="list-style-type: none"> • Turn off the load of the equipment, and leave it until the battery temperature is less than 40°C . • Contact HYXiPOWER after-sales personnel to solve.

Fault name	Action	Recovery conditions
Battery charging high temperature	Prohibition of charge/high voltage relay disconnection	<ul style="list-style-type: none"> • Leave the battery temperature less than 40°C . • Contact HYXiPOWER after-sales personnel to solve.
Battery discharging low temperature	Prohibition of discharge/high voltage relay disconnection	<ul style="list-style-type: none"> • Leave to wait for the battery temperature is greater than 2°C . • Contact HYXiPOWER after-sales personnel to solve.
Excessive battery temperature difference	Prohibition of discharge and charge/high voltage relay disconnection	<ul style="list-style-type: none"> • Leave the battery temperature difference less than 4°C . • Contact HYXiPOWER after-sales personnel to solve.
Loss of communication with PCS	High Voltage Relay Disconnection	<ul style="list-style-type: none"> • Check the connection between BDU and PCS harness. • Contact HYXiPOWER after-sales staff to solve the problem.
Tandem cascade communication lost	High Voltage Relay Disconnection	Contact HYXiPOWER after-sales personnel to solve.
Battery pack communication lost	High Voltage Relay Disconnection	<ul style="list-style-type: none"> • Check the connection between BDU and battery pack harness. • Contact HYXiPOWER after-sales staff to solve the problem.
BDU overtemperature	Prohibition of charging and discharging/high voltage relay disconnection	<ul style="list-style-type: none"> • Leave to BDU temperature less than 70°C . • Contact HYXiPOWER after-sales personnel to solve.
Current collection sensor overtemperature	Prohibition of charging and discharging / high voltage relay disconnection	<ul style="list-style-type: none"> • Leave the sensor temperature less than 70°C . • Contact HYXiPOWER after-sales staff to solve.
BDU main positive relay failure	Prohibit high voltage/Prohibit charging and discharging/ Disconnecting high voltage relay	Contact HYXiPOWER after-sales personnel to solve.
BDU main negative relay failure	Prohibit high voltage/Prohibit charging and discharging/ Disconnecting high voltage relay	Contact HYXiPOWER after-sales personnel to solve.
Pre-charge fault	Prohibit high voltage	<ul style="list-style-type: none"> • Restart the device. • Contact HYXiPOWER after-sales staff to solve the problem.
BMS self-test fault	Prohibit high voltage	<ul style="list-style-type: none"> • Restart the device. • Contact HYXiPOWER after-sales staff to solve the problem.

Fault name	Action	Recovery conditions
Battery temperature detection sensor failure	Prohibit high voltage/Prohibit charging and discharging/ Disconnecting high voltage relay	<ul style="list-style-type: none"> • Restart the device. • Contact HYXiPOWER after-sales staff to solve the problem.
Cell voltage sampling line failure	Prohibit high voltage/Prohibit charging and discharging/ Disconnecting high voltage relay	<ul style="list-style-type: none"> • Restart the device. • Contact HYXiPOWER after-sales staff to solve the problem.
Low insulation resistance of BDU	Prohibit high voltage	<ul style="list-style-type: none"> • Restart the device. • Contact HYXiPOWER after-sales staff to solve the problem.

11 Appendix

11.1 Technical Parameter

Battery System	HYX-E50-H3	HYX-E100-H3
Appearance		
Nominal Battery Energy [kWh]	5.12	10.4
Usable Capacity † [kWh]	4.6	9.36
Nominal Voltage [V]	102.4	208
Working Voltage [V]	86.4 ~ 115.2	175.5 ~ 234
Cell Type	LiFePO4	
Nominal Charging/Discharging Current [A]	25	
Max. Charge/Discharge Current [A]	30	
Peak Charge/Discharge Current [A]	60 A (10S, 25°C)	
Dimensions (W x D x H) [mm]	535*498*185.7	640*730*185
Net Weight [kg]	56	105
SOC Indicator	4*LED (25%, 50%, 75%, 100%)	
State Indicator	2*LED (work, alarm)	
Working Temperature	Charge: 0 to +55 °C ; Discharge: -20 to +55 °C	
Ingress Protection Rating	IP65	
Working Humidity [RH]	5 ~ 95%	
Calendar Life	> 6,000 (70%EOL)	
Operating Altitude [m]	≤ 3,000	
Communication	CAN, RS485	
Alarms	Over charge / Over discharge / Over current / Over temperature / Short Circuit	

*1: Test conditions: 100% depth of discharge, 0.2C rate charge & discharge at 25°C , at the beginning of service life.

11.2 Contact Information

If you have any questions about this product, please contact us.

In order to provide you with faster and better after-sales service, we need your assistance in providing the following information.

- Equipment model : _____
- Serial number of the equipment: _____
- Fault code / name: _____
- A brief description of the fault phenomenon: _____

Version: UM_HYX-H(50-100)-H3_V1.6-202604_EN

The manual is subject to change without notice while the product is being improved.



Zhejiang Hyxi Technology Co., Ltd.

Building 1, No. 57 Jiang'er Road, Changhe Street, Binjiang District,
Hangzhou, Zhejiang Province, China

www.hyxipower.com

support@hyxipower.com