

HYBRID INVERTER

HYX-H3K-HS / HYX-H3K6-HS / HYX-H4K-HS /
HYX-H4K6-HS / HYX-H5K-HS / HYX-H6K-HS /
HYX-H8K-HS

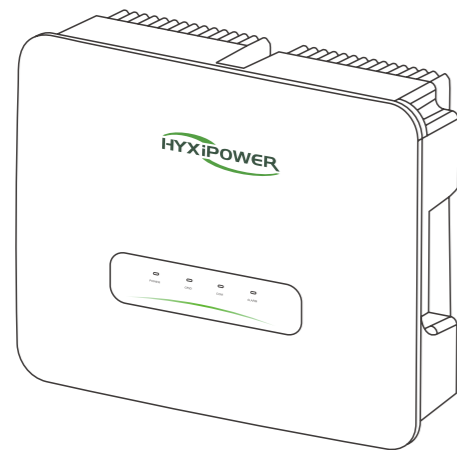

1 Packing list

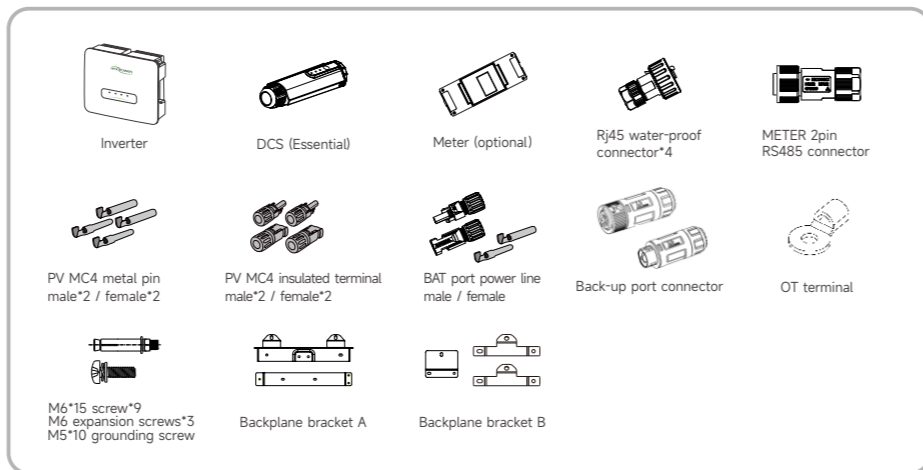

NOTES

DCS need to order separately;
RJ45 water-proof connector*4: 2 for BDU-INV, 1 for DRM, 1 for COM.2;

2 Installation Preparation

2.1 Installation Environment Requirements

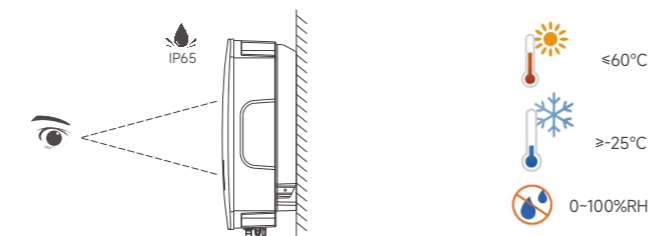

2.2 Installation Space Requirements

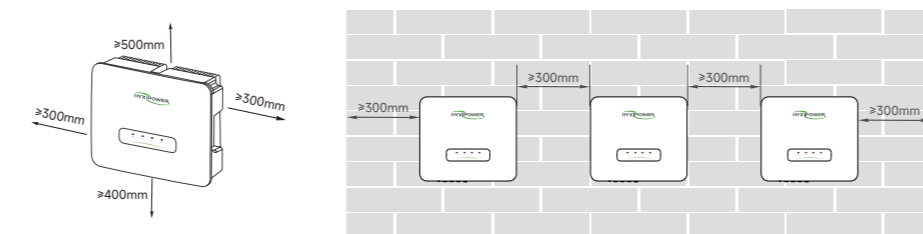

3 Installing the Inverter

3.1 Hanging Plate Size

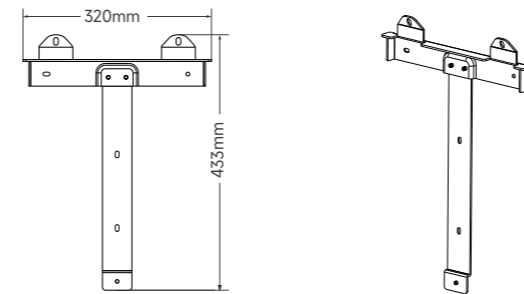

3.2 Installation Steps

- Step 1: Place the wall plate horizontally on the wall.
- Step 2: Drill a hole about 70mm.
- Step 3: Install the wall plate using the expansion bolt assembly.
- Step 4: Secure the mounting plate with M6 screws.
- Step 5: Hang the mounting lugs and tighten them with M6 screws and finally lock them.

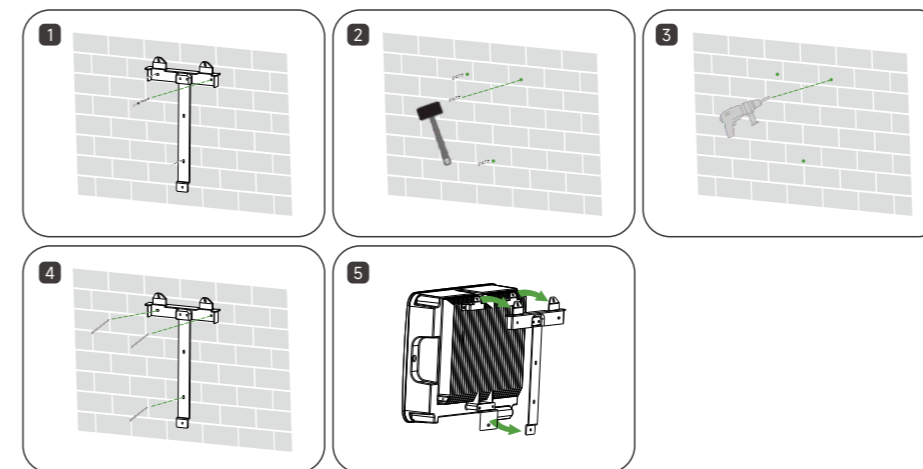

4 Electrical Connection

4.1 Grounding Procedure

The cross-sectional area of the secondary grounding cable must be the same as the cross-sectional area of the PE core in the AC cable.

The secondary grounding cable and terminal block are to be prepared by the customer.

- Step 1: Make the cable and crimp the terminal block.
- Step 2: Remove the screws from the grounding terminal and use a screwdriver to secure the cable.
- Step 3: Apply silicone or paint to the grounding terminal to improve its corrosion resistance.

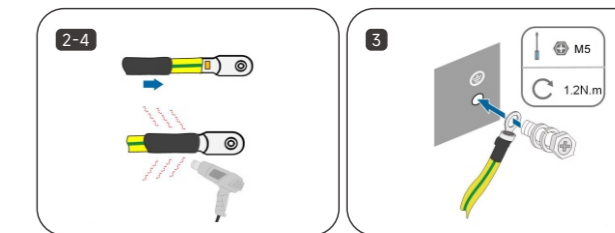
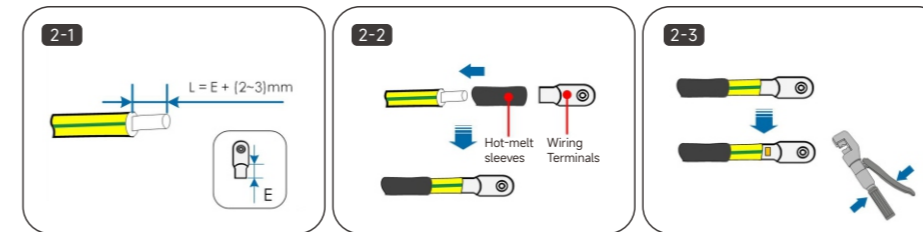

4.2 PV Side Connection

PV cable need prepared by installers (Conductor cross-section:4-6mm²).

- Step 1: Keep the switch on the inverter in the off state.
- Step 2: Strip all DC cable insulation by approximately 7mm. Use crimping pliers to bundle the cable ends at the terminals.
- Step 3: Insert the cable through the cable sealing sleeve, insert it into the insulating sleeve and fasten it, and pull the cable gently to make sure it is tightly connected. Use 2.5-3N·m force to tighten the sealing sleeve and insulation sleeve.
- Step 4: Insert the assembled cold crimp terminal into PV connector until a click is heard.
- Step 5: Use a multimeter to check the correct polarity of the PV string connection cable.
- Step 6: Connect the PV connector to the appropriate terminal until a click is heard.

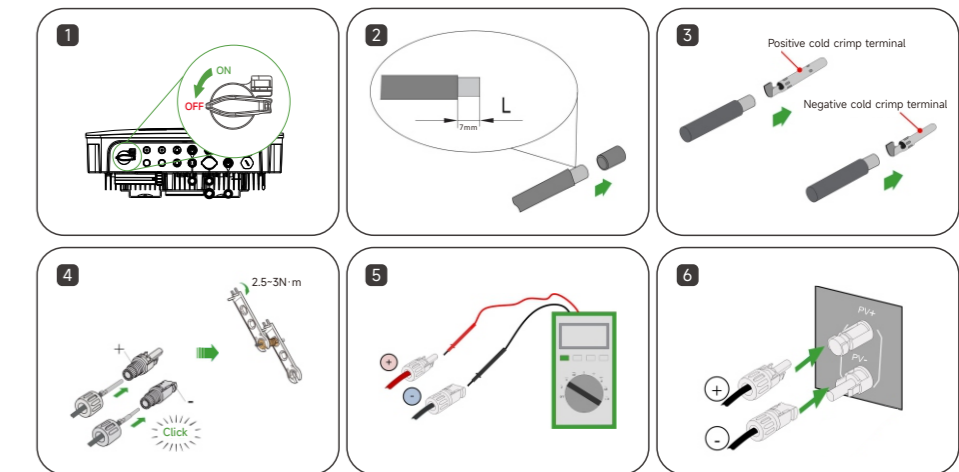

4.3 AC and BACK-UP Side Connection

AC and Back-up port wiring steps are same.

Power line cable need prepared by installers (Conductor cross-section:6-8mm²).

- Step 1: Disassembling connector.
- Step 2: Strip off a certain length of the protective layer and insulation as shown in the diagram.
- Step 3: Adjust the 3 hexagonal screws loosely, do not unscrew the screws completely. Insert the 3 cores (of step 2) into the corresponding screw holes.
- Step 4: Lock all 3 cores (of step 2) with 3 hexagonal screws.
- Step 5: Assembling connector. Connect the AC connector to the appropriate terminal until a click is heard.

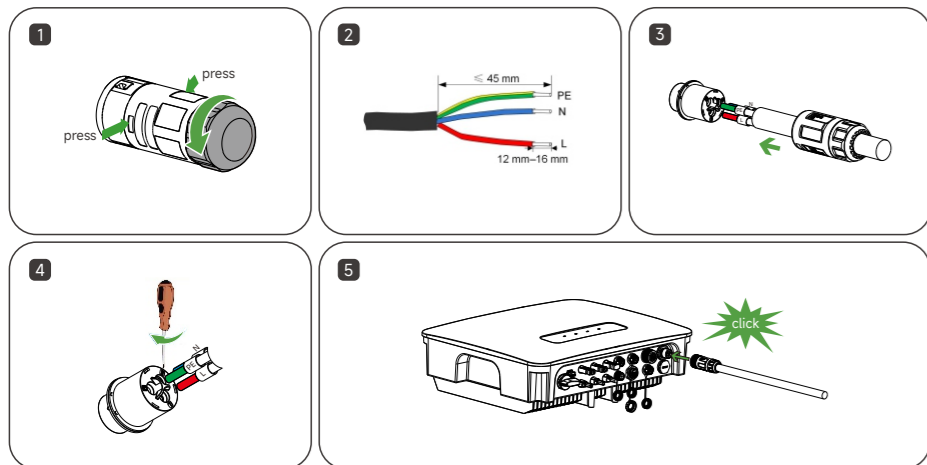

4.4 BDU Side Connection

INV-BDU power line(INV side) are same with 4.2 PV Side Connection.

Connector come standard with the inverter.

INV-BDU power line(BDU side) please refer to BDU manual. Connector come standard with BDU.

Power line cable need prepared by installers (Conductor cross-section:6mm²).

4.5 BAT Power Cable Connection

Two 3m BAT power cable will be included in BDU package as standard. These two power cable already been made in BAT side. INV side not been made in order to facilitate casing.

Please refer to the PV connector to make the battery connector ready & connect it to inverter BAT port. Communication cable please connect to BAT CAN port.

NOTES

The battery base (in BDU package) must be installed, otherwise the battery cannot form a circuit.

5 Communication Connection

5.1 Inverter & BDU Communication Connection Steps

One 3m BAT communication cable will be included in BDU package as standard. Please connect this 3m communication cable to Inverter BMS port and BDU .

5.2 Meter Communication Connection

- Step 1: Place black seal ring on the green Locker.
- Step 2: Put red seal ring into the bottle of body inside.
- Step 3: Wire striping.
- Step 4: Pass all parts through the wire in the following order.
- Step 5: Crimp the 2pin copper core on the green locker and tighten it.
- Step 6: Screw all parts together and connect the water-proof 2pin connector to inverter meter port.

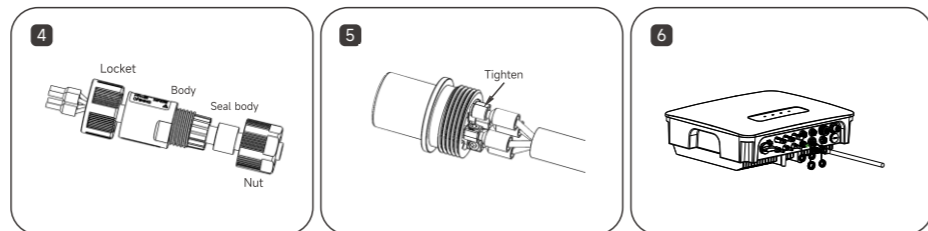
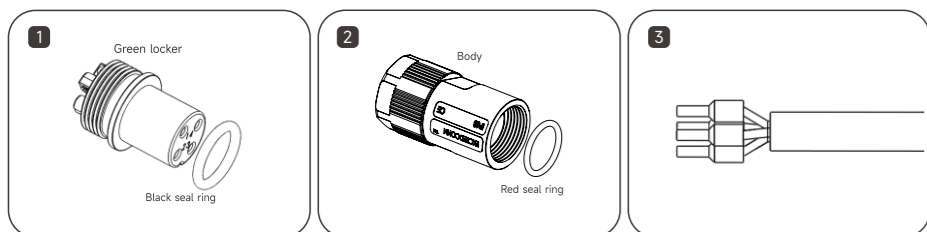

Inverter METER port	1	2	3 (Reserved dry contact)	4 (Reserved dry contact)
Smart Meter Side	485A	485B	/	/

INV-meter connection meter side, INV and meter connected by RS485 2pin cable.

Please refer to the following for more details please refer to the manual in the meter package.

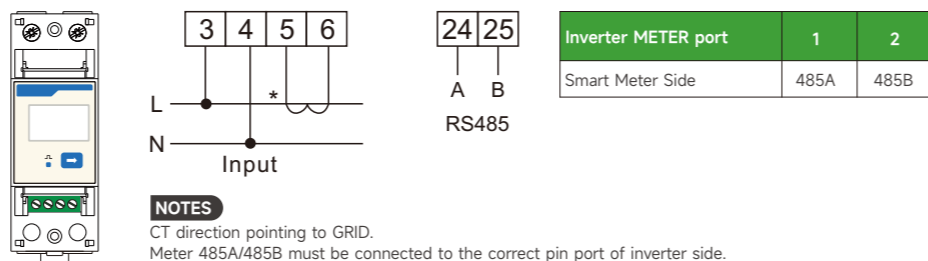

5.3 DCS Installation (WIFI module)

- Step 1: Remove the waterproof cover at the communication interface of the inverter.
- Step 2: Insert DCS into the corresponding communication terminal at the bottom of the inverter and tighten it to ensure it is secure.

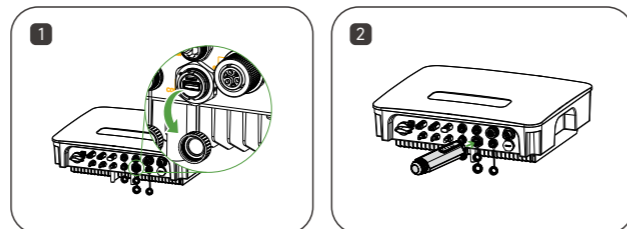

5.4 DCS Installation (4G module)

- Step 1: Remove the protective cover of DCS and insert the SIM card.
- Step 2: Install the waterproof cover of DCS.
- Step 3: Remove the waterproof cover at the communication interface of the inverter.
- Step 4: Insert DCS into the corresponding communication terminal at the bottom of the inverter and tighten it to ensure it is secure.

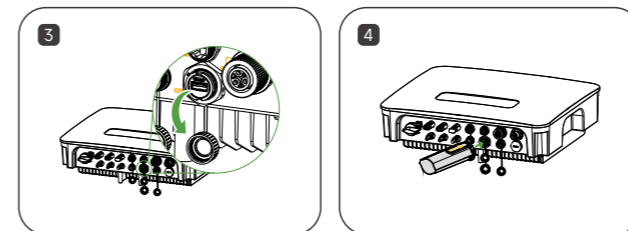
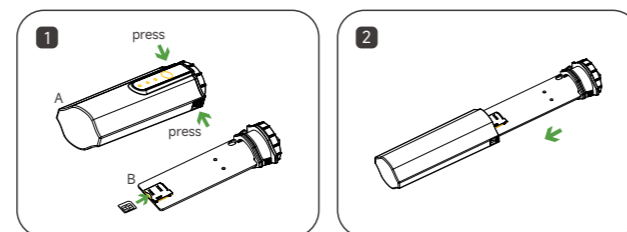

5.5 DCS Installation (WLAN module)

- Step 1: Replace the bottom plug of DCS with the WLAN plug.
- Step 2: Insert the network cable connector into the network junction.
- Step 3: Remove the waterproof cover at the communication interface of the inverter.
- Step 4: Insert DCS into the corresponding communication terminal at the bottom of the inverter and tighten it to ensure it is secure.

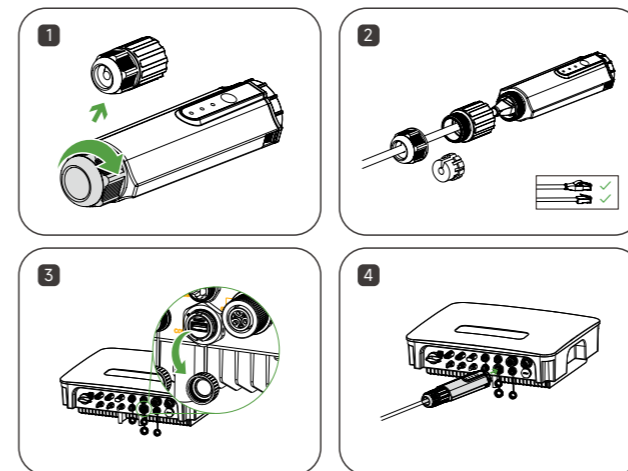

6 LED Indicator

6.1 LED Indicator Status Description

One 3m BAT communication cable will be included in BDU package as standard. Please connect this 3m communication cable to Inverter BMS port and BDU.

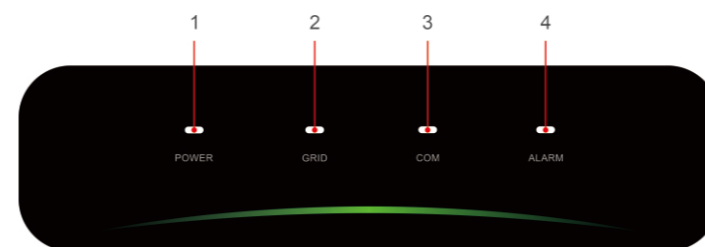

No.	Indicator	Status	Description
1	POWER	ON	Inverter Powered ON
		OFF	Inverter Powered OFF
2	GRID	ON	Grid Normal
		Blink 1	Grid Abnormal
		Blink 2	Grid Disconnected
		OFF	Grid Disconnected

* 1 time flashing, interval 1.5 seconds; 2 times flashing, interval 0.2 seconds.

No.	Indicator	Status	Description
3	COM.	ON	COM. Normal
		Blink 1	Meter COM. Fault
		Blink 2	COM. Fault With BMS
		OFF	Fault Both Meter & BMS
4	ALARM	OFF	Normal
		Blink 1	Inverter Internal Alarm
		Blink 2	Other Alarm

7 System Commissioning

7.1 Installing the App

Method 1
Download the "HYXIPOWER APP" from the app store:

- App Store (IOS)
- Google Play

Method 2
Scan the QR code and download the APP :



App Download

7.2 App Quick Guide

For more information on using the HYXIPOWER APP, please scan the QR code.



App Quick Guide



support@hyxipower.com

Product information is subject to change without notice.
© 2024 Zhejiang Hyxi Technology Co., Ltd. All rights reserved.

6.25118.00001
QL_HYX-HI3-8JK-HS_V1.2-202410_EN