

## 5.2 DCS Installation(4G module)

- Step 1: Remove the protective cover of DCS and insert the SIM card;  
 Step 2: Install the waterproof cover of DCS;  
 Step 3: Remove the waterproof cover at the communication interface of the inverter;  
 Step 4: Insert DCS into the corresponding communication terminal at the bottom of the inverter and tighten it to ensure it is secure.

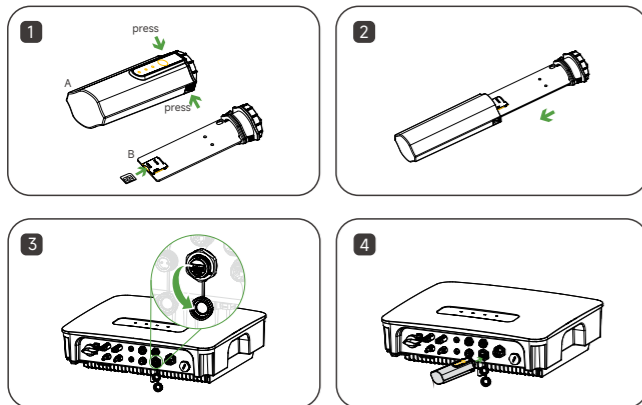

## 5.3 DCS Installation(WLAN module)

- Step 1: Replace the bottom plug of DCS with the WLAN plug.  
 Step 2: Insert the network cable connector into the network junction.  
 Step 3: Remove the waterproof cover at the communication interface of the inverter.  
 Step 4: Insert DCS into the corresponding communication terminal at the bottom of the inverter and tighten it to ensure it is secure.

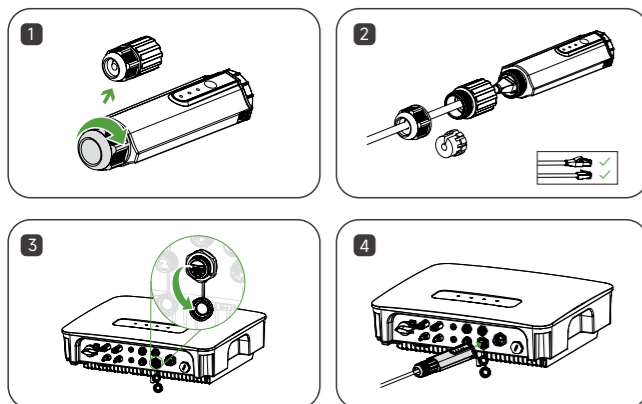

## 5.4 Meter Communication Connection

- Step 1: Place black seal ring on the green Locker.  
 Step 2: Put red seal ring into the bottle of body inside.  
 Step 3: Wire stripping.  
 Step 4: Pass all parts through the wire in the following order.  
 Step 5: Crimp the 2pin copper core on the green locker and tighten it.  
 Step 6: Screw all parts together and connect the water-proof 2pin connector to inverter meter port.

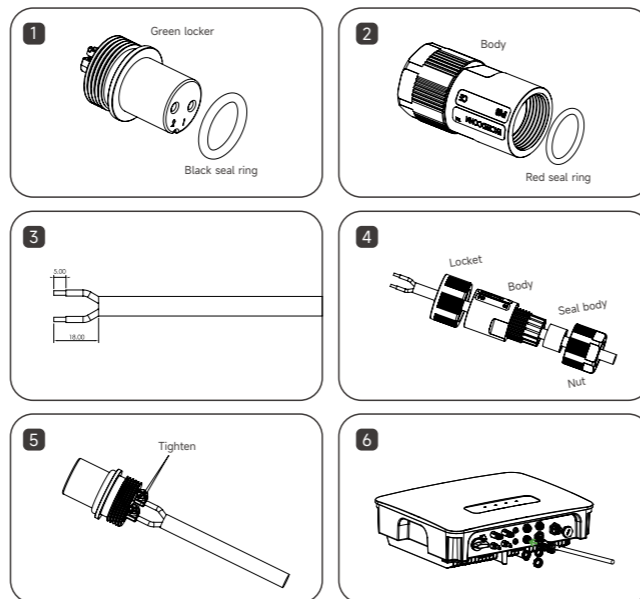

## 6. Power On the System

### 6.1 Pre-Run Checks

1. Turn on the DC switch at the bottom of the inverter.
2. Turn on the AC switch between the solar inverter and the power grid.
3. Turn on the DC switch (if any) between the PV string and the solar inverter.
4. Observe the LED indicators to check the status of the solar inverter.

### 6.2 LED Indicator Status Description

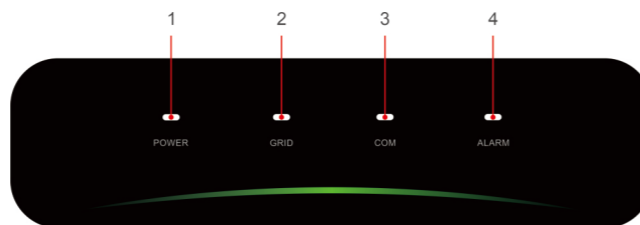

No.	Indicator	Status	Description
1	POWER	ON	Inverter Powered ON
		OFF	Inverter Powered OFF
2	GRID	ON	Grid Normal
		Blink 1	Grid Abnormal
		Blink 2	Grid Disconnected
3	COM.	ON	COM. Normal
		OFF	Meter COM. Fault
4	ALARM	OFF	Normal
		Blink 1	Inverter Internal Alarm
		Blink 2	Other Alarm

\* 1 time flashing, interval 1.5 seconds; 2 times flashing, interval 0.2 seconds.

## 7. System Commissioning

### 7.1 Installing the App

Method 1  
 Download the "HYXIPOWER APP" from the app store:

- App Store (IOS)
- Google Play

Method 2  
 Scan the QR code and download the APP :



App Download

### 7.2 APP Quick Guide

For more information on using the HYXIPOWER APP, please scan the QR code.



App Quick Guide

QUICK  
 INSTALLATION  
 GUIDE



# STRING INVERTER

S8K/10K/12K-T

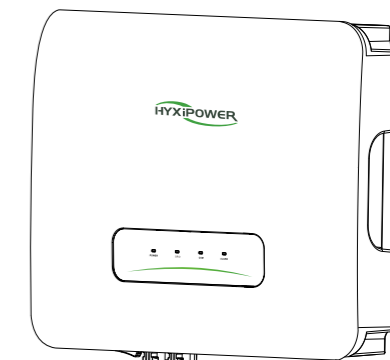

Product information is subject to change without notice.  
 © 2024 Zhejiang Hyxi Technology Co., Ltd. All rights reserved.

6.2.51.18.00048  
 QI-HYXISZK-T\_Global\_EN\_Ver1.0-202401

www.hyxipower.com

## 1. Safety Instructions

### ⚠ DANGER

- Exposure of the PV module to sunlight will generate dangerous voltages.
- Make sure the inverter doesn't have any electrical connections before installation.
- Make sure that all cables are not energized before making electrical connections.
- Do not open the enclosure at any time. Unauthorized opening will void guarantee and warranty claims, and Hyxipower shall not be held liable for any damage caused.

### ⚠ WARNING

- Only qualified personnel can perform the wiring of the PV system.
- Any improper operation during wiring may result in equipment damage or personal injury or death.
- All the warning labels and nameplate on the inverter body must be clearly visible and not be removed, covered or pasted.

### ⚠ CAUTION

- Before installing the equipment, please check whether the goods are complete and whether there is any damage according to the packing list.
- Improper handling of the equipment may result in minor, serious or contusive injuries.
- The wiring process must follow the relevant rules of the local power grid and the relevant safety instructions for PV modules.
- After the inverter has been shut down, there is still a risk of burns. After the inverter has cooled down, it is necessary to wear protective gloves before operating the inverter.

### Symbol Description

Symbol	Description
	Disconnect power for at least 5 minutes before servicing the inverter
	Do not touch the inverter housing while it is in operation
	Only install and operate the inverter with professional personnel
	Do not remove the DC input connector or the AC output connector when the inverter is running
	Read the manual
	CE mark of conformity
	Do not dispose of the inverter as household waste
	High touch current, earth connection essential before connecting supply

## 2. Installation Preparation

### 2.1 Installation Environment Requirements

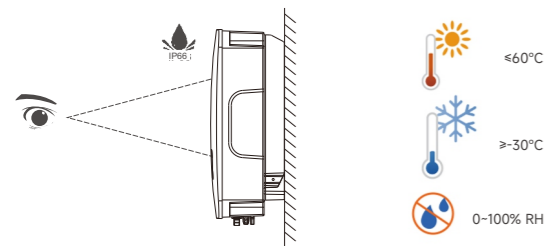

### 2.2 Installation Space Requirements

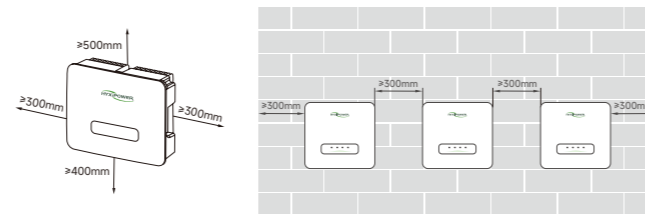

## 3. Installing the Inverter

### 3.1 Hanging Plate Size

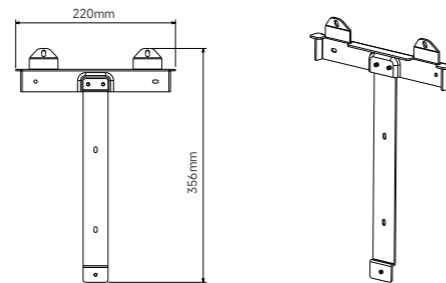

### 3.2 Installation Steps

- Step 1: Place the wall plate horizontally on the wall, recommend to select the hole position shown in the picture and mark the drilling position.
- Step 2: Drill a hole at the location shown, the depth of the hole is about 70mm.
- Step 3: Place the expansion tube and install the wall plate using the expansion bolt assembly.
- Step 4: Secure the mounting plate with M6 screws.
- Step 5: Hang the mounting lugs onto the peg plate and tighten them with M6 screws and finally lock them.

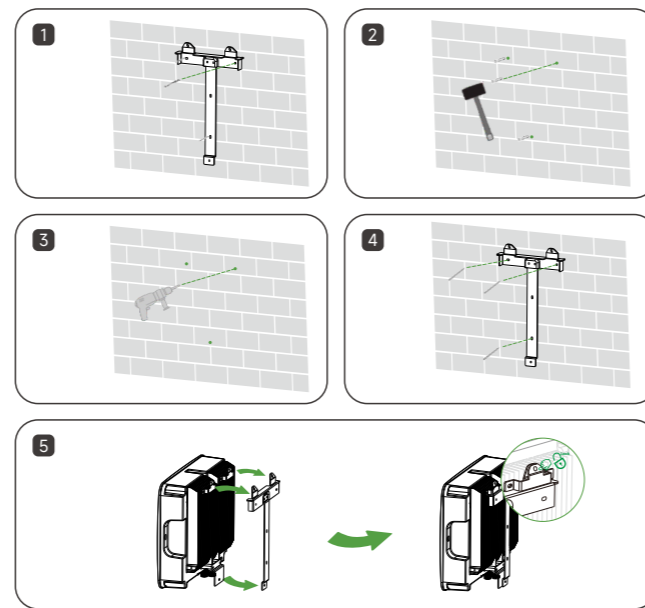

## 4. Electrical Connection

### 4.1 Grounding Procedure

The secondary grounding cable and terminal block are to be prepared by the customer.

- Step 1: Make the cable and crimp the terminal block.
- Step 2: Remove the screws from the grounding terminal and use a screwdriver to secure the cable.

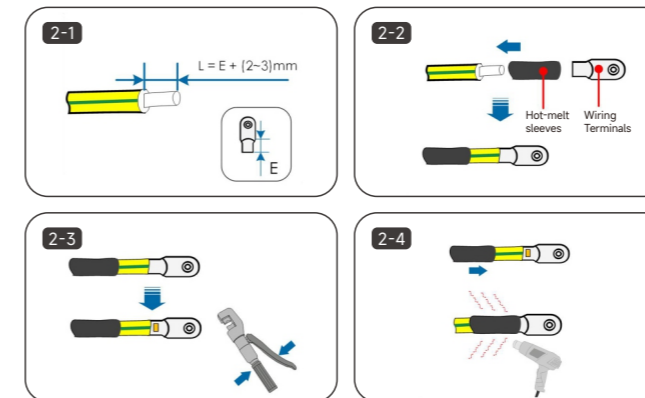

Step 3: Apply silicone or paint to the grounding terminal to improve its corrosion resistance.

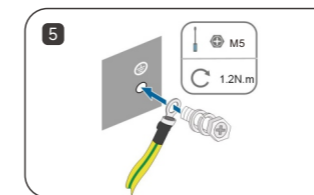

### 4.2 AC Side Connection

- Step 1: Connect the AC output power cable to the AC connector. Stripping requirements.
- Step 2: Unscrew the bottom waterproof fixing bolt of the AC connector.
- Step 3: Thread the cables through the AC terminal blocks one after the other.
- Step 4: Insert the AC terminal blocks into the AC connector and tighten the bottom waterproof fixing bolts.
- Step 5: Plug the AC terminal blocks into the AC output port of the inverter.
- Step 6: Use a screwdriver to remove the AC connector.

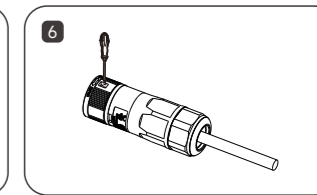
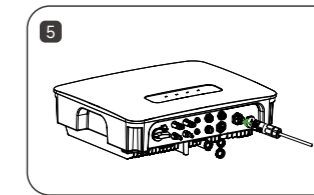
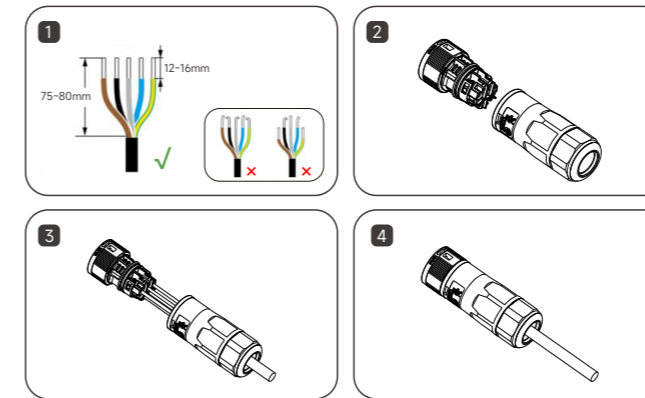

### 4.3 DC Side Connection

- Step 1: Turn the DC switch to "OFF" manually.
- Step 2: Strip off the insulation layer of all DC cables by about 7mm.
- Step 3: Use crimping pliers to bundle the cable ends at the wiring terminals.
- Step 4: Pass the cable through the cable gland, insert the insulating sleeve and fasten it. Use a force of 2.5-3N·m to tighten the gland and insulating sleeve.
- Step 5: Use a multimeter to check and confirm that the polarity of the photovoltaic string connecting cable is correct.
- Step 6: Connect the PV connectors to the corresponding terminals until a click is heard and seal the vacant DC terminals with MC4 waterproof plugs.

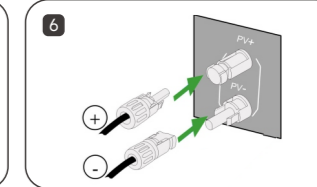
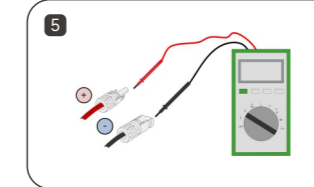
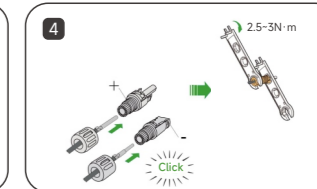
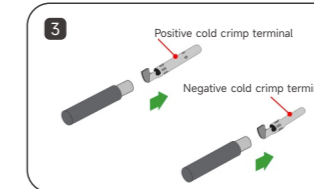
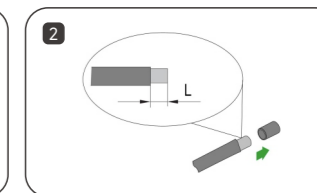
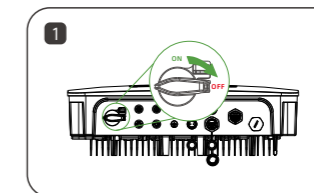

## 5. Communication Connection

### 5.1 DCS Installation(WIFI module)

- Step 1: Remove the waterproof cover at the communication interface of the inverter;
- Step 2: Insert DCS into the corresponding communication terminal at the bottom of the inverter and tighten it to ensure it is secure.

